

Technical Documentation



THREE PHASE INDUCTION MOTORS
WELDED CONSTRUCTION
6000 V 50 Hz 200-6300 kW

VN08EN



We set your ideas in motion. We do not merely manufacture motors, but instead turn the ambitious concepts of our customers into modern, innovative and reliable products, which are unique and point the way to the future. We bring our customers closer to their goals with reliability, creativity and flexibility.

Business Units



Serial Motors



New Businesses



Home Appliances

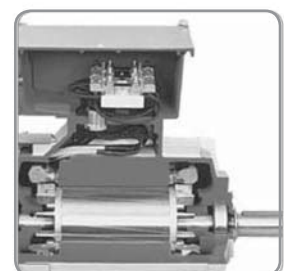

Project Motors

Content

CONTENT	Page
1. INTRODUCTION	2
1.1. Standards and Recommendations	2
1.2. Designation	2
2. MECHANICAL CHARACTERISTICS	3
2.1. Construction	3
2.2. Mounting arrangements	3
2.3. Tolerances of principal dimensions.	3
2.4. Mechanical protection and cooling form	4
2.5. Shaft and bearings	5
2.6. Terminal boxes	7
2.6.1. Stator terminal box.	7
2.6.2. Rotor terminal box	7
2.6.3. Indicator terminal box	7
2.7. Stator core and winding	8
2.8. Rotor core and winding	8
2.8.1. Cage rotor.	8
2.8.2. Slip ring rotor.	8
3. ELECTRICAL CHARACTERISTICS	9
3.1. Voltage and frequency	9
3.2. Rated output	9
3.3. Overload.	9
3.4. Starting torque and current	9
3.5. Speed	10
3.6. Efficiency and power factor.	10
3.7. Noise	10
3.8. Vibrations	10
3.9. Testing	10
3.9.1. Standard testings	10
3.9.2. Additional testings	10
4. FUNDAMENTALS	11
5. ADDITIONAL EQUIPMENT	11
6. SPARE PARTS.	11
7. SPECIAL REQUIREMENTS.	11
8. REQUEST AND ORDERING.	11
9. TECHNICAL DATA	13
10. DIMENSIONAL SKETCHES.	23

I

II

III

IV

V

1. INTRODUCTION

This catalogue includes new line of high voltage induction motors designed in accordance with experience of 30 years in motor production. During this period "SEVER" has delivered several thousands of large motors which are operating in different driving systems in power plants, steel works, pump stations etc. in our and foreign countries.

This line of motor is the third generation of high voltage induction motors based on modern investigations and its construction is modular one i.e. its construction is based on common elements system. The choice of materials, bearings, cooling form and mechanical protection as well as modern design by means of computer enabled the optimal solutions with minimal costs and good electrical and mechanical features.

This catalogue has been designated in the first line to the designers and persons making a choice of the motor for a given application. It is very helpful it contains informations about electrical and mechanical product data. Our desire is to make possible an easy and correct choice of the motor as well as its safe operation.

This catalogue contains:

- High voltage induction motors, shaft heights 355, 400 and 450 mm, power range 200, 6300 kW as it is shown in the Table 1.
- Technical description, electrical product data and dimensional sketches useful for easy and correct choice.

Table:1

Synchronous speed min ⁻¹	Number of poles	Output range, kW	
		IPR 44, IP 23, IPW 24 (air) IF 44 (air-water)	IP 44, IP 54 [air-air]
3000	2	200 ÷ 2800	200 ÷ 2240
1500	4	200 ÷ 6300	200 ÷ 5000
1000	6	200 ÷ 4500	200 ÷ 3550
750	8	200 ÷ 3550	200 ÷ 3150
600	10	200 ÷ 2500	200 ÷ 2240
500	12	200 ÷ 2000	200 ÷ 1600

1.1. Standards and recommendations

Motors described in this catalogue are produced in accordance with standards and IEC recommendations-International Electro-technical Commission:

- IEC 60034-1 Rotating electrical machines (excluding machines for traction vehicles) Part 1: Rating and performance characteristics.
- IEC 60034-2A Rotating electrical machines. Part 2: Methods for determining losses and efficiency from tests (excluding machines for traction vehicles)
- IEC 60034-5 Rotating electrical machines (excluding machines for traction vehicles) Part V: Classification of types of enclosure
- IEC 60034-6 Rotating electrical machines (excluding machines for traction vehicles) Part VI: Classification of methods of cooling
- IEC 60034-7 Rotating electrical machines. Part VII: Symbols for types of construction and mounting arrangements
- IEC 60034-8 Rotating electrical machines. Part VII: Terminal markings and sense of rotation
- IEC 60034-9 Rotating electrical machines. Part IX: Noise Level
- IEC 60034-14 Rotating electrical machines. Part XIV: Vibrations of electrical machine with shaft height 56 and above. Measurement and limits.
- IEC 60071-1 Coordination of insulation. Part 1: Terms, definitions and regulations
- IEC 60072A Dimensions and output ratings for foot-mounted electrical machines with frame numbers 355 to 1000
- IEC 60085 Classification of insulating materials for electrical machines and apparatus on the basis of thermal stability in service.

In the case that there is no IEC Publication, these motors are built in accordance with DIN standards an General requirements for rotating electrical machines VDE 0530. On special request, these motors can be produced and delivered in accordance with another standards and regulations.

1.2. Designation

Every motor is designated with letters and numbers. The letters indicate characteristics of motor, mechanical protection, cooling form and numbers indicate voltage, frame size and number of poles:

K	Cage rotor
O	Open motor
P	Slip ring rotor
W	Open motor cooled by air passing through the filter and protected against splashing water from any direction
R	Enclosed motor with air duct inlet
V	Enclosed motor with heat exchanger "water-air"
Z	Enclosed motor with heat exchanger "air-air"
F	Flange mounted motor
S	Short frame
M	Medium frame
a, b, c, d	Small letters added to capital S and M determine the core length in the stator frame

Numerals

1; 2...	Ordinal number of generation
3; 6; 10.	Rated voltage
355; 400; 450; ...	Shaft height H in mm

Symbols

P_N	Rated output
M_N	Rated torque
n	Rated speed
U_N	Rated voltage
I_N	Rated current
η	Efficiency
$\cos\phi$	Power factor
U_{20}	Locked rotor voltage
I_{2N}	Rated rotor current
I_p	Starting current
M_p	Starting torque
M_{PR}	Pull out torque
I_m	Moment of inertia of a motor
I_d	Allowed additional Moment of inertia
M	Motor mass
A	Drive end
B	Non-drive end
2p	Number of poles

Example:

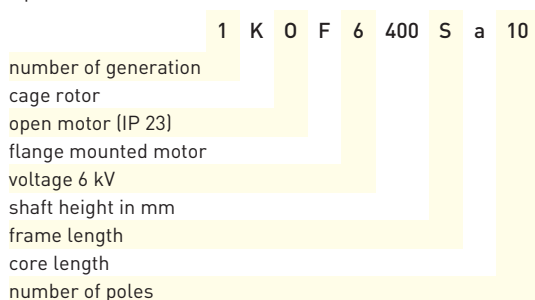

2. MECHANICAL CHARACTERISTICS

2.1. Construction

Construction of these motors are welded type. The frame and endshields are welded from different steel sheet elements. The inside lattice construction and outside enclosure gives very high stability to the frame. All frames are produced in two lengths: S and M.

This construction is based on the common elements system. Different executions of motors can be made by adding the different sub-assemblies on the base type construction.

2.2. Mounting arrangements

Motors of this catalogue are produced in two standard IEC 600... arrangements:

- Horizontal shaft arrangement IBM3/IM1001/ according to IEC 34- 7 code I/code II
- Vertical shaft arrangement IMV1/IM3011/ according to IEC 34-7 code I/code II

By motors in vertical shaft arrangement, the flange is made in accordance with IEC 72-5 Publication.

On special request these motors can be produced with another fixing dimensions or in the different mechanical arrangements

2.3. Tolerances of principal dimensions

Dimensions given in bold figures are obligatory. All other dimensions are only informal. Tolerances of principal dimensions are given in the Table 2.

Table:2

Dimension		Tolerance
A		$\pm 1,5$ mm
B	up to 1000 mm above 1000 mm	$+ 2,0$ mm $\pm 2,5$ mm
C		$\pm 5,0$
D		m 6
F		h 9
GA		- 0,2
K		+ 3 %
M	up to 1000 mm above 1000 mm	+ 1,0 mm $\pm 2,5$ mm
N		j 6
S		+ 3 %

Mechanical characteristics

2.4. Mechanical protection and cooling form

Mechanical protections and methods of cooling are defined with IEC 60034-5 and IEC 60034-6 and therefore they are include in the type designation of motor.

Motors included in this catalogue can be delivered in any form of cooling method and degree of protection. Optimal choice of electric motor depends on many conditions: instalation place of electric motor, presence of solid particles in the air, air humidity, presence of water, presence of chemically aggressive gases and vapours, outside temperature and price of different solutions.

In every case it is necessary to consult the designer of electric motor and electromotive driving system to achieve a safe operation of motor and an economic solution. In the next text, the recommendations useful for choice of cooling method and mechanical protection are mentioned:

- Motors of line 1KO and 1PO are self-ventilated open machines, fan mounted on the shaft. The coolant (air) flows freely into the motor from the surrounding medium and returns freely to the medium surrounding the motor. The fan is only for one sense of rotation. These motors are designed for indoor installing in the clean surrounding medium without presence of water.
- Motors of line 1KW and 1PW are self-ventilated open machines, fan mounted on the shaft. The coolant is air from surrounding medium filtered by special filters mounted on the motor. These motors are designed for installing in moderately dust surrounding medium with presence of splashing water from any direction
- Motors of line 1KR and 1PR are enclosed with inlet or duct for clean air. Ventilation can be own, or in the case it is insufficient, the additional fan can be used, because the pressure drop in the duct is to high. Installing of these motors is recommended in dusty environment (rubber and cement industry).
- Motors of line 1KV and 1PV are totally enclosed. Motor ventilation is achived by heat exchanger which is an independent unit but is mounted directly on the motor. The primary coolant is air and the secondary collant is water. Installing of these motors is recommended on the places where watermains exist but the open motor can not be used by reason of splashing water. By low ambient temperature these executions are not preferable by reason of water freezing in the heat exchaner.
- Motors of line 1KZ and 1PZ are totally enclosed. The heat exchanger is mounted on the motor. The primary coolant is circulated in a closed circuit and gives its heat to the secondary coolant which is surrounding air. This execution is recommended for installing in the moist and moderately dust environment which do not balk the normal operation of heat exchanger and in which the splashing water occur.

Table:3

Symbol in type designations	Method of cooling I EC 60034-6/69	Short designation	Degrees of protection IEC 60034-5		
			Protection against contact	Protection against ingress	Protection against ingress of water
...O...	Self-ventilated by air circulation IC 01	IP 22	Protection against contact by finger	Protection against ingress of small solid foreign bodies greater than 12 mm	Protection against dripping water
		IP 23			Protection against drops of water falling up to 60° from the vertical
...W...	Self-ventilated by air circulation through the filter IC 01	IPW 24	Protection against contact by tools or similar objects	Protection against ingress of foreign bodies greater than 1 mm	Protection against splashing water from any direction
...R...	Inlet duct ventilated IC 31 IC 37 A	IPR 44/ /IC 31, IP 33/ /IC 37, IP 44/			
...V...	Cooling with heat exchanger air-water IC W 81	IP 44 (IP 54)	Complete protection against contact	Protection against harmful deposits of dust	
...Z...	Self-ventilated with heat-exchanger air-air IC 01 61				

Inside ventilation of high speed motors is axial one with centrifugal fan as it is shown in fig – 1. Hladan vazduhstruji kroz radialne ventilacione kanale lipaketa rotora i statora. Unutrašnji ventilator je radialjan.

The cold air circulates through the axial ventilation ducts of rotor core, air-gap, winding heads and between core and frame. Inside ventilation of low speed motors is radial one as it is shown in fig – 2. The cold air circulates through the radial ventilation ducts of stator and rotor core. Internal fan is radial one.

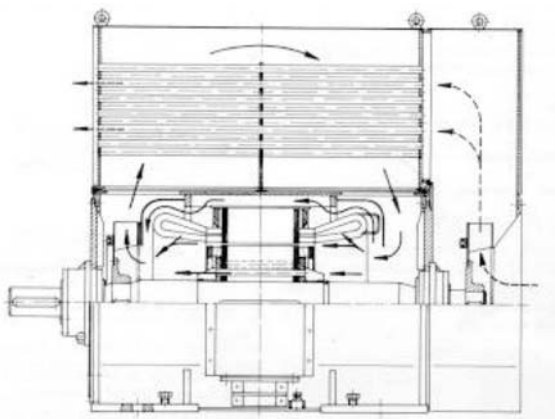

Fig. 1.
Ventilation of high speed motors

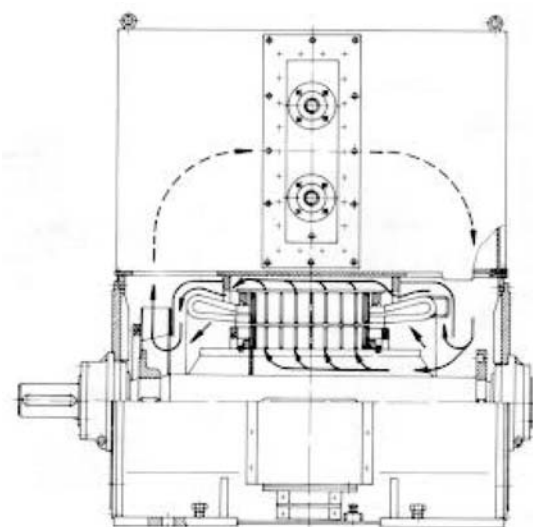

Fig. 2.
Ventilation of low speed motors

2.5. Shaft and bearings

Dimensions of shaft ends and wedges are standardized in accordance with IEC 60072 and DIN 42946. Standard motors are designed for direct coupled drives with elastic coupling.

On special request motors can be delivered with two free shaft ends or with non-standard dimensions of shaft end.

The bearing sets are provided with regulator of grease quantity and lubricating nipple which make lubrication possible while motor is running.

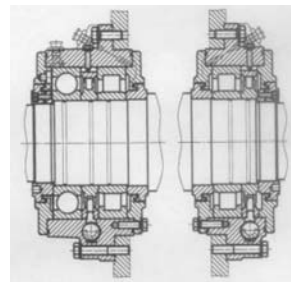

Fig. 3.
Bearing arrangement for horizontal shaft motor

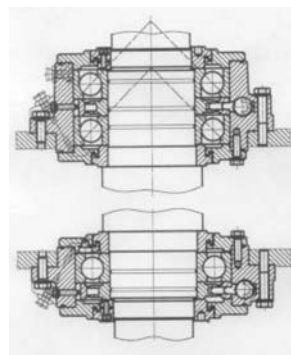

Fig. 4.
Bearing arrangement for vertical shaft motor

On the motor frame (end shields) there are placed name plates with bearing data: type, grease quantity (for one bearing set) and lubrication period.

The proper maintenance of bearings ensures a running life time at least 50000 hours for number of poles 4 and more than 4 and 40000 hours for 2 poles motors.

Mechanical characteristics

6

For lubrication of these motors the following greases are use:

- INA LIPLEKS EP3 with following characteristics:
lithium based grease: mineral oil
working temperature from -30°C up to +130°C
drop point 220°C
- FOR PD2
lithium based grease: mineral oil
working temperature from -30°C up to +150°C
drop point 190°C

For following frame sizes 355, 400 and 450 by 2 poles motors the used grease is FOR PD2 (table:4), and for number of poles more than 2 the used grease is INA LIPLEKS EP3.

Table: 4

Frame size	Number of poles	Types of roller bearings for mounting arrangement IM B3 (IM 1001)	
		Drive end Immovable bearings	Non drive end Movable bearings
355	2	NU 216 M.C3+6216 M.C4	NU 216 M.C3
	4 - 6	NU 220 M.C3+6220 M.C3	NU 220 M.C3
400	2	NU 216 M.C3+6216 M.C4	NU 216 M.C3
	4 - 10	NU 222 M.C3+6222 M.C3	NU 222 M.C3
450	2	NU 218 M.C3+6218 M.C4	NU 218 M.C3
	4 - 12	NU 224 M.C3+6224 M.C3	NU 224 M.C3 ¹⁾
500	2	-*	-*
	4 - 12	NU 226 M.C3+6226 M.C4	NU 226 M.C3 ¹⁾
560	2	-*	-*
	4 - 12	NU 230 M.C3+6230 M.C4	NU 230 M.C3 ¹⁾

Table: 5

Frame size	Number of poles	Types of roller bearings for mounting arrangement IM V1 (IM 3001)	
		Drive end Immovable bearings	Non drive end Movable bearings
355	2	6216 M.C3	2 x 7126 B.UA
	4 - 6	6220 M	2 x 7220 B.UA
400	2	-*	-*
	4 - 10	6222 M	2 x 7222 B.UA
450	2	-*	-*
	4 - 12	6224 M.C3 ²⁾	2 x 7224 B.MP.UA ³⁾
500	2	-*	-*
	4 - 12	6226 M.C3 ²⁾	2 x 7226 B.MP.UA ³⁾
560	2	-*	-*
	4 - 12	6230 M.C3 ¹⁾	2 x 7230 B.MP.UA ³⁾

* - on special inquiry

¹⁾ - for 2p=6 motors and more poles, without marks M

²⁾ - for 2p=6 motors and more poles, without marks M.C3

³⁾ - for 2p=6 motors and more poles, without marks MP

It is important to note that re-greasing must be done even in the case that motor is out of exploitation. In this case the re-greasing period is at least two years.

In the table 6. there are shown the quantity of grease and usually intervals of lubrication for corresponding bearings. For extreme conditions (high temperature, dust etc.) please consult the factory.

Table: 6

Motor side	Bearing type	Quantity of grease [cm ³]	Re-greasing interval (working hours)					
			Number of poles					
			2	4	6	8	10	12
Drive side	NU 216+6216	22	950	-	-	-	-	-
	NU 218+6218	28	850	-	-	-	-	-
	NU 220+6220	38	-	2200	4000	5800	7200	8000
	NU 222+6222	44	-	1800	3400	5000	6500	7800
	NU 224+6224	52	-	3000	3100	4400	5400	6700
	NU 226+6226	60	-	2600	2800	4000	5000	6500
	NU 230+6230	76	-	1700	1800	2800	4000	5000
	6216	11	1800	-	-	-	-	-
	6220	19	-	3400	6500	8000	8000	8000
	6222	22	-	2800	5600	7800	8000	8000
	6224	26	-	4800	5000	7200	8000	8000
	6226	38	-	4200	4500	7000	8000	8000
6230	38	-	2800	3000	4500	6500	8000	
Non-drive side	NU 216	11	950	-	-	-	-	-
	NU 218	14	850	-	-	-	-	-
	NU 220	19	-	2200	4000	5800	7200	8000
	NU 222	22	-	1800	3400	5000	6500	7800
	NU 224	26	-	3000	3100	4400	5400	6700
	NU 226	30	-	2600	2800	4000	5500	6500
	NU 230	38	-	1700	1800	2800	4000	5000
	2 x 7126	22	700	-	-	-	-	-
	2 x 7220	38	-	1450	2900	4500	5900	8000
	2 x 7222	44	-	1260	2400	4200	5900	7500
	2 x 7224	52	-	2000	2000	3600	5000	6500
	2 x 7226	60	-	1700	1700	3200	4500	6000
2 x 7230	76	-	1300	1200	2400	3600	4500	

The table is valid for grease ShellAlvania R3, for framed range Kluber Staburags NBU 8EP or for other corresponding grease.

2.6. TERMINAL BOXES

2.6.1. Stator terminal box

The terminal box is designed in accordance with DIN 42962 and it is shown in Fig. 5.

In the terminal box there are placed: 3 terminal screws which are going through 3 porcelain insulators. The terminal screws M 12 are in accordance with DIN 46200 and they can be loaded up to 315 A.

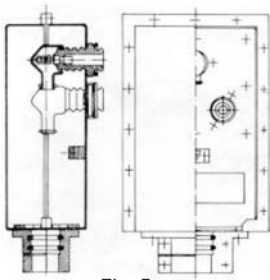

Fig. 5.
Terminal box of stator winding

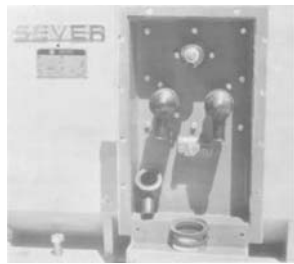

Fig. 6.
View of the stator terminal

In the terminal box, beside the terminal screws, it is earthing screw also. The beginnings of all three phases are led out to the terminal screws, and insulated star point is situated inside the motor. On special request motors can be delivered with two separate terminal boxes. In this case the both ends of each phase are led out to the terminal boxes. The terminal box is welded of steel sheets and degree of protection IP 55. The standard terminal box position is on the right hand side looking at the drive end of the motor, but it can be provided on the left side when requested. Standard cable entry is turned down but it can be turned through 90°C and 190°C.

Standard cable entries are:

1 x ϕ (60 ÷ 80) or

2 x ϕ (50 ÷ 70)

On the back side of terminal box there is a membrane by reason of expansion caused by pressure. On this way the personal is protected against explosion.

2.6.2. Rotor terminal box

Rotor terminal box is designed and produced in accordance with DIN 46944 and it is shown in the figure 6.

In the rotor terminal box there are placed 6 terminal screws M 16 which can be loaded up to 800 A. In the terminal box, beside the terminal screws, it is earthing screw also. In the most cases the rotor winding is connected in the star and the star point is insulated in the motor. The winding ends are led out to

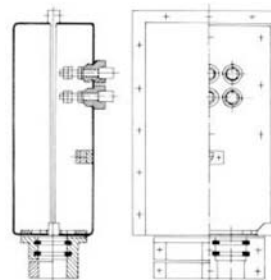

Fig. 7.
Rotor terminal box



Fig. 8.
View of the rotor terminal box

the brushes and terminal screws. Terminal box is made of welded steel sheets, enclosure IP 55. Terminal box is placed on the right side, but it can be placed on the left side if it is requested.

Cable entries are:

1 x ϕ (60 ÷ 80) or

2 x ϕ (50 ÷ 70)

The cable entry is in the down position but it can be turned for 90° or 180°.

2.6.3. Terminal box for heaters and indicators

In the case of motor equipped with indicators of temperature or heaters the separate terminal box is provided for their terminals.



Fig. 9.

Terminal box of the thermometers for winding and bearings

2.7. Stator core and winding

Stator core is produced of laminations of high magnetic performance, small w^{at} losses, thickness of 0,5 mm, varnish insulated on the both side withstands high temperature. Stator core is insert type that means that the laminations are composed at first, fixed and after that the complete winding is insert in it. After all stator core with winding is impressed in the motor frame.

Advantage of this type of construction is in the fact that the winding impregnation is made outside of the motor frame.

The stator winding is double layer with short winding pitch and the copper wire E-CuF20 and its dimensions are in accordance with DIN 46452. The wire insulation is LGGL i.e. enamel varnish and combination of the glass silk and varnish. The main insulation is on the base of mica paper and epoxid resin. The insulation system is class F and accords to IEC 60034-1.

After the coils are formed the main insulation is carried on the smooth parts of the coils are baked in the press on the right dimension. On this way the insulation becomes compact without pores, stable in the form and life time practically without smoulding at rated voltage. The special formed passing over the flat insulation toward the winding head and special impregnation of the winding head results in the great mechanical and electrical strenght and resistance against the moisture. The completed coils are protected with semiconductive varnish in order to better the linking of the electrostatic field. $\tan \delta$ is in accordance with VDE 0530.

Advantage of discontinual system is in a fact that eventual repair is easy and can be made on the damaged part.

For exeptional humidity and aggressive enwironments as well as for re-starting conditions the special impregnation system is used.

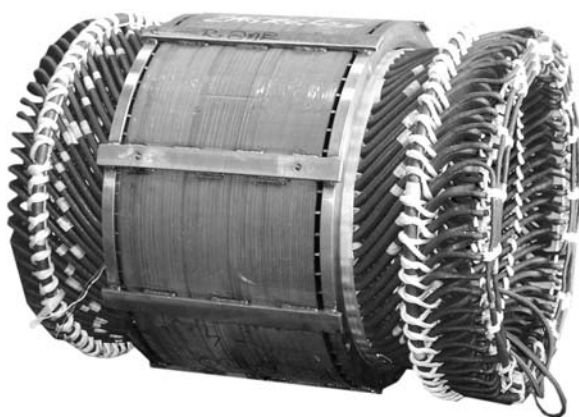

Fig. 10.
Stator core and winding

2.8. Rotor core and winding

Rotor core is produced of laminations and placed directly on the shaft of horizontal high speed motors but at low speed motors on the shaft star. Rotor is balanced together with fan and wedge on high sensitive balance machine.

2.8.1. Cage rotor

The cage is made of copper profile. Rotor bars and cage rings are joined by means of special method of welding.

This method allows a high temperature of cage during the starting up to 300°C, long life and high reliability. Rotor is deep-bar.

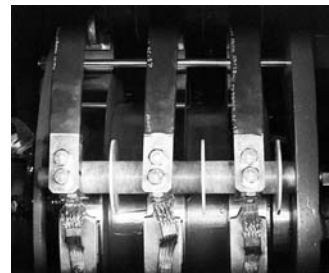

Fig. 11.
Slip-rings and brush holders

For heavy duty on special request rotor cage can be produced of special copper alloy with great strength and thermal capacity. On this way high starting torque and small starting current is achieved an this enables a big number of starting and acceleration of great Moment of inertia.

2.8.2. Slip ring rotor

Rotor winding of slip-ring motor is made of electrolytic copper ECuF20.

Insulation system of the winding corresponds to the insulation class "F". The ends of the winding are welded and good mechanical properties and persistence are achieved. Since the ends are connected the complete rotor is impregnated.

Standard slip-ring motors are designed with constant leaning brushes. The slip rings are placed outside the motor, to prevent the harmful influence of the graphite dust and to achieve an easy maintenance. The slip rings are made of copper-nickel alloy to ensure long life time and small wearing. The brushes are made of brass-graphite and they are impregnated. The choice of brushes and slip rings ensures the life time, the time of minimum one year of continual operation.

The used brushes are:

- K 14 Z3 producer Schunk & EBE GMBH
- CG 75/J producer Carbone.

3. ELECTRICAL CHARACTERISTICS

3.1. Voltage and frequency

The standard supply voltage and frequency for high voltage motors from this catalogue are 6 kV and 50 Hz.

Motors can be wound to special order, for voltages from 3 to 10 kV and frequency 60 Hz. The lower output limit for voltage 10 kV is 400 kW..

3.2. Rated output

The rated outputs given in this catalogue are valid for continual duty type S1 and following conditions:

- voltage 6 kV
- ambient temperature not exceeding 40 °C
- altitude above sea level up to 1000 m
- coolant (Water) temperature on the entry of heat exchanger not exceeding 27 °C
- temperature rise of water 5 °C
- water test pressure 10 bar
- pressure of water up to 6 bar
- water pressure drop 0,5 bar

If these conditions are not satisfied, the admissible output of motor must be corrected to the Figures 12, 13, 14, 15 and 16.

Temperature rises by the rated conditions are below allowed for insulation class "F". This reserve can be used in the cases of short time overload, voltage drop etc.

3.3. Overload

Motors of this catalogue at operating temperature are capable of withstanding for 2 minutes 1,5 times the rated current at rated voltage. Such an overload is in accordance with VDE 0530 and will not result in excessive heating. The new overloading can occur only after 30 minutes.

3.4. Starting torque and current

The ratios of starting torque and starting current as well as the ratio of pull out torque i.e. current are given in the schedules of electrical data.

If the supply voltage deviates from its rated value, starting torque, pull-up and pull out torque change with the square of the voltage, whereas the starting current changes linearly. The allowed Moment of inertia of the driven machine is given in the tables. These values are valid for three starting in the case that load torque is a square function $M=f(n^2)$. In all other cases, for example $M=f(n)$, this value is to be adjusted.

Standard motors will withstand three starts in succession from cold state, under rated conditions and two starts with the motor at normal running temperature.

The tolerances of quoted values are in accordance with IEC 60034-1 and VDE 0530:

- for starting current +20 %
- for starting torque -15 % +25%
- for pull out torque -10 %
- but not less than 1,6 Mn

Table: 7

H (m)	Θ [°C]
1000	40
2000	30
3000	20
400	10

Table: 8

Cooling water temperature °C	Permissible output %
27	100
28	99
29	98
30	97
31	96
32	95
33	94

Output remains constant as these conditions

Correction of the motor output (cooling with heat exchanger-air water)

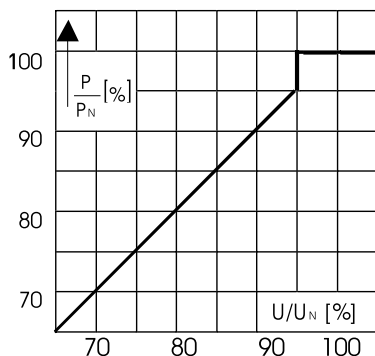

Fig. 12. Output in the function of voltage temperature

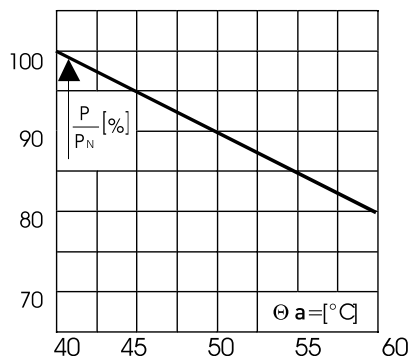

Fig. 13. Output in the function of ambient of altitude

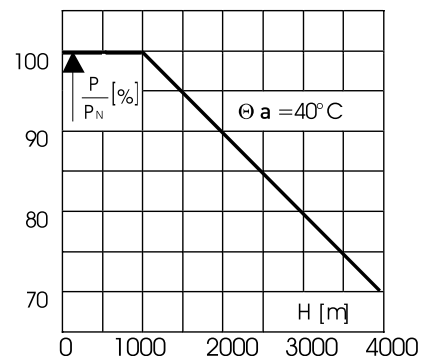

Fig. 14. Output diagram as a function

3.5. Speed

The values of the rotational speed, expressed in min^{-1} refer to the loaded motor with rated torque and normal running temperature. These values are rounded.

The tolerances of the speed are defined as the tolerances of the slip $\pm 20\%$. Standard motors are delivered for clockwise sense of rotation, viewed from the drive and of the motor. The sense of rotation is signed by the arrow on the name (UVW) plate and on the plate for rotation sense on the front side of the motor. For two sense of rotation or for anticlockwise sense of rotation this fact must be requested in the order, because the fans are designed only for clockwise rotation. The sign for birotational machine is (WUV) and for anticlockwise (VUW) or (WUW). In the case that motor is designed for two sense of rotation efficiency is less for 0,5, 1,0% from this given in the data sheets.

- It is prohibited to use the motor for reversible duty or for electric braking with contra-current without the consultation.
- Without the confirmation, the slip-ring motor can not be used for speed regulation, because the decreasing the speed aggravates the cooling conditions.
- On the request the motors can be delivered for two speed or for speed different from those given in the data sheets.

3.6. Efficiency and power factor

The values of efficiency and power factor given in the data sheets are valid for rated supply voltage and frequency for 125%, 100%, 75%, 50% and 25% for rated output P_N :

- The tolerance for the efficiency values is

$$- \frac{1-h}{10}$$

but not less than 0,007.

- The tolerance for the power factor values is

$$- \frac{1-\cos\phi}{6}$$

but not less than 0,02 and not more than 0,07.

3.7. Noise

The noise levels of standard motors quoted in this catalogue comply with the recommendations of IEC 60034-9 measured in accordance with ISOR 1680.

For special requirements the noise level can be reduced below the standard values.

3.8. Vibrations

Motor vibrations are derived from effective speed of vibrations in mm/s.

All rotors are dynamically balanced. Standard motors comply with range "b", VDI 2056 and range "a" in the case of special request. Measuring instruments and methods are in accordance with DIN 45666. The test is taken on no-load running on rated voltage and frequency and the amplitude of vibration is measured at the bearing end-shields.

3.9. Testing motors

The tests specified in this part are normally made in our test station. In the case of prototype the basic tests will be done in accordance with VDE 0530. Depending on the request the motor can be tested according to other standards in the presence of the purchaser or his representative. Except the standard tests in the case of special request the additional test can be done. Additional tests can be made at the manufacturer's works or on the place of their application. When test certificate is required, it shall be requested at the time of ordering.

3.9.1. Standard testings

- Control of fixing dimensions
- Control of the air gap
- Control of the auxiliary components
- Resistance test of windings
- Insulation resistance test
- Control of marking and sense of rotation
- Routine check test
- No load losses and current test and determination of no load power factor at rated voltage
- Locked rotor test, determination of losses, current and power factor at standstill and reduced voltage
- High voltage test
- Over-speed test

3.9.2. Additional testings

- Testing of no-load characteristics
- Testing of locked rotor characteristics
- Oscillography of the current, voltage and speed during the starting
- Determination of the torque-speed curve
- Determination of the Moment of inertia
- Determination of the load characteristics
- Temperature rise test
- Noise test
- Dielectric test of winding insulation
- Oscillography of residual voltage

4. FOUNDATIONS

The foundations must fill up the following conditions:

- Foundations of steel construction, high and elastic: Own critical frequency of system must be less for cca $0,7 \times n$ (T group of motors and aggregate, low adjusted $n_k < n$ according VDI 2056).
- Hard and massive concrete foundations: Own critical frequency of system must be greater for cca $1,4 \times n$ (G group of motors and aggregates high adjusted $n_k > n$ according VDI 2506).

5. ADDITIONAL EQUIPMENT

When it is requested standard motors can be equipped with additional equipment:

- PTC thermistors for motor protection
- Resistance thermometer Pt 100 for winding
- Resistance thermometer Pt 100 for bearing
- Contact thermometer for bearing
- Anti-condensation heaters for motors which are exposed to considerable fluctuations of temperature in moisture ambient
- Resistance thermometer for measuring the temperature of cold and hot air.
- Tripping device for PTC thermistors
- Anchor bolts
- Slide rails
- Stand
- Over-voltage limiter

Note: By motor with heat exchanger water-air recommend to check the temperature and circulation of water.

6. SPARE PARTS

If requested we deliver the spare parts. For important driving system we recommend the following spare parts:

- bearings
- uninsulated winding
- insulators
- brushes for slip-ring motors

7. SPECIAL REQUIREMENTS

If requested motors of this catalogue can be delivered for following requirements:

- with additional equipment according to point
- with two shaft extensions or with non standard shaft end
- with non standard fixing dimensions
- with sleeve bearings

- for two sense of rotation
- with reduced noise level
- with reduced vibrations
- special shipping
- voltage different from 6 kV
- reduced starting current and increased starting torque
- two speed motor
- special mounting arrangement
- short circuiting device for slip-ring motor
- non standard painting
- belt pulley design
- mechanical protection IP 54 and IP 55
- non standard name plate
- for high number of starting
- for additional axial bearing load
- with test report
- test report for special testing
- modification for other standards

8. REQUEST AND ORDERING

In your request or in the case of ordering please indicate the following data:

- rated output
- rated voltage and frequency
- cooling form and mechanical protection
- rated speed
- mounting arrangement
- supply conditions
- type of the driven machine
- Moment of inertia calculated on the motor shaft
- torque-speed curve of the driven machine
- number of starting per hour and number of consecutively starting
- request for starting current
- request for torque-speed curve
- overload
- place of installing and air humidity
- ambient temperature
- altitude
- position of terminal box
- sense of rotation
- other special requirements according to point 6.

Our products

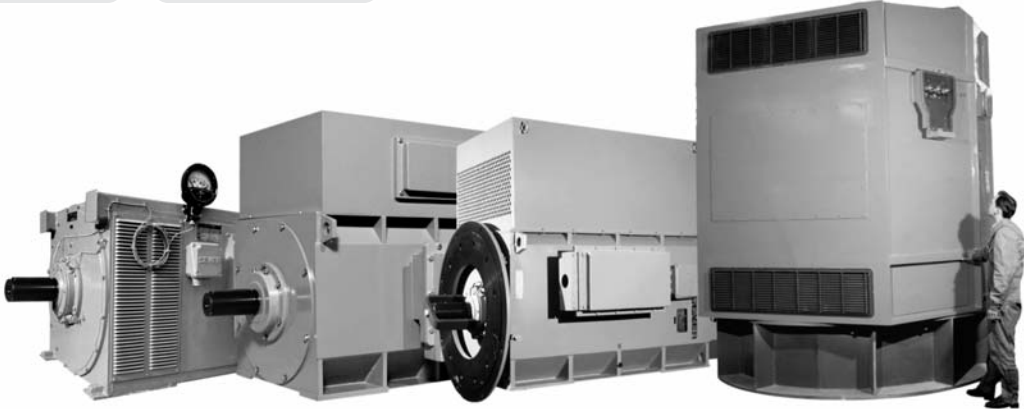
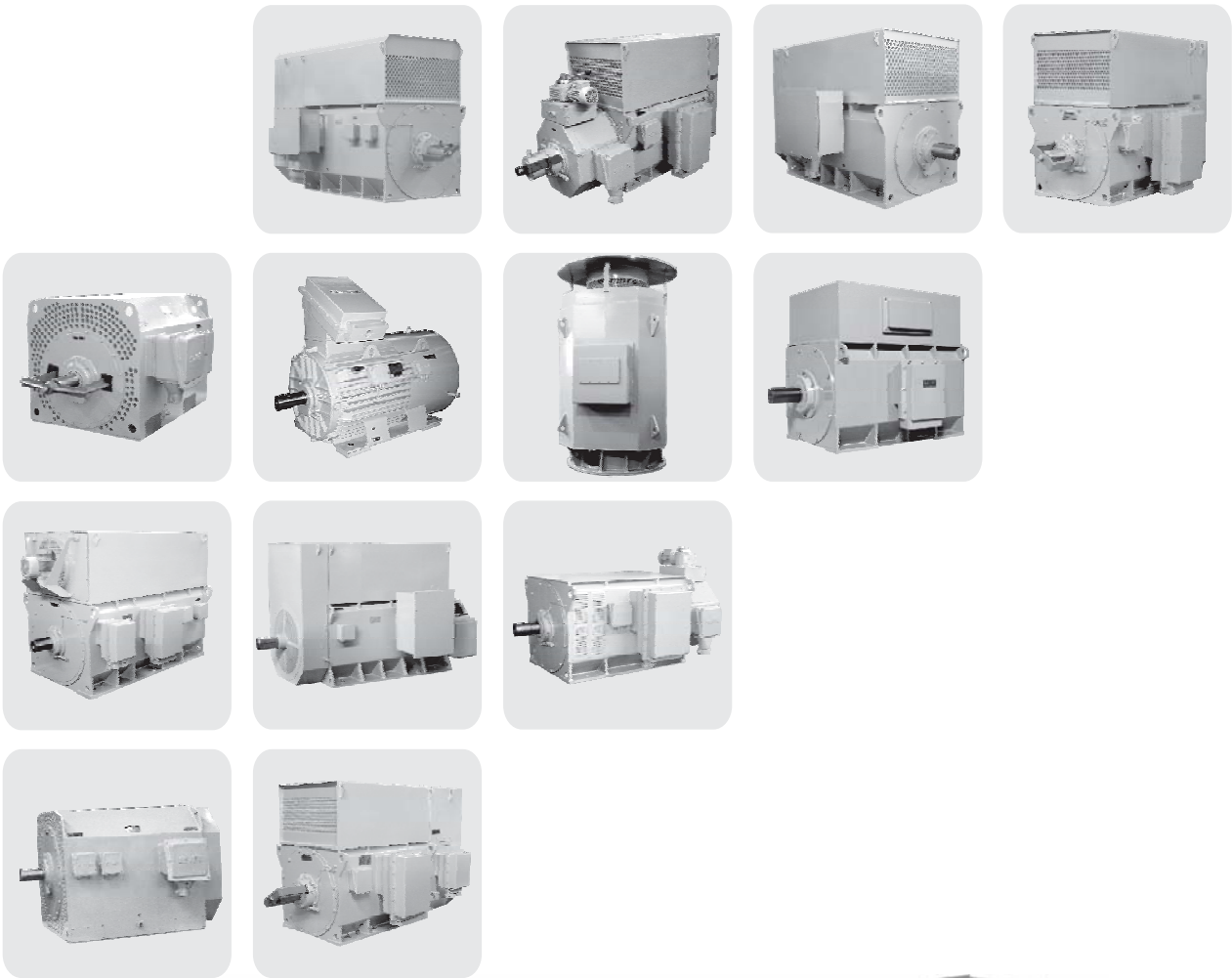

Technical data

HIGH VOLTAGE THREE PHASE
INDUCTION MOTORS WELDED
CONSTRUCTION

Type:
KR
KO
KW
KV

Protect.:
IPR 44
IP 23
IPW 24
IP 44

Cooling:
IC 31
IC 01
IC 01
IC 81W

Arrangement:
IM B3; (IM 1001)
IM V1; (IM 3011)

Execution:
Rotor: squirrel cage
Voltage: 6 kV
Frequency: 50 Hz
Insul. class: F

13

Type	Rated output	Rated speed	Efficiency η %				Power factor $\cos\phi$				Rated current	Current and torque ratios			Mom. of inertia	Weight of motor		
	P_N	n	5/4 P_N	1/1 P_N	3/4 P_N	1/2 P_N	5/4 P_N	1/1 P_N	3/4 P_N	1/2 P_N	I_N	I_P/I_N	M_P/M_N	M_{PR}/M_N	J_m	IPR 44	IPW24 IP 23	IP 44
	kW	min ⁻¹									A				kgm ²		m	kg
$n_s=3000 \text{ min}^{-1}$																		
1.K...6355 Sa-2	200	2970	92,4	93,1	92,7	91,2	0,88	0,88	0,86	0,80	23	5,2	0,64	2,4	2,2	1320	1430	1510
1.K...6355 Sb-2	225	2970	93,2	93,4	93,1	91,7	0,89	0,89	0,87	0,81	26	5,2	0,64	2,4	2,4	1355	1525	1715
1.K...6355 Sc-2	250	2970	93,4	93,6	93,3	92,1	0,89	0,89	0,87	0,81	29	5,2	0,66	2,4	2,5	1390	1560	1750
1.K...6355 Ma-2	280	2970	93,7	93,9	93,7	92,5	0,89	0,9	0,88	0,83	32	5,3	0,67	2,4	2,7	1437	1607	1847
1.K...6355 Mb-2	315	2970	94	94,2	93,9	92,8	0,9	0,9	0,88	0,83	36	5,3	0,69	2,4	2,9	1560	1730	1970
1.K...6355 Mc-2	355	2971	94,2	94,4	94,2	93,1	0,9	0,9	0,89	0,85	40	5,4	0,70	2,4	3,2	1630	1800	2040
1.K...6355 Md-2	400	2972	94,5	94,6	94,4	93,3	0,91	0,91	0,91	0,85	45	5,5	0,74	2,4	3,6	1670	1870	2010
1.K...6400 Sa-2	450	2968	93,7	94,0	93,9	93,1	0,90	0,90	0,90	0,86	51	5,0	0,60	2,1	5,0	2030	2250	2290
1.K...6400 Sb-2	500	2972	94,0	94,2	94,0	93,1	0,89	0,90	0,90	0,86	57	5,4	0,70	2,2	5,5	2150	2370	2410
1.K...6400 Ma-2	560	2974	94,1	94,5	93,5	93,4	0,90	0,90	0,90	0,85	63	5,8	0,70	2,3	6,0	2350	2570	2710
1.K...6400 Mb-2	630	2974	94,5	94,6	94,4	93,6	0,91	0,91	0,91	0,88	71	5,8	0,70	2,3	7,0	2450	2670	2810
1.K...6450 Sa-2	710	2966	94,4	94,6	94,5	93,6	0,88	0,90	0,88	0,84	80	5,0	0,70	2,2	9	2570	2850	2930
1.K...6450 Sb-2	800	2967	94,6	94,8	94,7	93,9	0,89	0,90	0,89	0,85	90	5,1	0,70	2,2	10	2850	3150	3210
1.K...6450 Ma-2	900	2968	94,8	94,9	94,8	94	0,90	0,91	0,90	0,86	100	5,2	0,75	2,2	11	3070	3350	3550
1.K...6450 Mb-2	1000	2968	94,9	95,1	94,9	94	0,91	0,91	0,90	0,86	111	5,6	0,80	2,3	12,5	3250	3530	3730
1.K...6500 Sa-2	1120																	
1.K...6500 Sb-2	1250																	
1.K...6500 Ma-2	1400																	on request
1.K...6500 Mb-2	1600																	
1.K...6500 Mc-2	1800																	
1.K...6560 Sa-2	2000																	
1.K...6560 Sb-2	2240																	on request
1.K...6560 Ma-2	2500																	
1.K...6560 Mb-2	2800																	

Note: All other motors frame sizes, executions and additional data are available on request; All quoted data are informal; Keeping back privilege for change in catalogue.

Technical data

14

HIGH VOLTAGE THREE PHASE
INDUCTION MOTORS WELDED
CONSTRUCTION

Type:
KR
KO
KW
KV

Protect.:
IPR 44
IP 23
IPW 24
IP 44

Cooling:
IC 31
IC 01
IC 01
IC 81W

Arrangement:
IM B3; (IM 1001)
IM V1; (IM 3011)

Execution:
Rotor: squirrel cage
Voltage: 6 kV
Frequency: 50 Hz
Insul. class: F

Type	Rated output	Rated speed	Efficiency η %						Power factor $\cos\phi$				Rated current	Current and torque ratios			Mom. of inertia	Weight of motor		
	P_N	n	5/4 P_N		1/1 P_N	3/4 P_N	1/2 P_N	5/4 P_N		1/1 P_N	3/4 P_N	1/2 P_N	I_N	I_F/I_N	M_F/M_N	M_{PR}/M_N	J_m	IPR 44	IPW24 IP 23	IP 44
	kW	min ⁻¹											A				kgm ²	m kg		
ns=1500 min ⁻¹																				
1.K...6355 Sa-4	200	1475	92,0	92,6	92,7	91,9	0,84	0,84	0,82	0,77	25	5,1	0,9	2,4	4,5	1360	1510	1550		
1.K...6355 Sb-4	225	1476	92,3	92,9	92,9	92,2	0,84	0,84	0,83	0,77	28	5,1	0,9	2,4	5,0	1418	1568	1608		
1.K...6355 Sc-4	250	1477	92,8	93,2	93,2	92,4	0,84	0,84	0,82	0,77	31	5,5	0,95	2,5	5,5	1430	1580	1620		
1.K...6355 Ma-4	280	1479	93,2	93,5	93,4	92,5	0,87	0,86	0,84	0,78	34	5,5	1	2,5	6,0	1500	1650	1740		
1.K...6355 Mb-4	315	1478	93,2	93,6	93,6	92,8	0,87	0,86	0,84	0,79	38	5,5	1	2,5	6,5	1610	1760	1850		
1.K...6355 Mc-4	355	1478	93,2	93,6	93,6	92,9	0,87	0,87	0,85	0,80	42	5,5	1	2,5	7,0	1656	1806	1896		
1.K...6355 Md-4	400	1478	93,6	93,9	94,0	93,2	0,87	0,87	0,85	0,80	47	5,5	1	2,5	7,5	1720	1870	1960		
1.K...6400 Sa-4	450	1477	93,4	94,0	94,2	93,6	0,88	0,88	0,87	0,81	52	5,0	0,8	2,0	11,0	2090	2310	2570		
1.K...6400 Sb-4	500	1478	93,6	94,1	94,3	93,7	0,88	0,88	0,86	0,80	58	5,0	0,8	2,0	11,5	2150	2370	2630		
1.K...6400 Ma-4	560	1479	94,1	94,5	94,6	94,0	0,88	0,88	0,87	0,80	65	5,1	0,85	2,1	13,0	2390	2610	2970		
1.K...6400 Mb-4	630	1480	94,2	94,6	94,7	94,1	0,88	0,88	0,87	0,80	73	5,1	0,85	2,1	14,5	2510	2730	3090		
1.K...6450 Sa-4	710	1480	94,6	95,0	95,2	94,8	0,89	0,91	0,90	0,88	79	5,0	0,8	1,9	21,6	2750	3030	3110		
1.K...6450 Sb-4	800	1480	94,7	95,1	95,3	94,9	0,89	0,91	0,91	0,88	89	5,0	0,8	1,9	24,3	2940	3220	3300		
1.K...6450 Ma-4	900	1482	95,0	95,2	95,4	95,0	0,9	0,91	0,91	0,88	100	5,5	0,8	1,9	26,5	3160	3440	3520		
1.K...6450 Mb-4	1000	1483	95,2	95,4	95,5	95,0	0,9	0,91	0,91	0,88	111	5,5	0,85	2,0	30,2	3360	3640	3720		
1.K...6500 Sa-4	1120	1490	95,7	95,8	95,6	94,7	0,89	0,89	0,87	0,81	125	6,2	1	2,5	52	3800	3932	4212		
1.K...6500 Sb-4	1250	1490	95,8	95,8	95,7	94,9	0,9	0,88	0,87	0,84	138	5,2	0,9	2	47	4008	4160	4420		
1.K...6500 Ma-4	1400	1490	96	95,8	95,9	95,1	0,9	0,88	0,89	0,85	154	5,2	0,9	2	50	4422	4534	4908		
1.K...6500 Mb-4	1600	1490	96	95,9	96	95	0,9	0,88	0,89	0,85	175	5,1	0,9	2	55	4630	4742	5116		
1.K...6560 Sa-4	1800	1484	95,7	96,1	96,1	95,7	0,88	0,88	0,85	0,78	206	5,1	0,9	2	59	5109	5215	5631		
1.K...6560 Sb-4	2000	1485	95,9	96,2	96,2	95,8	0,89	0,89	0,86	0,8	226	5,3	0,9	2,1	70	5667	5773	6189		
1.K...6560 Ma-4	2240	1485	95,7	96,2	95,8	95,2	0,9	0,89	0,89	0,85	247	5,4	0,9	2,3	99	5761	5771	6387		
1.K...6560 Mb-4	2500	1487	96,3	96,4	96,5	96	0,9	0,89	0,89	0,83	276	5,5	0,9	2,2	103	6394	6606	7020		
1.K...6630 Sa-4	3150																			
1.K...6630 Sb-4	3550																			on request
1.K...6630 Ma-4	4000																			
1.K...6710 Sa-4	4500																			
1.K...6710 Sb-4	5000																			on request
1.K...6710 Ma-4	5600																			
1.K...6710 Mb-4	6300																			

Note: All other motors frame sizes, executions and additional data are available on request; All quoted data are informal; Keeping back privilege for change in catalogue.

Technical data

HIGH VOLTAGE THREE PHASE
INDUCTION MOTORS WELDED
CONSTRUCTION

Type:
KR
KO
KW
KV

Protect.:
IPR 44
IP 23
IPW 24
IP 44

Cooling:
IC 31
IC 01
IC 01
IC 81W

Arrangement:
IM B3; (IM 1001)
IM V1; (IM 3011)

Execution:
Rotor: squirrel cage
Voltage: 6 kV
Frequency: 50 Hz
Insul. class: F

15

Type	Rated output	Rated speed	Efficiency η %						Power factor $\cos\phi$				Rated current	Current and torque rations			Mom. of inertia	Weight of motor		
	P_N	n	η			$\cos\phi$			I_N	rations			J_m	IPR 44	IPW24 IP 23	IP 44				
	kW	min^{-1}	5/4 P_N	1/1 P_N	3/4 P_N	1/2 P_N	5/4 P_N	1/1 P_N		3/4 P_N	1/2 P_N	I_P/I_N		M_P/M_N	M_{PR}/M_N	kgm ²	m	m	kg	
ns=1000 min ⁻¹																				
1.K...6355 Sc-6	200	984	92,5	92,7	92,4	91	0,85	0,85	0,81	0,73	24	4,6	1	2,2	10,5	1540	1690	1730		
1.K...6355 Ma-6	225	984	92,7	92,9	92,5	91	0,85	0,85	0,82	0,74	27	4,6	1	2,2	11,5	1620	1792	1842		
1.K...6355 Mb-6	250	984	93,1	93,1	92,8	91,5	0,85	0,85	0,82	0,75	30	4,4	0,9	2,2	12,5	1740	1910	2030		
1.K...6400 Sa-6	280	986	93	93,5	93,6	93	0,85	0,85	0,83	0,76	34	4,7	0,7	2,1	12,5	1940	2140	2200		
1.K...6400 Sb-6	315	986	93	93,5	93,7	93,2	0,85	0,85	0,83	0,77	38	4,4	0,7	2	12,8	2030	2230	2290		
1.K...6400 Sc-6	355	986	93	93,6	93,9	93,4	0,86	0,86	0,86	0,8	42	4,4	0,6	2	14,5	2150	2350	2410		
1.K...6400 Sd-6	400	986	93,5	94	94,2	93,8	0,86	0,86	0,86	0,8	48	4,4	0,6	2	16,2	2270	2470	2530		
1.K...6400 Ma-6	450	987	93,8	94,3	94,4	93,9	0,86	0,86	0,86	0,8	53	4,6	0,7	2	18,4	2480	2700	2740		
1.K...6400 Mb-6	500	987	94	94,5	94,6	94	0,86	0,86	0,86	0,8	59	4,5	0,6	2	20,5	2600	2820	2860		
1.K...6450 Sa-6	560	990	94,2	94,6	94,7	94,1	0,86	0,87	0,86	0,8	66	5	0,8	2	30,7	2750	3030	3130		
1.K...6450 Sb-6	630	987	94,4	94,8	94,9	94,4	0,86	0,87	0,86	0,8	74	5	0,8	2	34,5	2940	3220	3320		
1.K...6450 Ma-6	710	988	94,5	94,9	94,9	94,4	0,86	0,87	0,86	0,8	83	5	0,8	2	39,2	3160	3460	3540		
1.K...6450 Mb-6	800	989	94,7	95	95	94,4	0,87	0,87	0,86	0,8	93	5,5	0,8	2,1	43,7	3300	3600	3680		
1.K...6500 Sa-6	900	991	95,4	95,6	95,5	94,7	0,87	0,87	0,85	0,78	103	5,8	1,4	2,3	87	4153	4305	4565		
1.K...6500 Sb-6	1000	991	95,5	95,6	95,6	94,8	0,87	0,87	0,85	0,79	114	5,4	0,9	2	63	4372	4524	4784		
1.K...6500 Ma-6	1120	991	95,6	95,7	95,7	94,9	0,87	0,87	0,85	0,78	128	5,9	0,9	2,1	70	4869	4981	5355		
1.K...6500 Mb-6	1250	991	95,7	95,8	95,7	95	0,87	0,87	0,84	0,77	144	5,4	0,9	2	79	5046	5158	5532		
1.K...6560 Sa-6	1400	991	95,7	95,9	96	95,5	0,85	0,87	0,85	0,8	162	5,4	0,9	2	88	5439	5545	5960		
1.K...6560 Sb-6	1600	991	98,8	96	96,1	95,7	0,85	0,88	0,85	0,8	186	5,3	0,9	2	112	6009	6115	6531		
1.K...6560 Ma-6	1800	991	95,9	96	96,2	95,7	0,85	0,88	0,85	0,79	209	5,3	0,9	2	123	6347	6557	6973		
1.K...6560 Mb-6	2000	993	96,3	96,1	96,2	95,4	0,86	0,9	0,82	0,75	234	5,3	0,9	2	135	7018	7228	7644		
1.K...6630 Sa-6	2500																			
1.K...6630 Sb-6	2800																	on request		
1.K...6630 Ma-6	3150																			
1.K...6710 Sa-6	3550																			
1.K...6710 Sb-6	4000																	on request		
1.K...6710 Ma-6	4500																			

Note: All other motors frame sizes, executions and additional data are available on request; All quoted data are informal; Keeping back privilege for change in catalogue.

Technical data

16

HIGH VOLTAGE THREE PHASE
INDUCTION MOTORS WELDED
CONSTRUCTION

Type:
KR
KO
KW
KV

Protect.:
IPR 44
IP 23
IPW 24
IP 44

Cooling:
IC 31
IC 01
IC 01
IC 81W

Arrangement:
IM B3; (IM 1001)
IM V1; (IM 3011)

Execution:
Rotor: squirrel cage
Voltage: 6 kV
Frequency: 50 Hz
Insul. class: F

Type	Rated output	Rated speed	Efficiency η %				Power factor $\cos\phi$				Rated current	Current and torque ratios			Mom. of inertia	Weight of motor		
	P_N	n	5/4 P_N	1/1 P_N	3/4 P_N	1/2 P_N	5/4 P_N	1/1 P_N	3/4 P_N	1/2 P_N	I_N	I_p/I_N	M_p/M_N	M_{PR}/M_N	J_m	IPR 44	IPW24 IP 23	IP 44
	kW	min ⁻¹									A				kgm ²		m kg	
ns=750 min ⁻¹																		
1.K...6400 Sa-8	225	737	92	92,6	92,8	92	0,84	0,83	0,8	0,71	29	4,5	0,8	2,1	15	2010	2210	2270
1.K...6400 Sb-8	250	738	92,2	92,8	92,9	92,1	0,84	0,83	0,8	0,71	31	4,5	0,8	2,1	17	2150	2350	2410
1.K...6400 Ma-8	280	737	92,4	93	93,2	92,5	0,84	0,83	0,81	0,72	35	4,5	0,8	2,1	18	2330	2550	2690
1.K...6400 Mb-8	315	738	92,7	93,2	93,3	92,5	0,85	0,83	0,8	0,72	39	4,6	0,8	2,1	20,5	2420	2640	2720
1.K...6450 Sa-8	355	741	93,7	94	93,9	93	0,83	0,82	0,77	0,68	44	4,8	0,8	2,2	25	2827	3107	3287
1.K...6450 Sb-8	400	740	93,7	94	93,9	93	0,83	0,82	0,78	0,69	50	4,5	0,8	2,2	27	2950	3230	3330
1.K...6450 Sc-8	450	740	93,8	94,1	94	93,1	0,83	0,82	0,78	0,68	51	4,5	0,8	2,2	28,9	3090	3370	3470
1.K...6450 Ma-8	500	740	94	94,3	94,2	93,3	0,83	0,82	0,78	0,69	62	4,5	0,8	2,2	31	3270	3570	3750
1.K...6450 Mb-8	560	740	94	94,4	94,3	93,5	0,83	0,83	0,79	0,71	69	4,5	0,8	2,2	35	3380	3680	3860
1.K...6450 Mc-8	630	740	94,2	94,5	94,4	93,6	0,83	0,83	0,79	0,71	77	4,5	0,8	2,2	38	3520	3820	4000
1.K...6500 Sa-8	710	741	94,5	94,9	94,5	93,4	0,85	0,83	0,82	0,74	84	5,1	0,9	2,2	83	3644	3760	4020
1.K...6500 Sb-8	800	742	94,7	95,1	94,5	93,3	0,86	0,83	0,81	0,73	95	5,5	1	2,4	98,5	3904	4056	4316
1.K...6500 Ma-8	900	743	94,8	95,1	94,5	93,1	0,86	0,83	0,81	0,73	107	5,9	1,1	2,5	121	4256	4638	5016
1.K...6500 Mb-8	1000	743	94,9	95,2	94,5	93	0,86	0,83	0,8	0,71	119	6,2	1,1	2,7	137	4734	4846	5220
1.K...6560 Ma-8	1120	744	95,7	95,3	95,5	94,6	0,85	0,85	0,8	0,72	134	6,1	1	2,3	192	5482	5692	6108
1.K...6560 Mb-8	1250	744	95,8	95,4	95,5	94,5	0,84	0,85	0,8	0,69	151	6,4	1,05	2,3	206	6282	6492	6908
1.K...6630 Sa-8	1600																	
1.K...6630 Sb-8	1800																	
1.K...6630 Ma-8	2000																	on request
1.K...6630 Mb-8	2240																	
1.K...6710 Sa-8	2500																	
1.K...6710 Sb-8	2800																	
1.K...6710 Ma-8	3150																	on request
1.K...6710 Mb-8	3550																	

Note: All other motors frame sizes, executions and additional data are available on request; All quoted data are informal; Keeping back privilege for change in catalogue.

Technical data

HIGH VOLTAGE THREE PHASE
INDUCTION MOTORS WELDED
CONSTRUCTION

Type:
KR
KO
KW
KV

Protect.:
IPR 44
IP 23
IPW 24
IP 44

Cooling:
IC 31
IC 01
IC 01
IC 81W

Arrangement:
IM B3; (IM 1001)
IM V1; (IM 3011)

Execution:
Rotor: squirrel cage
Voltage: 6 kV
Frequency: 50 Hz
Insul. class: F

17

Type	Rated output P _N	Rated speed n	Efficiency η %				Power factor cosφ				Rated current I _N	Current and torque ratios			Mom. of inertia J _m kgm ²	Weight of motor		
			5/4 P _N	1/1 P _N	3/4 P _N	1/2 P _N	5/4 P _N	1/1 P _N	3/4 P _N	1/2 P _N		I _P /I _N	M _P /M _N	M _{PR} /M _N		IPR 44	IPW24 IP 23	IP 44
	kW	min ⁻¹																
ns=600 min ⁻¹																		
1.K...6400 Sb-10	200	590	92,2	92,5	92,3	91	0,78	0,76	0,7	0,59	27	4,5	0,8	2,2	20	2110	2260	2300
1.K...6400 Ma-10	225	590	92,3	92,7	92,6	91,4	0,8	0,78	0,73	0,62	30	4,4	0,7	2,1	22	2210	2380	2450
1.K...6400 Mb-10	250	591	92,7	93	92,8	91,6	0,8	0,77	0,72	0,61	34	4,4	0,7	2,1	24	2330	2720	2790
1.K...6450 Sa-10	280	591	92,4	92,7	92,5	91,3	0,8	0,78	0,73	0,61	37	4,8	1,2	2,1	36	2640	2840	2900
1.K...6450 Sb-10	315	591	93	93,3	93,2	92,3	0,81	0,8	0,76	0,66	41	4,5	1	2	41	2800	3000	3060
1.K...6450 Ma-10	355	591	93	93,4	93,3	92,4	0,81	0,8	0,76	0,66	46	4,5	1,1	2	44	2970	3190	3330
1.K...6450 Mb-10	400	591	93,1	93,5	93,5	92,7	0,81	0,8	0,78	0,69	52	4,5	1,1	2	49	3135	3355	3495
1.K...6500 Sa-10	450	592	94	94,2	94	92,7	0,81	0,79	0,74	0,63	58	4,9	1,1	2,2	93	3612	3764	4024
1.K...6500 Sb-10	500	592	94,1	94,3	94,1	93,1	0,82	0,8	0,76	0,66	64	4,8	1,1	2,1	101	3862	4014	4276
1.K...6500 Ma-10	550	592	94,1	94,4	94,3	93,3	0,82	0,81	0,77	0,68	69,2	4,7	1	2	110	4558	4690	5044
1.K...6500 Mb-10	630	592	94,3	94,4	94,2	93,1	0,81	0,79	0,74	0,63	81,3	5	1,1	2,1	118	4869	4981	5255
1.K...6560 Sa-10	710	592	94,3	94,6	94,5	93,6	0,82	0,78	0,78	0,69	88,4	5,2	1,4	2,1	162	5252	5358	5774
1.K...6560 Sb-10	800	592	94,4	94,7	94,6	93,8	0,82	0,78	0,79	0,7	99,2	5,1	1,4	2	176	5801	5907	6323
1.K...6560 Ma-10	900	592	94,5	94,8	94,8	93,9	0,82	0,78	0,79	0,7	111,5	5,1	1,4	2	189	5935	6561	6821
1.K...6560 Mb-10	1000	592	94,4	94,6	94,4	93,4	0,82	0,78	0,78	0,7	124,5	5,1	1,4	2	203	6530	6770	7186
1.K...6630 Sa-10	1250																	
1.K...6630 Sb-10	1400																	
1.K...6630 Ma-10	1600																	
1.K...6710 Sa-10	1800																	
1.K...6710 Sb-10	2000																	
1.K...6710 Ma-10	2240																	
1.K...6710 Mb-10	2500																	

Note: All other motors frame sizes, executions and additional data are available on request; All quoted data are informal; Keeping back privilege for change in catalogue.

Technical data

18

HIGH VOLTAGE THREE PHASE
INDUCTION MOTORS WELDED
CONSTRUCTION

Type:
KR
KO
KW
KV

Protect.:
IPR 44
IP 23
IPW 24
IP 44

Cooling:
IC 31
IC 01
IC 01
IC 81W

Arrangement:
IM B3; (IM 1001)
IM V1; (IM 3011)

Execution:
Rotor: squirrel cage
Voltage: 6 kV
Frequency: 50 Hz
Insul. class: F

Type	Rated output	Rated speed	Efficiency η %				Power factor $\cos\phi$				Rated current	Current and torque rations			Mom. of inertia	Weight of motor		
	P_N	n	5/4 P_N	1/1 P_N	3/4 P_N	1/2 P_N	5/4 P_N	1/1 P_N	3/4 P_N	1/2 P_N	I_N	I_F/I_N	M_F/M_N	M_{PR}/M_N	J_m	IPR 44	IPW24 IP 23	IP 44
	kW	min ⁻¹									A				kgm ²	m kg		
ns=500 min ⁻¹																		
1.K...6450 Sa-12	225	488	91,0	91,5	91,5	90,3	0,78	0,75	0,69	0,55	32	4,4	1,1	2,2	46	2920	3210	3310
1.K...6450 Sb-12	250	489	91,3	91,8	91,6	90,3	0,78	0,75	0,69	0,56	35	4,3	1,1	2,3	51,7	2970	3250	3350
1.K...6450 Ma-12	280	489	91,7	92	91,7	90,3	0,78	0,75	0,69	0,56	39	4,5	1,2	2,4	59,8	3124	3424	3604
1.K...6450 Mb-12	315	489	91,8	92,2	92,0	90,7	0,78	0,75	0,7	0,58	43	4,3	1,1	2,3	65,5	3234	3534	3714
1.K...6500 Sa-12	355	493	93	93,2	92,8	91,2	0,76	0,74	0,68	0,56	49,5	4,1	1	2,2	87	3692	3648	4108
1.K...6500 Sb-12	400	493	93	93,2	92,7	91,2	0,75	0,72	0,66	0,54	57,4	4,1	1	2,2	96	4008	4160	4620
1.K...6500 Ma-12	450	493	93,1	93,4	92,9	91,3	0,76	0,74	0,68	0,57	62,6	4,1	1	2,1	114	4734	4846	5220
1.K...6500 Mb-12	500	493	93,4	93,5	93,1	91,6	0,76	0,74	0,69	0,58	69,5	4,1	1	2,1	132	4942	5054	5428
1.K...6560 Sa-12	560	496	94,2	93,9	93,1	91	0,78	0,75	0,7	0,59	76	5,5	1,8	2,2	220	5163	5269	5685
1.K...6560 Sb-12	630	496	94,3	94,1	93,3	91,4	0,78	0,76	0,7	0,6	84	5,4	1,8	2,1	251	5770	5876	6292
1.K...6560 Ma-12	710	496	94,4	94,2	93,5	91,6	0,78	0,77	0,72	0,62	94	5,3	1,8	2,1	277	5848	6058	6474
1.K...6560 Mb-12	800	496	94,4	94,1	93,3	91,3	0,77	0,76	0,71	0,6	94	5,4	1,8	2,1	307	6550	6760	7176
1.K...6630 Sa-12	1000																	
1.K...6630 Sb-12	1120																	
1.K...6630 Ma-12	1250																	
1.K...6710 Sa-12	1400																	
1.K...6710 Sb-12	1600																	
1.K...6710 Ma-12	1800																	
1.K...6710 Mb-12	2000																	

Note: All other motors frame sizes, executions and additional data are available on request; All quoted data are informal; Keeping back privilege for change in catalogue.

Technical data

HIGH VOLTAGE THREE PHASE
INDUCTION MOTORS WELDED
CONSTRUCTION

Type:
KZ

Protect.:
IP 44

Cooling:
IC 611

Arrangement:
IM B3; (IM 1001)
IM V1; (IM 3011)

Execution:
Rotor: squirrel cage
Voltage: 6 kV
Frequency: 50 Hz
Insul. class: F

19

Type	Rated output	Rated speed	Efficiency η %				Power factor $\cos\phi$				Rated current	Current and torque rations			Mom. of inertia	Weight of motor
	P_N kW	n min^{-1}	5/4 P_N	1/1 P_N	3/4 P_N	1/2 P_N	5/4 P_N	1/1 P_N	3/4 P_N	1/2 P_N	I_N A	I_P/I_N	M_P/M_N	M_{PR}/M_N	J_m kgm^2	IPR 44 m kg
ns=3000 min^{-1}																
1.KZ...6355 Sc-2	200	2972	92,5	92,3	91,4	89,2	0,9	0,9	0,89	0,83	23	5,5	0,68	2,52	3,5	1690
1.KZ...6355 Ma-2	225	2976	92,85	92,5	91,6	89,3	0,9	0,9	0,86	0,8	26	6,5	0,83	2,9	3,7	1740
1.KZ...6355 Mb-2	250	2972	93,1	92,9	92,2	90,2	0,91	0,91	0,89	0,85	29	5,54	0,7	2,5	3,9	1860
1.KZ...6355 Mc-2	280	2972	93,3	93,2	92,5	90,6	0,92	0,92	0,91	0,87	31	5,5	0,7	2,5	4,2	1930
1.KZ...6355 Md-2	315	2973	93,6	93,5	92,8	91,03	0,92	0,92	0,91	0,88	35	5,6	0,7	2,5	4,6	1970
1.KZ...6400 Sa-2	355	2972	93,1	93	92,4	90,7	0,9	0,9	0,9	0,87	41	5,3	0,7	2,4	6,5	2390
1.KZ...6400 Sb-2	400	2974	93,4	93,2	92,5	90,8	0,91	0,91	0,91	0,87	45	5,7	0,8	2,5	7	2510
1.KZ...6400 Ma-2	450	2974	93,5	93,4	92,5	91,1	0,91	0,91	0,91	0,88	51	5,7	0,8	2,5	7,5	2710
1.KZ...6400 Mb-2	500	2975	93,8	93,6	92,9	90,4	0,92	0,92	0,91	0,89	56	5,7	0,8	2,5	8,5	2810
1.KZ...6450 Sa-2	560	2976	93,8	93,3	92,7	90,8	0,89	0,912	0,86	0,8	70	6,19	1,23	2,78	12	2970
1.KZ...6450 Sb-2	630	2980	93,8	93,4	92,8	90,4	0,89	0,928	0,87	0,8	70	6,37	1,19	2,84	13	3250
1.KZ...6450 Ma-2	710	2975	94,3	94	93,3	91,5	0,9	0,9	0,88	0,81	81	6,4	1	2,6	14	3470
1.KZ...6450 Mb-2	800	2976	94,3	94,2	93,9	91,76	0,9	0,9	0,89	0,82	91	6,5	1,1	2,7	15,5	3650
1.KZ...6500 Sa-2	900															
1.KZ...6500 Sb-2	1000															
1.KZ...6500 Ma-2	1120															on request
1.KZ...6500 Mb-2	1250															
1.KZ...6500 Mc-2	1400															
1.KZ...6560 Sa-2	1600															
1.KZ...6560 Sb-2	1800															on request
1.KZ...6560 Ma-2	2000															
1.KZ...6560 Mb-2	2240															

Note: All other motors frame sizes, executions and additional data are available on request; All quoted data are informal; Keeping back privilege for change in catalogue.

Technical data

20

HIGH VOLTAGE THREE PHASE
INDUCTION MOTORS WELDED
CONSTRUCTION

Type:
KZ

Protect.:
IP 44

Cooling:
IC 611

Arrangement:
IM B3; (IM 1001)
IM V1; (IM 3011)

Execution:
Rotor: squirrel cage
Voltage: 6 kV
Frequency: 50 Hz
Insul. class: F

Type	Rated output	Rated speed	Efficiency η %				Power factor $\cos\phi$				Rated current	Current and torque ratios			Mom. of inertia	Weight of motor
	P_N	n	5/4 P_N	1/1 P_N	3/4 P_N	1/2 P_N	5/4 P_N	1/1 P_N	3/4 P_N	1/2 P_N	I_N	I_p/I_N	M_p/M_N	M_{PR}/M_N	J_m	IPR 44
	kW	min^{-1}									A				kgm^2	m kg
ns=1500 min^{-1}																
1.KZ...6355 Sc-4	200	1480	92,5	92,6	92,2	90,8	0,9	0,9	0,88	0,82	23	6	1,06	2,8	6,5	1730
1.KZ...6355 Ma-4	225	1481	92,9	92,9	95,5	91	0,91	0,91	0,88	0,82	26	6,3	1,11	2,9	7	1800
1.KZ...6355 Mb-4	250	1481	92,9	93	92,7	91,4	0,91	0,91	0,88	0,83	28	6,1	1,1	2,8	7,5	1910
1.KZ...6355 Mc-4	280	1480	93,1	93,2	92,6	91,7	0,91	0,91	0,89	0,84	32	5,9	1,03	2,7	8	1956
1.KZ...6355 Md-4	315	1480	93,5	93,7	92,5	92,3	0,92	0,92	0,89	0,85	35	5,7	1,03	2,6	8,5	2120
1.KZ...6400 Sa-4	355	1481	93,4	93,5	92,4	92,6	0,88	0,88	0,86	0,79	42	5,6	1	2,3	12,5	2450
1.KZ...6400 Sb-4	400	1481	93,7	93,8	93,6	92,5	0,88	0,88	0,86	0,79	47	5,6	1	2,3	13	2510
1.KZ...6400 Ma-4	450	1481	93,9	94	93,7	92,6	0,88	0,88	0,87	0,81	52	5,7	1	2,3	14,5	2750
1.KZ...6400 Mb-4	500	1482	94,1	94,2	93,9	93,8	0,88	0,88	0,87	0,81	58	5,8	1	2,3	16	2870
1.KZ...6450 Sa-4	560	1480	94,5	94,5	94,5	93,1	0,9	0,9	0,89	0,85	63	5,5	0,9	2,3	23,6	3150
1.KZ...6450 Sb-4	630	1480	94,7	93,8	94,7	93,3	0,9	0,9	0,89	0,85	71	5,5	0,9	2,3	27,3	3340
1.KZ...6450 Ma-4	710	1480	94,9	94	94,9	93,4	0,9	0,9	0,89	0,85	80	5,8	0,9	2,3	29,5	3560
1.KZ...6450 Mb-4	800	1480	95	94,2	94	93,5	0,9	0,9	0,89	0,85	90	5,9	0,9	2,3	33,2	3760
1.KZ...6500 Sa-4	900	1490	95	95,3	94,5	93,1	0,91	0,88	0,88	0,84	100	6,3	1	2,6	51	4212
1.KZ...6500 Sb-4	1000	1490	95,3	95,4	94,7	93,4	0,91	0,88	0,88	0,86	110	6,2	1	2,6	54	4420
1.KZ...6500 Ma-4	1120	1490	95,4	95,5	94,7	93,6	0,91	0,88	0,88	0,87	122	6,1	1	2,5	59	4908
1.KZ...6500 Mb-4	1250	1491	95,5	95,6	95	93,7	0,91	0,88	0,88	0,88	136	6,2	1	2,5	63	5116
1.KZ...6560 Sa-4	1400	1485	95,4	95,5	95,3	94,5	0,9	0,9	0,9	0,86	155	5,8	0,8	2,3	66	5839
1.KZ...6560 Sb-4	1600	1485	95,5	95,6	95,5	94,7	0,9	0,91	0,9	0,87	176	5,7	0,8	2,3	74	6399
1.KZ...6560 Ma-4	1800	1485	95,6	95,7	95,6	94,8	0,91	0,91	0,9	0,87	197	5,9	0,8	2,3	84	6647
1.KZ...6560 Mb-4	2000	1487	96,2	96,4	96,4	95,9	0,9	0,89	0,88	0,82	277	6,8	0,8	2,6	98	7280
1.KZ...6630 Sa-4	2500															
1.KZ...6630 Sb-4	2800															on request
1.KZ...6630 Ma-4	3150															
1.KZ...6710 Sa-4	3550															
1.KZ...6710 Sb-4	4000															on request
1.KZ...6710 Ma-4	4500															
1.KZ...6710 Mb-4	5000															

Note: All other motors frame sizes, executions and additional data are available on request; All quoted data are informal; Keeping back privilege for change in catalogue.

Technical data

HIGH VOLTAGE THREE PHASE
INDUCTION MOTORS WELDED
CONSTRUCTION

Type:
KZ

Protect.:
IP 44

Cooling:
IC 611

Arrangement:
IM B3; (IM 1001)
IM V1; (IM 3011)

Execution:
Rotor: squirrel cage
Voltage: 6 kV
Frequency: 50 Hz
Insul. class: F

21

Type	Rated output	Rated speed	Efficiency η %				Power factor $\cos\phi$				Rated current	Current and torque rations			Mom. of inertia	Weight of motor
	P_N kW	n min^{-1}	5/4 P_N	1/1 P_N	3/4 P_N	1/2 P_N	5/4 P_N	1/1 P_N	3/4 P_N	1/2 P_N	I_N A	I_P/I_N	M_P/M_N	M_{PR}/M_N	J_m kgm^2	IPR 44 m kg
$n_s=1000 \text{ min}^{-1}$																
1.KZ...6400 Sa-6	225	988	93,3	93,4	93,1	91,9	0,86	0,84	0,82	0,73	28	5,4	0,9	2,3	14	2300
1.KZ...6400 Sb-6	250	987	93,1	93,4	93,3	92,2	0,87	0,85	0,83	0,75	30	5,1	0,8	2,3	14,3	2390
1.KZ...6400 Sc-6	280	987	93,2	93,5	93,4	92,4	0,87	0,86	0,84	0,77	34	5,1	0,8	2,3	16	2510
1.KZ...6400 Sd-6	315	988	93,5	94	93,7	93,7	0,87	0,86	0,84	0,77	38	5,1	0,8	2,3	17,7	2630
1.KZ...6400 Ma-6	355	988	94	94,1	93,9	92,9	0,87	0,86	0,84	0,77	42	5,1	0,8	2,3	19,9	2840
1.KZ...6400 Mb-6	400	988	93,9	94,1	93,9	92,9	0,87	0,86	0,84	0,78	48	5	0,8	2,9	22	2960
1.KZ...6450 Sa-6	450	990	94,3	94,3	94	92,8	0,87	0,86	0,83	0,76	53	5,6	0,9	2,3	33,7	3150
1.KZ...6450 Sb-6	500	990	94,4	94,5	94,1	93	0,88	0,87	0,84	0,77	59	5,6	0,9	2,3	37,3	3340
1.KZ...6450 Ma-6	560	990	94,4	94,6	94,2	93,1	0,88	0,87	0,85	0,77	66	5,7	0,9	2,4	42,2	3560
1.KZ...6450 Mb-6	630	990	94,7	94,7	94,3	93,1	0,88	0,87	0,84	0,75	74	6	1	2,4	47	3700
1.KZ...6500 Sa-6	710	991	95	95	94,6	92,8	0,88	0,87	0,85	0,79	81	6	1,4	2,4	87	4565
1.KZ...6500 Sb-6	800	991	95,1	95,1	94,8	93	0,88	0,88	0,86	0,8	91	5,8	1,4	2,3	95	4784
1.KZ...6500 Ma-6	900	991	95,3	95,3	94,9	93,1	0,88	0,88	0,86	0,8	103	5,8	1,4	2,3	103	5355
1.KZ...6500 Mb-6	1000	991	95,4	95,4	95	93,1	0,88	0,87	0,86	0,8	114	6	1,4	2,3	111	5532
1.KZ...6560 Sa-6	1120	991	95,3	95,5	95,3	94,5	0,86	0,87	0,86	0,82	129	5	0,8	1,9	110	6169
1.KZ...6560 Sb-6	1250	991	95,4	95,6	95,4	94,6	0,86	0,87	0,86	0,82	144	5	0,8	1,9	120	6739
1.KZ...6560 Ma-6	1400	992	95,6	95,7	95,5	94,7	0,86	0,87	0,86	0,82	160	5	0,8	1,9	130	7233
1.KZ...6560 Mb-6	1600	993	95,9	95,9	95,6	94,6	0,87	0,87	0,86	0,82	182	5	0,8	2	162	7904
1.KZ...6630 Sa-6	2000															
1.KZ...6630 Sb-6	2240															on request
1.KZ...6630 Ma-6	2500															
1.KZ...6710 Sa-6	2800															
1.KZ...6710 Sb-6	3150															on request
1.KZ...6710 Ma-6	3550															

Note: All other motors frame sizes, executions and additional data are available on request; All quoted data are informal; Keeping back privilege for change in catalogue.

Technical data

22

HIGH VOLTAGE THREE PHASE
INDUCTION MOTORS WELDED
CONSTRUCTION

Type:
KZ

Protect.:
IP 44

Cooling:
IC 611

Arrangement:
IM B3; (IM 1001)
IM V1; (IM 3011)

Execution:
Rotor: squirrel cage
Voltage: 6 kV
Frequency: 50 Hz
Insul. class: F

Type	Rated output	Rated speed	Efficiency η %				Power factor $\cos\phi$				Rated current	Current and torque ratios			Mom. of inertia	Weight of motor
	P_N	n	5/4 P_N	1/1 P_N	3/4 P_N	1/2 P_N	5/4 P_N	1/1 P_N	3/4 P_N	1/2 P_N	I_N	I_p/I_N	M_p/M_N	M_{PR}/M_N	J_m	IPR 44
	kW	min ⁻¹									A				kgm ²	m kg
ns=750 min ⁻¹																
1.KZ...6400 Sa-8	180	740	92,4	92,5	92,1	90,5	0,83	0,8	0,75	0,64	23	5,5	0,9	2,3	16,5	2370
1.KZ...6400 Sb-8	200	736	92,5	92,7	92,5	91,1	0,84	0,82	0,79	0,7	25	5,5	0,9	2,3	18,5	2510
1.KZ...6400 Ma-8	225	739	92,5	92,9	92,4	91,1	0,84	0,83	0,79	0,7	28	5,5	0,9	2,3	19,5	2690
1.KZ...6400 Mb-8	250	739	92,8	93,1	92,9	92,9	0,84	0,83	0,79	0,7	31	5,5	0,9	2,3	22	2750
1.KZ...6450 Sa-8	280	742	93,6	93,5	93	91,5	0,83	0,8	0,75	0,64	36	5	0,9	2,3	28	3230
1.KZ...6450 Sb-8	315	742	93,6	93,6	93,1	91,5	0,83	0,81	0,77	0,66	40	5	0,9	2,3	30	3350
1.KZ...6450 Sc-8	355	742	93,8	93,8	93,3	91,9	0,83	0,81	0,77	0,66	45	5	0,9	2,3	31,9	3490
1.KZ...6450 Ma-8	400	743	93,9	93,9	93,6	92,2	0,83	0,82	0,8	0,68	44,8	5,18	0,82	3,64	34	3670
1.KZ...6450 Mb-8	450	742	94	93,16	93,7	92,5	0,83	0,78	0,8	0,7	56,7	5	0,77	3,67	38	3780
1.KZ...6450 Mc-8	500	743	94,3	93,9	93,9	92,7	0,83	0,82	0,8	0,7	62	5,18	0,74	3,66	41	3920
1.KZ...6500 Sa-8	560	742	94,2	94,2	93,7	92,2	0,86	0,86	0,83	0,75	66	5,4	1	2,4	83	4020
1.KZ...6500 Sb-8	630	742	94,3	94,2	93,7	92,1	0,87	0,86	0,83	0,75	74	5,6	1	2,5	98,5	4316
1.KZ...6500 Ma-8	710	743	94,4	94,3	93,7	92	0,87	0,86	0,83	0,76	83	5,9	1	2,6	121	5012
1.KZ...6500 Mb-8	800	743	94,5	94,3	93,7	92,1	0,87	0,86	0,83	0,76	93	5,8	1	2,5	137	5220
1.KZ...6560 Ma-8	900	744	95,2	9,2	94,7	93,4	0,85	0,84	0,81	0,73	107	6	1	2,3	192	6368
1.KZ...6560 Mb-8	1000	744	95,3	95,2	94,8	93,5	0,85	0,84	0,81	0,73	119	6	1	2,3	275	7168
1.KZ...6630 Sa-8	1400															
1.KZ...6630 Sb-8	1600															
1.KZ...6630 Ma-8	1800															
1.KZ...6630 Mb-8	2000															
on request																
1.KZ...6710 Sa-8	2240															
1.KZ...6710 Sb-8	2500															
1.KZ...6710 Ma-8	2800															
1.KZ...6710 Mb-8	3150															
on request																

Note: All other motors frame sizes, executions and additional data are available on request; All quoted data are informal; Keeping back privilege for change in catalogue.

Technical data

HIGH VOLTAGE THREE PHASE
INDUCTION MOTORS WELDED
CONSTRUCTION

Type:
KZ

Protect.:
IP 44

Cooling:
IC 611

Arrangement:
IM B3; (IM 1001)
IM V1; (IM 3011)

Execution:
Rotor: squirrel cage
Voltage: 6 kV
Frequency: 50 Hz
Insul. class: F

23

Type	Rated output	Rated speed	Efficiency η %				Power factor $\cos\phi$				Rated current	Current and torque rations			Mom. of inertia	Weight of motor
	P_N kW	n min^{-1}	5/4 P_N	1/1 P_N	3/4 P_N	1/2 P_N	5/4 P_N	1/1 P_N	3/4 P_N	1/2 P_N	I_N A	I_P/I_N	M_P/M_N	M_{PR}/M_N	J_m kgm^2	IPR 44 m kg
ns=600 min^{-1}																
1.KZ...6400 Sb-10	160	592	92,1	92	91,2	89,1	0,76	0,72	0,64	0,51	23	5,2	1	2,5	21,5	2470
1.KZ...6400 Ma-10	180	592	92,5	92,4	91,7	89,8	0,77	0,74	0,67	0,55	25	5,1	0,9	2,5	23,5	2570
1.KZ...6400 Mb-10	200	593	92,6	92,5	91,8	89,8	0,77	0,74	0,66	0,54	28	5,1	0,9	2,5	25,5	2690
1.KZ...6450 Sa-10	225	592	92,5	92,6	92,2	90,5	0,8	0,79	0,75	0,64	30	5	1,1	2,3	39	3040
1.KZ...6450 Sb-10	250	592	92,9	93	92,5	91	0,8	0,79	0,74	0,63	33	5	1,1	2,3	44	3200
1.KZ...6450 Ma-10	280	592	93	93,1	92,6	91,1	0,8	0,79	0,74	0,63	37	5	1,1	2,3	47	3370
1.KZ...6450 Mb-10	315	592	93,2	93,3	92,9	91,5	0,8	0,8	0,76	0,66	41	5	1,1	2,3	52	3540
1.KZ...6500 Sa-10	355	592	93,7	93,7	93,3	91,8	0,82	0,81	0,76	0,67	45	4,9	1,1	2,2	93	4024
1.KZ...6500 Sb-10	400	593	93,8	93,8	93,3	91,8	0,82	0,81	0,76	0,66	50,6	5	1,1	2,2	101	4274
1.KZ...6500 Ma-10	450	593	93,9	94	93,6	92,2	0,82	0,81	0,77	0,68	56,9	4,8	1	2,1	110	5044
1.KZ...6500 Mb-10	500	592	94	94,1	93,8	92,5	0,82	0,82	0,78	0,7	62,3	4,6	1	2,1	118	5355
1.KZ...6560 Sa-10	560	593	94	93,6	92,5	92,5	0,83	0,82	0,78	0,69	70	5,5	1,5	2,2	162	5982
1.KZ...6560 Sb-10	630	593	94	93,8	92,5	92,5	0,83	0,82	0,79	0,7	78	5,3	1,5	2,1	176	6531
1.KZ...6560 Ma-10	710	593	94,3	94	92,7	92,7	0,83	0,83	0,79	0,7	87,7	5,2	1,4	2,1	190	6821
1.KZ...6560 Mb-10	800	593	94,4	94	93	93	0,83	0,83	0,79	0,7	98,5	5,2	1,4	2,1	203	7446
1.KZ...6630 Sa-10	1120															
1.KZ...6630 Sb-10	1250															on request
1.KZ...6630 Ma-10	1400															
1.KZ...6710 Sa-10	1600															
1.KZ...6710 Sb-10	1800															on request
1.KZ...6710 Ma-10	2000															
1.KZ...6710 Mb-10	2240															

Note: All other motors frame sizes, executions and additional data are available on request; All quoted data are informal; Keeping back privilege for change in catalogue.

Technical data

24

HIGH VOLTAGE THREE PHASE
INDUCTION MOTORS WELDED
CONSTRUCTION

Type:
KZ

Protect.:
IP 44

Cooling:
IC 611

Arrangement:
IM B3; (IM 1001)
IM V1; (IM 3011)

Execution:
Rotor: squirrel cage
Voltage: 6 kV
Frequency: 50 Hz
Insul. class: F

Type	Rated output	Rated speed	Efficiency η %				Power factor $\cos\phi$				Rated current	Current and torque rations			Mom. of inertia	Weight of motor
	P_N kW	n min^{-1}	5/4 P_N	1/1 P_N	3/4 P_N	1/2 P_N	5/4 P_N	1/1 P_N	3/4 P_N	1/2 P_N	I_N A	I_p/I_N	M_p/M_N	M_{pr}/M_N	J_m kgm^2	IPR 44 m kg
ns=500 min^{-1}																
1.KZ...6450 Sa-12	180	491	91,2	91,1	91,1	90	88,0	0,74	0,71	0,62	27	5,1	1,5	2,6	49	3330
1.KZ...6450 Sb-12	200	491	91,4	91,4	91,3	90,5	88,3	0,75	0,71	0,63	30	5	1,5	2,6	54,7	3370
1.KZ...6450 Ma-12	225	492	91,7	91,4	91,5	90,6	88,3	0,75	0,71	0,63	34	5	1,5	2,6	62,8	3524
1.KZ...6450 Mb-12	250	492	91,9	91,9	91,7	90,9	88,7	0,76	0,71	0,64	37	4,9	1,4	2,6	60,5	3634
1.KZ...6500 Sa-12	280	493	93	93	92,5	90,8	0,78	0,76	0,7	0,59	38	4	1	2,1	93	4108
1.KZ...6500 Sb-12	315	493	93,2	93,2	92,7	91	0,78	0,75	0,7	0,59	43,4	4	1	2,1	96	4420
1.KZ...6500 Ma-12	355	493	93,2	93,1	92,5	90,6	0,76	0,74	0,68	0,56	49,6	4,8	1,1	2,1	114	5220
1.KZ...6500 Mb-12	400	493	93,4	93,4	92,8	91,1	0,78	0,75	0,7	0,58	55	4,3	1	2,2	191,4	5428
1.KZ...6560 Sa-12	450	496	93,6	93,2	92,2	89,7	0,79	0,78	0,71	0,6	60,5	5,7	1,8	2,2	220	5893
1.KZ...6560 Sb-12	500	496	93,7	93,3	92,3	90	0,79	0,77	0,7	0,63	66,2	5,45	1,7	2,1	250	6500
1.KZ...6560 Ma-12	560	496	93,8	93,5	92,5	90,3	0,79	0,78	0,73	0,64	73,6	5,4	1,6	2,1	276	6734
1.KZ...6560 Mb-12	630	496	94	93,6	92,7	90,5	0,79	0,78	0,74	0,65	82,2	5,3	1,5	2	308	7436
1.KZ...6630 Sa-12	800															
1.KZ...6630 Sb-12	900															
1.KZ...6630 Ma-12	1000															
1.KZ...6630 Mb-12	1120															
1.KZ...6710 Sa-12	1250															
1.KZ...6710 Sb-12	1400															
1.KZ...6710 Sc-12	1600															

on request

on request

Note: All other motors frame sizes, executions and additional data are available on request; All quoted data are informal; Keeping back privilege for change in catalogue.

Technical data

HIGH VOLTAGE THREE PHASE
INDUCTION MOTORS WELDED
CONSTRUCTION

Type:
PR
PO
PW
PV

Protect.:
IPR 44
IP 23
IPW 24
IP 44

Cooling:
IC 31
IC 01
IC 01
IC 81W

Arrangement:
IM B3; (IM 1001)
IM V1; (IM 3011)

Execution:
Rotor: slip ring
Voltage: 6 kV
Frequency: 50 Hz
Insul. class: F

25

Type	Rated output P _N kW	Rated speed n min ⁻¹	Efficiency η %				Power factor cosφ				Rated current I _N A	Rotor voltage U ₂₀ V	Rotor current I ₂₀ A	Max. torque M _{pr} /M _N	Mom. of inertia J _m kgm ²	Weight of motor			
			5/4 P _N	1/1 P _N	3/4 P _N	1/2 P _N	5/4 P _N	1/1 P _N	3/4 P _N	1/2 P _N						IPR 44	IPW24 IP 23	IP 44	
																m	kg	kg	
ns=1500 min ⁻¹																			
1.P...6355 Sa-4	200	1478	90,3	90,1	91,1	90,3	0,84	0,84	0,83	0,76	25	329	381	2	5,1	1650	1660	1816	
1.P...6355 Sb-4	225	1480	90,9	91,5	91,8	91,1	0,86	0,87	0,85	0,8	27	364	386	2	5,6	1708	1688	1844	
1.P...6355 Sc-4	250	1480	91	91,7	91,8	90,9	0,85	0,86	0,83	0,76	31	404	383	2,2	6,1	1720	1730	1886	
1.P...6355 Ma-4	280	1481	91,8	92,2	92,1	91,2	0,86	0,85	0,82	0,75	34	454	379	2,4	7,1	1820	1830	1990	
1.P...6355 Mb-4	315	1481	92,3	92,7	92,6	91,8	0,86	0,86	0,84	0,77	38	486	399	2,3	7,6	1930	1940	2100	
1.P...6355 Mc-4	355	1481	92,3	92,7	92,7	92	0,86	0,86	0,84	0,77	43	520	420	2,3	8,1	1978	1986	2145	
1.P...6355 Md-4	400	1481	92,6	93	93	92,3	0,86	0,86	0,84	0,78	48	561	439	2,3	8,6	2040	2050	2210	
1.P...6400 Sa-4	450	1483	93,7	94,2	94,3	93,7	0,84	0,84	0,82	0,75	55	520	536	1,9	12,6	2430	2440	2610	
1.P...6400 Sb-4	500	1483	94,1	94,5	94,6	94	0,84	0,84	0,82	0,74	61	561	550	2	13,1	2490	2500	2670	
1.P...6400 Ma-4	560	1485	94,4	94,7	94,7	94	0,85	0,85	0,83	0,75	67	640	536	2	14,4	2820	2830	3000	
1.P...6400 Mb-4	630	1485	94,6	94,9	94,9	94,2	0,86	0,85	0,84	0,76	75	706	546	2	16,4	2940	2950	3120	
1.P...6450 Sa-4	710	1480	93,6	94	94,1	93,6	0,86	0,87	0,86	0,83	84	700	627	1,9	28,9	3520	3530	3710	
1.P...6450 Sb-4	800	1481	93,9	94,2	94,3	93,8	0,87	0,88	0,87	0,84	93	777	632	2,1	31,6	3710	3720	3900	
1.P...6450 Ma-4	900	1482	94,1	94,4	94,4	93,9	0,87	0,88	0,87	0,83	104	875	628	2,1	34,3	4030	4040	4220	
1.P...6450 Mb-4	1000	1484	94,3	94,5	94,4	93,9	0,88	0,88	0,87	0,83	116	1000	606	2,2	38	4230	4240	4420	
1.P...6500 Sa-4	1120	1486	95,4	95,5	95,4	94,6	0,89	0,89	0,87	0,81	126	1172	579	2,6	52	4164	4316	4576	
1.P...6500 Sb-4	1250	1487	95,6	95,7	95,9	94,8	0,9	0,9	0,89	0,84	138	1278	590	2,5	59	4372	4524	4784	
1.P...6500 Ma-4	1400	1487	95,8	95,9	95,7	95	0,91	0,91	0,9	0,85	153	1406	598	2,5	65	4786	4898	5272	
1.P...6500 Mb-4	1600	1488	95,9	96	95,9	95,1	0,91	0,91	0,9	0,85	175	1562	613	2,6	72	4994	5106	5480	
1.P...6560 Sa-4	1800	1484	95,8	96,1	96,2	95,9	0,89	0,9	0,89	0,85	199	1406	781	2,2	66	5504	5610	6026	
1.P...6560 Sb-4	2000	1485	96	96,2	96,3	95,9	0,9	0,89	0,89	0,85	220	1562	777	2,3	74	6062	6168	6584	
1.P...6560 Ma-4	2240	1486	96,1	96,4	96,4	95,9	0,9	0,9	0,89	0,84	246	1758	770	2,4	84	6156	6366	6782	
1.P...6560 Mb-4	2500	1483	96,3	96,5	96,5	96	0,91	0,91	0,89	0,85	273	2009	746	2,6	98	6789	6999	7415	
1.P...6630 Sa-4	3150																		
1.P...6630 Sb-4	3550																		
1.P...6630 Ma-4	4000																		
1.P...6710 Sa-4	4500																		
1.P...6710 Sb-4	5000																		
1.P...6710 Ma-4	5600																		
1.P...6710 Mb-4	6300																		

Note: All other motors frame sizes, executions and additional data are available on request; All quoted data are informal; Keeping back privilege for change in catalogue.

Technical data

26

HIGH VOLTAGE THREE PHASE
INDUCTION MOTORS WELDED
CONSTRUCTION

Type:
PR
PO
PW
PV

Protect.:
IPR 44
IP 23
IPW 24
IP 44

Cooling:
IC 31
IC 01
IC 01
IC 81W

Arrangement:
IM B3; (IM 1001)
IM V1; (IM 3011)

Execution:
Rotor: slip ring
Voltage: 6 kV
Frequency: 50 Hz
Insul. class: F

Type	Rated output P _N kW	Rated speed n min ⁻¹	Efficiency η %				Power factor cosφ				Rated current I _N A	Rotor		Max. torque M _{pr} /M _N	Mom. of inertia J _m kgm ²	Weight of motor		
			5/4 P _N	1/1 P _N	3/4 P _N	1/2 P _N	5/4 P _N	1/1 P _N	3/4 P _N	1/2 P _N		U ₂₀ V	I ₂₀ A			IPR 44	IPW24 IP 23	IP 44
ns=1000 min ⁻¹																		
1.P...6355 Sc-6	200	990	93,3	93,3	92,8	91,2	0,84	0,83	0,79	0,69	25	410	259	2,4	11,1	1830	1840	1996
1.P...6355 Ma-6	225	990	93,4	93,4	92,9	91,3	0,84	0,83	0,79	0,69	28	454	302	2,4	12,6	1942	1952	2112
1.P...6355 Mb-6	250	989	93,7	93,7	93,3	91,8	0,84	0,83	0,8	0,71	31	550	317	2,3	13,6	2060	2070	2230
1.P...6400 Sa-6	280	986	92,9	93,5	93,6	93	0,83	0,82	0,71	0,69	35	446	387	2	14,1	2280	2290	2460
1.P...6400 Sb-6	315	985	92,8	93,5	93,7	93,3	0,84	0,83	0,8	0,72	39	460	425	2	14,4	2370	2380	2550
1.P...6400 Sc-6	355	985	92,9	93,6	93,9	93,4	0,85	0,84	0,82	0,74	43	513	430	2	16,1	2490	2500	2670
1.P...6400 Sd-6	400	986	93,5	94	94,2	93,7	0,85	0,84	0,82	0,74	48	575	430	2	17,8	2610	2620	2820
1.P...6400 Ma-6	450	987	93,9	94,4	94,5	93,9	0,85	0,84	0,81	0,73	55	654	422	2	20,3	2910	2920	3090
1.P...6400 Mb-6	500	988	94,1	94,5	94,6	94	0,86	0,85	0,82	0,75	60	721	425	2	22,4	3030	3040	3210
1.P...6450 Sa-6	560	987	93,8	94	94,1	93,4	0,83	0,83	0,81	0,73	69	746	465	2	38	3240	3250	3430
1.P...6450 Sb-6	630	987	94	94,3	94,3	93,7	0,85	0,84	0,82	0,75	77	828	468	2,1	41,8	3430	3440	3620
1.P...6450 Ma-6	710	987	94,2	94,5	94,5	93,8	0,85	0,85	0,83	0,76	85	933	466	2,1	47	3750	4760	3940
1.P...6450 Mb-6	800	988	94,4	94,6	94,5	93,8	0,85	0,85	0,82	0,74	96	1065	457	2,2	51,5	3890	3900	4080
1.P...6500 Sa-6	900	992	95,6	95,7	95,6	94,8	0,89	0,88	0,85	0,78	102	1220	443	2,7	87	4517	4669	4929
1.P...6500 Sb-6	1000	992	95,7	95,8	95,7	94,9	0,89	0,88	0,85	0,78	113	1330	450	2,7	95	4736	4888	5148
1.P...6500 Ma-6	1120	992	95,8	95,9	95,8	95	0,89	0,88	0,85	0,78	127	1463	457	2,8	103	5233	5345	5719
1.P...6500 Mb-6	1250	992	96	96	95,8	95	0,87	0,88	0,84	0,76	142	1626	458	3	111	5410	5522	5896
1.P...6560 Sa-6	1400	990	95,5	95,6	95,6	94,8	0,88	0,88	0,87	0,82	160	1330	640	2,1	109	5825	5940	6356
1.P...6560 Sb-6	1600	990	95,8	96	96,1	95,6	0,88	0,88	0,86	0,82	182	1463	666	2,1	120	6404	6510	6926
1.P...6560 Ma-6	1800	990	95,9	96,1	96,2	95,6	0,87	0,88	0,86	0,82	205	1625	671	2,2	130	6742	6952	7368
1.P...6560 Mb-6	2000	993	96,3	96,4	96,2	95,4	0,88	0,88	0,84	0,78	227	2090	572	2,5	163	7413	7623	8039
1.P...6630 Sa-6	2500																	
1.P...6630 Sb-6	2800																	
1.P...6630 Ma-6	3150																	
1.P...6710 Sa-6	3550																	
1.P...6710 Sb-6	4000																	
1.P...6710 Ma-6	4500																	

Note: All other motors frame sizes, executions and additional data are available on request; All quoted data are informal; Keeping back privilege for change in catalogue.

Technical data

HIGH VOLTAGE THREE PHASE
INDUCTION MOTORS WELDED
CONSTRUCTION

Type:
PR
PO
PW
PV

Protect.:
IPR 44
IP 23
IPW 24
IP 44

Cooling:
IC 31
IC 01
IC 01
IC 81W

Arrangement:
IM B3; (IM 1001)
IM V1; (IM 3011)

Execution:
Rotor: slip ring
Voltage: 6 kV
Frequency: 50 Hz
Insul. class: F

27

Type	Rated output P _N kW	Rated speed n min ⁻¹	Efficiency η %				Power factor cosφ				Rated current I _N A	Rotor voltage U ₂₀ V	Rotor current I ₂₀ A	Max. torque M _{pr} /M _N	Mom. of inertia J _m kgm ²	Weight of motor		
			5/4 P _N	1/1 P _N	3/4 P _N	1/2 P _N	5/4 P _N	1/1 P _N	3/4 P _N	1/2 P _N						IPR 44	IPW24 IP 23	IP 44
n _s =750 min ⁻¹																		
1.P...6400 Sa-8	225	737	91,7	92,3	92,4	91,6	0,81	0,8	0,75	0,64	29	424	330	2	16,6	2350	2360	2530
1.P...6400 Sb-8	250	737	91,9	92,5	92,6	91,7	0,82	0,8	0,76	0,65	33	475	325	2,1	18,6	2490	2500	2670
1.P...6400 Ma-8	280	737	92,1	92,7	92,8	92	0,82	0,8	0,76	0,66	36	505	343	2,1	19,9	2820	2830	3000
1.P...6400 Mb-8	315	738	92,5	93	93	92,1	0,82	0,8	0,76	0,65	41	577	336	2,2	22,4	2840	2860	3030
1.P...6450 Sa-8	355	741	92,9	93,1	92,9	91,9	0,8	0,79	0,74	0,64	46	576	378	2,2	32,3	3517	3327	3507
1.P...6450 Sb-8	400	741	93	93,2	93,1	92,1	0,8	0,79	0,74	0,63	52	618	395	2,2	34,3	3540	3450	3630
1.P...6450 Sc-8	450	741	93,2	93,4	93,3	92,5	0,8	0,8	0,75	0,65	58	672	410	2,2	36,2	3580	3590	3770
1.P...6450 Ma-8	500	741	93,3	93,5	93,4	92,5	0,81	0,8	0,76	0,66	64	733	416	2,2	38,8	3870	3870	4050
1.P...6450 Mb-8	560	742	93,5	93,7	93,6	92,7	0,82	0,81	0,77	0,67	71	808	423	2,2	42,8	3970	3980	4160
1.P...6450 Sc-8	630	742	93,6	93,8	93,7	92,8	0,83	0,81	0,77	0,67	80	898	427	2,3	45,8	4110	4120	4300
1.P...6500 Sa-8	710	740	94,5	94,7	94,6	93,6	0,86	0,85	0,83	0,75	84	692	623	2,2	83	4008	4124	4384
1.P...6500 Sb-8	800	741	94,7	94,8	94,5	93,4	0,86	0,85	0,82	0,74	94	817	591	2,3	98,5	4268	4420	4680
1.P...6500 Ma-8	900	743	94,8	94,8	94,4	93,1	0,86	0,85	0,82	0,73	106	999	540	2,5	121,5	4890	5002	5376
1.P...6500 Mb-8	1000	743	94,9	94,8	94,4	93	0,86	0,85	0,81	0,72	118	1124	532	2,7	137	5098	5210	5584
1.P...6560 Ma-8	1120	743	95,7	95,7	95,5	94,5	0,87	0,86	0,83	0,73	128	1487	450	2,8	192	5877	5879	6139
1.P...6560 Mb-8	1250	744	95,8	95,8	95,5	94,6	0,87	0,86	0,81	0,72	146	1636	453	2,8	206	6677	6887	7303
1.P...6630 Sa-8	1600																	
1.P...6630 Sb-8	1800																	
1.P...6630 Ma-8	2000																	
1.P...6630 Mb-8	2240																	
1.P...6710 Sa-8	2500																	
1.P...6710 Sb-8	2800																	
1.P...6710 Ma-8	3150																	
1.P...6710 Mb-8	3550																	

Note: All other motors frame sizes, executions and additional data are available on request; All quoted data are informal; Keeping back privilege for change in catalogue.

Technical data

28

HIGH VOLTAGE THREE PHASE
INDUCTION MOTORS WELDED
CONSTRUCTION

Type:
PR
PO
PW
PV

Protect.:
IPR 44
IP 23
IPW 24
IP 44

Cooling:
IC 31
IC 01
IC 01
IC 81W

Arrangement:
IM B3; (IM 1001)
IM V1; (IM 3011)

Execution:
Rotor: slip ring
Voltage: 6 kV
Frequency: 50 Hz
Insul. class: F

Type	Rated output P _N kW	Rated speed n min ⁻¹	Efficiency η %				Power factor cosφ				Rated current I _N A	Rotor		Max. torque M _{pr} /M _N	Mom. of inertia J _m kgm ²	Weight of motor		
			5/4 P _N	1/1P _N	3/4 P _N	1/2 P _N	5/4 P _N	1/1P _N	3/4 P _N	1/2 P _N		U ₂₀ V	I ₂₀ A			IPR 44	IPW24 IP 23	IP 44
ns=600 min ⁻¹																		
1.P...6400 Sb-10	200	589	91,2	91,7	91,6	90,2	0,72	0,7	0,63	0,52	30	370	349	1,9	21,6	2450	2460	2630
1.P...6400 Ma-10	225	589	91,5	92,2	92	90,8	0,75	0,72	0,67	0,55	33	404	359	1,9	23,9	2640	2650	2820
1.P...6400 Mb-10	250	589	91,9	92,3	92,2	90,9	0,75	0,72	0,67	0,54	37	444	361	2	25,9	2760	2770	2940
1.P...6450 Sa-10	280	589	91,9	92,2	92,1	91	0,78	0,74	0,68	0,56	40	617	279	2,1	43,3	3130	3140	3320
1.P...6450 Sb-10	315	589	92,1	92,6	92,5	91,5	0,78	0,75	0,69	0,58	44	677	289	2,1	48,3	3290	3300	3480
1.P...6450 Ma-10	355	589	92,2	92,6	92,6	91,7	0,78	0,76	0,71	0,6	49	740	298	2,1	51,8	3560	3570	3720
1.P...6450 Mb-10	400	589	92,3	92,7	92,6	91,8	0,78	0,76	0,71	0,6	55	814	305	2,1	56,8	3720	3735	3915
1.P...6500 Sa-10	450	592	94,1	94,1	93,8	92,5	0,82	0,8	0,75	0,63	58	960	284	2,4	93	3976	4128	4388
1.P...6500 Sb-10	500	592	94,2	94,3	94,1	92,9	0,82	0,81	0,76	0,66	63	1019	297	2,5	101,4	4226	4378	4638
1.P...6500 Ma-10	550	592	94,3	94,5	94,2	93,5	0,82	0,81	0,77	0,67	69	1084	307	2,4	110	4922	5054	5408
1.P...6500 Mb-10	630	593	94,4	94,5	94,1	93	0,82	0,8	0,74	0,63	80	1254	303	2,5	118	5233	5345	5719
1.P...6560 Sa-10	710	593	94,5	94,8	94,7	93,7	0,83	0,81	0,75	0,64	89	1212	355	2,2	162	5647	5753	6169
1.P...6560 Sb-10	800	593	94,6	94,8	94,7	93,8	0,83	0,82	0,78	0,69	99	1312	375	2,2	176	6196	6302	6718
1.P...6560 Ma-10	900	593	94,5	94,8	94,7	93,8	0,83	0,82	0,78	0,69	111	1430	387	2,2	189	6330	6540	6956
1.P...6560 Mb-10	1000	593	95	95,2	95	94,1	0,83	0,82	0,78	0,69	123	1574	389	2,2	203	6955	7165	7581
1.P...6630 Sa-10	1250																	
1.P...6630 Sb-10	1400																	
1.P...6630 Ma-10	1600																	
1.P...6710 Sa-10	1800																	
1.P...6710 Sb-10	2000																	
1.P...6710 Ma-10	2240																	
1.P...6710 Mb-10	2500																	

Note: All other motors frame sizes, executions and additional data are available on request; All quoted data are informal; Keeping back privilege for change in catalogue.

Technical data

HIGH VOLTAGE THREE PHASE
INDUCTION MOTORS WELDED
CONSTRUCTION

Type:
PR
PO
PW
PV

Protect.:
IPR 44
IP 23
IPW 24
IP 44

Cooling:
IC 31
IC 01
IC 01
IC 81W

Arrangement:
IM B3; (IM 1001)
IM V1; (IM 3011)

Execution:
Rotor: slip ring
Voltage: 6 kV
Frequency: 50 Hz
Insul. class: F

29

Type	Rated output P _N kW	Rated speed n min ⁻¹	Efficiency η %				Power factor cosφ				Rated current I _N A	Rotor voltage U ₂₀ V	Rotor current I ₂₀ A	Max. torque M _{pr} /M _N	Mom. of inertia J _m kgm ²	Weight of motor		
			5/4 P _N	1/1 P _N	3/4 P _N	1/2 P _N	5/4 P _N	1/1 P _N	3/4 P _N	1/2 P _N						IPR 44	IPW24 IP 23	IP 44
																m	kg	kg
ns=500 min ⁻¹																		
1.P...6450 Sa-12	225	489	90,9	91,2	91	89,5	0,72	0,69	0,62	0,5	34	488	285	2,3	50	3420	3430	3610
1.P...6450 Sb-12	250	489	91,9	91,4	91,1	89,5	0,72	0,69	0,62	0,5	38	554	278	2,3	55,7	3540	3550	3730
1.P...6450 Ma-12	280	490	91,5	91,6	91,2	89,5	0,72	0,69	0,62	0,5	43	639	268	2,3	63,8	3719	3729	3909
1.P...6450 Mb-12	315	490	91,6	91,8	91,4	89,9	0,73	0,69	0,62	0,5	48	693	279	2,3	61,5	3824	3834	4034
1.P...6500 Sa-12	355	492	93,3	93,5	93,2	91,8	0,78	0,75	0,69	0,58	49	900	243	2,4	87	4060	4212	4472
1.P...6500 Sb-12	400	492	93,3	93,4	93,1	91,6	0,77	0,74	0,68	0,56	56	1015	243	2,4	94	4372	4524	4784
1.P...6500 Ma-12	450	492	93,3	93,3	92,9	91,4	0,79	0,76	0,7	0,58	61	1160	240	2,4	114	5098	5210	5584
1.P...6500 Mb-12	500	492	93,6	93,8	93,5	92,2	0,79	0,76	0,71	0,59	67,5	1250	245	2,4	123	5306	5418	5792
1.P...6560 Sa-12	560	496	94	93,6	92,7	90,5	0,75	0,7	0,62	0,49	82	1425	238	3,1	220	5588	5664	6080
1.P...6560 Sb-12	630	495	94,1	93,8	93	91	0,77	0,7	0,66	0,53	88	1567	243	3	251	6165	6271	6687
1.P...6560 Ma-12	710	496	94,2	93,9	93,1	91	0,77	0,73	0,66	0,53	99	1742	246	3	277	6243	6453	6869
1.P...6560 Mb-12	800	496	94,5	94,1	93,3	91,3	0,77	0,73	0,66	0,53	112	1960	246	3	307	6945	7153	7571
1.P...6630 Sa-12	1000																	
1.P...6630 Sb-12	1120																	
1.P...6630 Ma-12	1250																	
1.P...6710 Sa-12	1400																	
1.P...6710 Sb-12	1600																	
1.P...6710 Ma-12	1800																	
1.P...6710 Mb-12	2000																	

Note: All other motors frame sizes, executions and additional data are available on request; All quoted data are informal; Keeping back privilege for change in catalogue.

Technical data

HIGH VOLTAGE THREE PHASE
INDUCTION MOTORS WELDED
CONSTRUCTION

Type:
PZ

Protect.:
IP 44

Cooling:
IC 611

Arrangement:
IM B3; (IM 1001)
IM V1; (IM 3001)

Execution:
Rotor: slip ring
Voltage: 6 kV
Frequency: 50 Hz
Insul. class: F

30

Type	Rated output P _N kW	Rated speed n min ⁻¹	Efficiency η %				Power factor cosφ				Rated current I _N A	Rotor		Max. torque M _{pk} /M _N	Mom. of inertia J _m kgm ²	Weight of motor IR 44 m kg
			5/4 P _N	1/1P _N	3/4 P _N	1/2 P _N	5/4 P _N	1/1P _N	3/4 P _N	1/2 P _N		voltage U ₂₀ V	current I ₂₀ A			
ns=1500 min ⁻¹																
1.PZ...6355 Sc-4	200	1483	90,9	91	90,6	89,2	0,87	0,87	0,84	0,77	24	385	320	2,4	7,1	2085
1.PZ...6355 Ma-4	225	1483	91,3	91,4	91	89,5	0,87	0,87	0,84	0,76	27	430	321	2,4	8,1	2190
1.PZ...6355 Mb-4	250	1483	91,3	91,4	91	89,7	0,87	0,87	0,85	0,77	30	457	336	2,2	8,6	2300
1.PZ...6355 Mc-4	280	1483	91,6	91,8	91,5	90,2	0,87	0,87	0,85	0,79	34	488	353	2,6	9,1	2346
1.PZ...6355 Md-4	315	1483	92,1	91,5	91,2	89,3	0,87	0,87	0,86	0,80	38	524	370	2,5	9,6	2410
1.PZ...6400 Sa-4	355	1486	93,8	94	93,6	92,4	0,85	0,84	0,81	0,73	43	503	434	2,2	14,1	2790
1.PZ...6400 Sb-4	400	1486	94,1	94,2	93,9	92,7	0,85	0,84	0,81	0,73	49	542	453	2,2	14,6	2850
1.PZ...6400 Ma-4	450	1486	94,3	94,4	94,1	92,8	0,86	0,85	0,83	0,75	54	615	447	2,3	16,4	3180
1.PZ...6400 Mb-4	500	1486	94,5	94,6	94,2	93	0,87	0,86	0,83	0,76	59	675	451	2,3	17,9	3300
1.PZ...6450 Sa-4	560	1483	92,9	92,9	92,5	91,3	0,87	0,87	0,85	0,79	67	700	489	2,4	31,9	3840
1.PZ...6450 Sb-4	630	1484	93,1	93,1	92,7	91,5	0,88	0,87	0,85	0,8	75	776	493	2,4	33,1	4030
1.PZ...6450 Ma-4	710	1485	93,2	93,2	92,8	91,6	0,88	0,87	0,85	0,78	84	875	491	2,5	37,3	4330
1.PZ...6450 Mb-4	800	1486	93,4	93,3	92,9	92	0,88	0,87	0,85	0,78	95	999	482	2,5	41	4530
1.PZ...6500 Sa-4	900	1487	94,8	94,8	94,4	93	0,91	0,9	0,89	0,84	100	1082	505	2,6	52	5400
1.PZ...6500 Sb-4	1000	1487	95	95	94,5	93	0,91	0,91	0,9	0,86	110	1173	517	2,5	59	5800
1.PZ...6500 Ma-4	1120	1487	95,2	95,1	94,7	93,5	0,92	0,92	0,91	0,88	122	1278	529	2,5	65	6200
1.PZ...6500 Mb-4	1250	1488	95,3	95,3	94,9	93,7	0,92	0,92	0,91	0,88	136	1406	535	2,6	72	6400
1.PZ...6560 Sa-4	1400	1485	95,4	95,5	95,4	94,5	0,9	0,91	0,9	0,87	154	1278	668	2,2	65	6234
1.PZ...6560 Sb-4	1600	1485	95,5	95,7	95,5	94,7	0,91	0,91	0,91	0,89	174	1406	693	2,2	74	6792
1.PZ...6560 Ma-4	1800	1486	95,7	95,8	95,6	94,8	0,91	0,92	0,91	0,89	195	1562	698	2,3	90	7042
1.PZ...6560 Mb-4	2000	1487	95,8	95,9	95,7	94,9	0,92	0,92	0,92	0,9	215	1758	687	2,4	98	7675
1.PZ...6630 Sa-4	2500															
1.PZ...6630 Sb-4	2800															
1.PZ...6630 Ma-4	3150															
1.PZ...6710 Sa-4	3550															
1.PZ...6710 Sb-4	4000															
1.PZ...6710 Ma-4	4500															
1.PZ...6710 Mb-4	5000															

Note: All other motors frame sizes, executions and additional data are available on request; All quoted data are informal; Keeping back privilege for change in catalogue.

Technical data

HIGH VOLTAGE THREE PHASE
INDUCTION MOTORS WELDED
CONSTRUCTION

Type:
PZ

Protect.:
IP 44

Cooling:
IC 611

Arrangement:
IM B3; (IM 1001)
IM V1; (IM 3011)

Execution:
Rotor: slip ring
Voltage: 6 kV
Frequency: 50 Hz
Insul. class: F

31

Type	Rated output P_N kW	Rated speed n min^{-1}	Efficiency η %				Power factor $\cos\phi$				Rated current I_N A	Rotor		Max. torque M_{PR}/M_N	Mom. of inertia J_m kgm^2	Weight of motor IR 44 m kg
			5/4 P_N	1/1 P_N	3/4 P_N	1/2 P_N	5/4 P_N	1/1 P_N	3/4 P_N	1/2 P_N		voltage U_{20} V	current I_{20} A			
$n_s=1000 \text{ min}^{-1}$																
1.PZ...6355 Mb-6	200	991	93,3	93,3	92,9	91,4	0,84	0,83	0,8	0,71	25	464	318	2,2	14,6	2430
1.PZ...6400 Sa-6	225	988	93,3	93,4	93,2	92	0,83	0,82	0,77	0,67	28	434	317	2,3	15,6	2640
1.PZ...6400 Sb-6	250	987	93,1	93,4	93,3	92,2	0,84	0,83	0,79	0,69	31	448	343	2,3	15,9	2730
1.PZ...6400 Sc-6	280	988	93,2	93,5	93,4	92,4	0,85	0,84	0,8	0,72	34	496	346	2,3	17,6	2850
1.PZ...6400 Sd-6	315	988	93,8	94	93,8	92,8	0,85	0,84	0,81	0,72	38	555	347	2,3	19,3	2970
1.PZ...6400 Ma-6	355	989	94,1	94,2	93,9	92,9	0,85	0,84	0,81	0,72	43	628	344	2,3	21,8	3270
1.PZ...6400 Mb-6	400	989	94,2	94,3	94,1	93,1	0,86	0,85	0,82	0,74	48	690	354	2,3	23,9	3390
1.PZ...6450 Sa-6	450	989	92,8	92,8	92,4	91,1	0,83	0,82	0,77	0,67	57	746	369	2,3	41	3560
1.PZ...6450 Sb-6	500	989	92,9	92,9	92,5	91,5	0,84	0,82	0,78	0,69	63	829	367	2,3	44,8	3750
1.PZ...6450 Ma-6	560	990	93,2	93	92,7	93,2	0,85	0,82	0,79	0,69	71	933	364	2,3	50	4050
1.PZ...6450 Mb-6	630	990	93,3	93,1	93,2	91,3	0,85	0,82	0,79	0,69	79	1066	357	2,3	54,5	4190
1.PZ...6500 Sa-6	710	992	95,2	95,1	94,7	93,4	0,89	0,88	0,86	0,79	80	1125	379	2,8	87	5400
1.PZ...6500 Sb-6	800	992	95,3	95,3	94,9	93,6	0,89	0,89	0,86	0,8	90	1220	395	2,8	95	5800
1.PZ...6500 Ma-6	900	992	95,5	95,4	95	93,8	0,89	0,89	0,87	0,8	101	1330	406	2,8	103	6200
1.PZ...6500 Mb-6	1000	992	95,6	95,5	95,1	94	0,89	0,89	0,86	0,79	112	1463	409	2,9	111	6400
1.PZ...6560 Sa-6	1120	991	95,4	95,5	95,3	94,5	0,89	0,89	0,88	0,84	126,8	1220	560	2,1	110	6594
1.PZ...6560 Sb-6	1250	991	95,5	95,6	95,4	94,6	0,89	0,89	0,88	0,84	141,4	1330	573	2,1	120	7134
1.PZ...6560 Ma-6	1400	991	95,6	95,7	95,5	94,7	0,89	0,89	0,88	0,83	157,8	1463	582	2,2	130	7628
1.PZ...6560 Mb-6	1600	992	95,9	95,9	95,6	94,6	0,89	0,89	0,88	0,82	180,4	1830	527	2,4	162	8299
1.PZ...6630 Sa-6	2000															
1.PZ...6630 Sb-6	2240															
1.PZ...6630 Ma-6	2500															
1.PZ...6710 Sa-6	2800															
1.PZ...6710 Sb-6	3150															
1.PZ...6710 Ma-6	3550															

Note: All other motors frame sizes, executions and additional data are available on request; All quoted data are informal; Keeping back privilege for change in catalogue.

Technical data

32

HIGH VOLTAGE THREE PHASE
INDUCTION MOTORS WELDED
CONSTRUCTION

Type:
PZ

Protect.:
IP 44

Cooling:
IC 611

Arrangement:
IM B3; (IM 1001)
IM V1; (IM 3001)

Execution:
Rotor: slip ring
Voltage: 6 kV
Frequency: 50 Hz
Insul. class: F

Type	Rated output P _N kW	Rated speed n min ⁻¹	Efficiency η %				Power factor cosφ				Rated current I _N A	Rotor		Max. torque M _{pk} /M _N	Mom. of inertia J _m kgm ²	Weight of motor IR 44 m kg
			5/4 P _N	1/1 P _N	3/4 P _N	1/2 P _N	5/4 P _N	1/1 P _N	3/4 P _N	1/2 P _N		U ₂₀ V	I ₂₀ A			
ns=750 min ⁻¹																
1.PZ...6400 Sa-8	180	740	92	92,1	91,6	89,9	0,83	0,78	0,7	0,6	24	424	260	2,3	18,1	2710
1.PZ...6400 Sb-8	200	739	92,3	92,5	92,2	90,1	0,83	0,8	0,7	0,6	26	450	274	2,3	20,1	2850
1.PZ...6400 Ma-8	225	739	92,4	92,6	92,3	90,8	0,83	0,8	0,7	0,6	29	490	2814	2,3	21,4	3180
1.PZ...6400 Mb-8	250	739	92,7	92,9	92,6	91,3	0,83	0,8	0,8	0,73	32	541	283	2,3	23,9	3210
1.PZ...6450 Sa-8	280	742	92,6	92,4	91,7	89,9	0,78	0,75	0,68	0,56	39	575	294	2,2	35,3	3637
1.PZ...6450 Sb-8	315	742	92,7	92,5	91,7	90,2	0,78	0,75	0,68	0,56	44	620	308	2,2	37,3	3760
1.PZ...6450 Sc-8	355	742	92,9	92,8	92,2	90,6	0,79	0,76	0,7	0,58	48	672	319	2,2	39,3	3900
1.PZ...6450 Ma-8	400	742	93	92,9	92,4	90,8	0,8	0,77	0,71	0,58	54	733	330	2,2	41,8	4140
1.PZ...6450 Mb-8	450	742	93,3	93,2	92,7	91,2	0,8	0,78	0,72	0,6	60	809	336	2,2	45,8	4270
1.PZ...6450 Mc-8	500	742	93,3	93,2	92,7	91,2	0,81	0,78	0,72	0,6	66	899	335	2,3	48,8	4410
1.PZ...6500 Sa-8	560	741	94,2	94,1	93,7	92,2	0,86	0,86	0,83	0,76	66	642	529	2,3	83	5600
1.PZ...6500 Sb-8	630	742	94,3	94,2	93,7	92,2	0,87	0,86	0,83	0,76	74	750	508	2,4	98	5800
1.PZ...6500 Ma-8	710	743	94,4	94,3	93,7	92	0,87	0,86	0,84	0,76	83	898	475	2,5	121	6200
1.PZ...6500 Mb-8	800	743	94,5	94,4	93,8	92,1	0,87	0,87	0,84	0,77	93	999	481	2,5	137	6400
1.PZ...6560 Ma-8	900	743	95,1	95	94,7	93,4	0,88	0,87	0,85	0,77	104	1364	403	2,8	192	6300
1.PZ...6560 Mb-8	1000	744	95,3	95,2	94,7	93,4	0,87	0,86	0,82	0,74	116	1488	408	2,8	206	7600
1.PZ...6630 Sa-8	1400															
1.PZ...6630 Sb-8	1600															
1.PZ...6630 Ma-8	1800															
1.PZ...6630 Mb-8	2000															
1.PZ...6710 Sa-8	2240															
1.PZ...6710 Sb-8	2500															
1.PZ...6710 Ma-8	2800															
1.PZ...6710 Mb-8	3150															

Note: All other motors frame sizes, executions and additional data are available on request; All quoted data are informal; Keeping back privilege for change in catalogue.

Technical data

HIGH VOLTAGE THREE PHASE
INDUCTION MOTORS WELDED
CONSTRUCTION

Type:
PZ

Protect.:
IP 44

Cooling:
IC 611

Arrangement:
IM B3; (IM 1001)
IM V1; (IM 3011)

Execution:
Rotor: slip ring
Voltage: 6 kV
Frequency: 50 Hz
Insul. class: F

33

Type	Rated output	Rated speed	Efficiency η %				Power factor $\cos\phi$				Rated current I_N	Rotor		Max. torque M_{PR}/M_N	Mom. of inertia J_m kgm^2	Weight of motor IR 44 m kg
	P_N	n	$5/4 P_N$	$1/1 P_N$	$3/4 P_N$	$1/2 P_N$	$5/4 P_N$	$1/1 P_N$	$3/4 P_N$	$1/2 P_N$		U_{20}	I_{20}			
	kW	min^{-1}														
ns=600 min^{-1}																
1.PZ...6400 Sb-10	160	591	91,5	91,4	90,6	88,4	0,73	0,68	0,60	0,48	25	370	274	2,3	23,1	2810
1.PZ...6400 Ma-10	180	591	91,8	91,8	91,2	89,1	0,74	0,7	0,63	0,5	27	404	282	2,3	25,4	3000
1.PZ...6400 Mb-10	200	591	92,1	92	91,3	89,2	0,75	0,7	0,62	0,41	30	444	284	2,3	27,4	3120
1.PZ...6450 Sa-10	225	592	92,3	92,2	91,5	89,6	0,76	0,71	0,64	0,52	33	617	222	2,3	46,3	3450
1.PZ...6450 Sb-10	250	592	92,6	92,5	91,9	90,1	0,76	0,71	0,66	0,53	37	677	227	2,3	51,3	3610
1.PZ...6450 Ma-10	280	592	92,8	92,9	92,2	90,4	0,78	0,74	0,67	0,53	39	740	232	2,3	54,8	3860
1.PZ...6450 Mb-10	315	592	92,9	92,9	92,3	90,6	0,78	0,74	0,67	0,55	44	812	237	2,3	59,8	4025
1.PZ...6500 Sa-10	355	592	93,7	93,7	93,2	91,6	0,84	0,82	0,77	0,67	45	858	251	2,5	93	4388
1.PZ...6500 Sb-10	400	593	93,8	93,8	93,3	91,7	0,84	0,82	0,76	0,66	50	960	252	2,6	101	4638
1.PZ...6500 Ma-10	450	592	94	94	93,5	92,1	0,85	0,83	0,78	0,68	56	1019	268	2,5	110	5408
1.PZ...6500 Mb-10	500	592	94,1	94,1	93,7	92,4	0,85	0,83	0,79	0,7	62	1087	279	2,3	118	5719
1.PZ...6560 Sa-10	560	594	94,1	94,1	93,7	92,2	0,83	0,82	0,77	0,68	69	1124	306	2,4	162	6377
1.PZ...6560 Sb-10	630	594	94,2	94,3	93,9	92,5	0,83	0,82	0,78	0,69	77	1210	320	2,3	176	6926
1.PZ...6560 Ma-10	710	594	94,4	94,4	94,1	92,7	0,83	0,83	0,79	0,7	88	1312	362	2,2	190	7216
1.PZ...6560 Mb-10	800	594	94,5	94,6	94,2	93	0,84	0,83	0,79	0,7	98	1432	343	2,2	203	7845
1.PZ...6630 Sa-10	1120															
1.PZ...6630 Sb-10	1250															
1.PZ...6630 Ma-10	1400															
1.PZ...6710 Sa-10	1600															
1.PZ...6710 Sb-10	1800															
1.PZ...6710 Ma-10	2000															
1.PZ...6710 Mb-10	2240															

Note: All other motors frame sizes, executions and additional data are available on request; All quoted data are informal; Keeping back privilege for change in catalogue.

Technical data

34

HIGH VOLTAGE THREE PHASE
INDUCTION MOTORS WELDED
CONSTRUCTION

Type:
PZ

Protect.:
IP 44

Cooling:
IC 611

Arrangement:
IM B3; (IM 1001)
IM V1; (IM 3001)

Execution:
Rotor: slip ring
Voltage: 6 kV
Frequency: 50 Hz
Insul. class: F

Type	Rated output P _N kW	Rated speed n min ⁻¹	Efficiency η %				Power factor cosφ				Rated current I _N A	Rotor		Max. torque M _{pk} /M _N	Mom. of inertia J _m kgm ²	Weight of motor IR 44 m kg
			5/4 P _N	1/1P _N	3/4 P _N	1/2 P _N	5/4 P _N	1/1P _N	3/4 P _N	1/2 P _N		voltage U ₂₀ V	current I ₂₀ A			
ns=500 min ⁻¹																
1.PZ...6450 Sa-12	180	490	91,2	91	90,1	87,7	0,76	0,7	0,63	0,5	27	489	226	2,5	51	3740
1.PZ...6450 Sb-12	200	490	91,3	91,1	90,1	87,6	0,75	0,7	0,62	0,49	31	554	221	2,5	56,7	3860
1.PZ...6450 Ma-12	225	490	91,5	91,2	90,2	87,6	0,75	0,7	0,61	0,48	34	639	214	2,5	64,8	4015
1.PZ...6450 Mb-12	250	490	91,7	91,4	90,4	88	0,76	0,7	0,62	0,49	38	692	220	2,5	62,5	4144
1.PZ...6500 Sa-12	280	492	92,9	93	92,6	91	0,8	0,78	0,73	0,61	37	810	217	2,4	87	4472
1.PZ...6500 Sb-12	315	492	93,1	93,2	92,7	91,1	0,8	0,77	0,72	0,61	42	900	215	2,4	96	4784
1.PZ...6500 Ma-12	355	493	93,2	93,2	92,5	90,7	0,79	0,76	0,7	0,58	48	1080	200	2,4	114	5584
1.PZ...6500 Mb-12	400	493	93,4	93,3	92,8	91,1	0,8	0,77	0,71	0,6	54	1160	210	2,4	123	5792
1.PZ...6560 Sa-12	450	496	93,5	93	91,9	89	0,78	0,74	0,67	0,54	62	1305	208	3,2	220	6288
1.PZ...6560 Sb-12	500	496	93,7	93,2	92,2	89,7	0,8	0,76	0,69	0,58	67	1425	212	3,1	256	6895
1.PZ...6560 Ma-12	560	496	93,8	93,4	92,3	89,9	0,8	0,77	0,71	0,59	74	1576	215	3,1	276	7129
1.PZ...6560 Mb-12	630	496	93,9	93,5	92,5	90,2	0,81	0,78	0,72	0,6	83	1742	218	3,1	308	7831
1.PZ...6630 Sa-12	800															
1.PZ...6630 Sa-12	900															
1.PZ...6630 Ma-12	1000															
1.PZ...6630 Mb-12	1120															
1.PZ...6710 Sa-12	1250															
1.PZ...6710 Sb-12	1400															
1.PZ...6710 Sc-12	1600															

on request

on request

Note: All other motors frame sizes, executions and additional data are available on request; All quoted data are informal; Keeping back privilege for change in catalogue.

Dimensional sketches

HIGH VOLTAGE THREE PHASE
INDUCTION MOTORS WELDED
CONSTRUCTION

Rotor: squirrel cage

Execution: KR

Arrangement: IM B3 (IM 1001)
Protect.: IPR 54 (IPR55)
Cooling method: IC 31

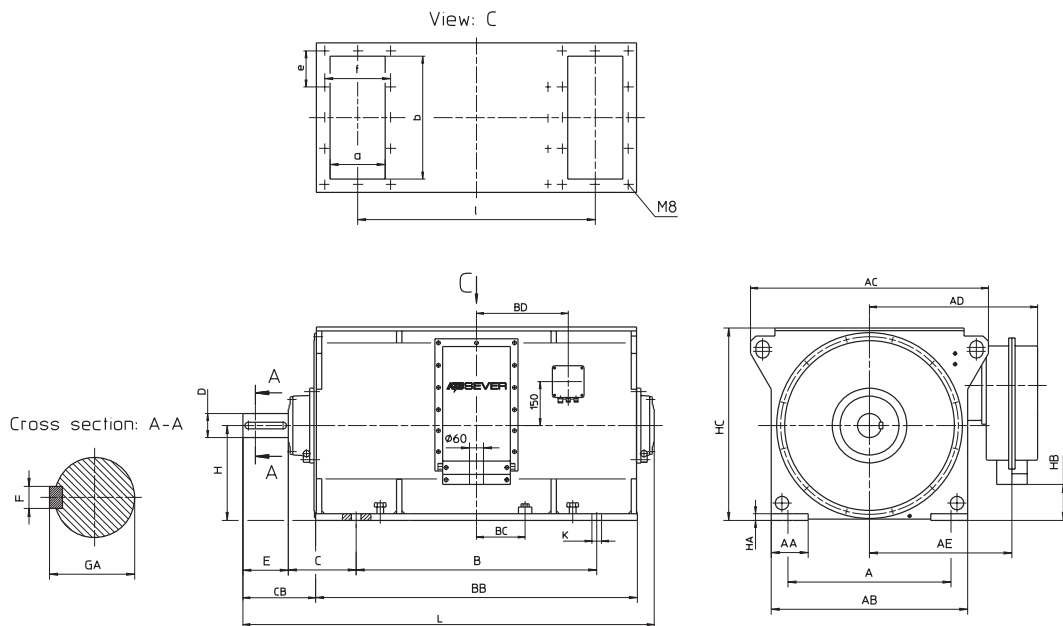

¹⁾ If request cable inlet can be delivered in range $\phi 60 - \phi 80$, or with two inlet holes $\phi 50 - \phi 70$.

Frame	2p	a	b	n x e	f	l	HC
355	S $\frac{2}{4-6}$	240	550	4 x 145	270	778	720
	M $\frac{2}{4-6}$					878	
400	S $\frac{2}{4-10}$	260	650	4 x 170	290	862	820
	M $\frac{2}{4-10}$					962	
450	S $\frac{2}{4-12}$	260	750	5 x 156	290	1024	920
	M $\frac{2}{4-12}$					1144	

²⁾ All other dimensions according to execution KO (IM B3)
- Fixing dimensions obligatory, all other informal.

Dimensional sketches

HIGH VOLTAGE THREE PHASE
INDUCTION MOTORS WELDED
CONSTRUCTION

Rotor: squirrel cage

Execution: KR

Arrangement: IM B3 (IM 1001)
Protect.: IPR 54 (IPR55)
Cooling method: IC 31

36

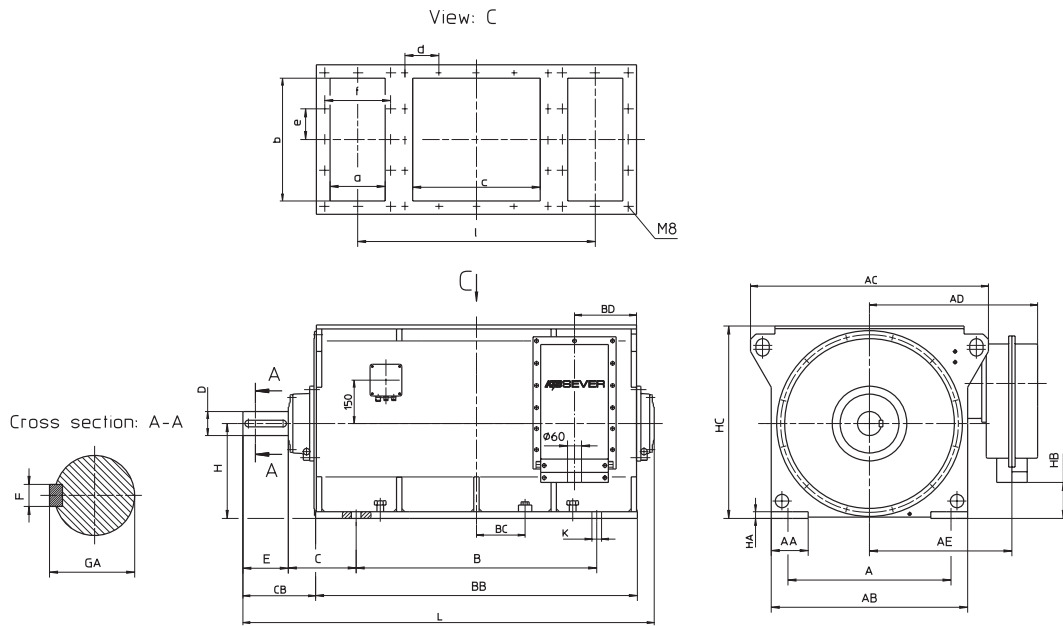

¹⁾ If request cable inlet can be delivered in range $\phi 60 - \phi 80$, or with two inlet holes $\phi 50 - \phi 70$.

Frame	2p	a	b	c	n x e	f	l	HC
500	S	4 - 12	300	800	4 x 210	330	1200	1010
	M							
560	S	4 - 12	260	860	4 x 225	340	1360	1120
	M							

²⁾ All other dimensions according to execution K0 (IM B3)
- Fixing dimensions obligatory, all other informal.

Dimensional sketches

HIGH VOLTAGE THREE PHASE
INDUCTION MOTORS WELDED
CONSTRUCTION

Rotor: squirrel cage

Execution: KRF*

Arrangement: IM V1 (IM 3011)
Protect.: IPR 54 (IPR55)
Cooling method: IC 01

37

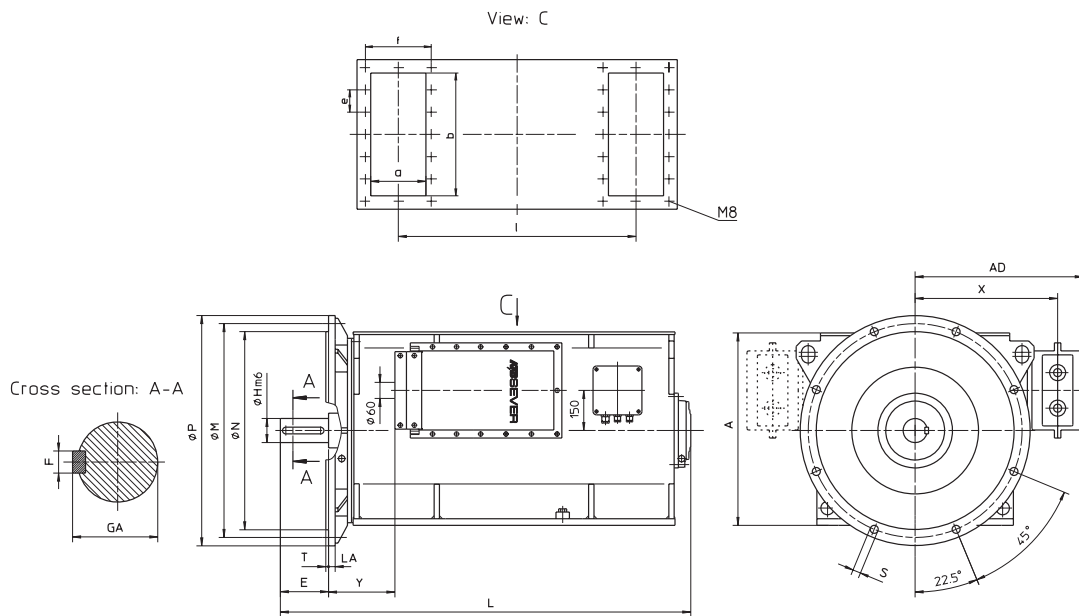

¹⁾ If request cable inlet can be delivered in range
 $\phi 60 - \phi 80$, or with two inlet holes $\phi 50 - \phi 70$.

Flange	Frame	2p	A	AD	D	E	F	GA	L	LA	M	N	P	S	T	C	Y	
FF 740	355	S	2	720	630	70	140	20	74,5	1406	28	740	680	800	24	6	510	210
		4 - 6	90			170	25	95	1445	260								
	M	2	70			140	20	74,5	1506	260								
	4 - 6	90	170			25	95	1545	260									
FF 940	400	S	2	820	680	75	140	20	79,5	1545	28	940	880	1000	28	6	560	285
		4 - 10	100			210	28	106	1635	355								
	M	2	75			140	20	79,5	1645	355								
	4 - 10	100	210			28	106	1735	355									
FF 1080	450	S	2	920	730	85	170	22	90	1745	28	1080	1000	1150	28	6	610	370
		4 - 12	110			210	28	116	1800	430								
	M	2	85			170	22	90	1865	430								
	4 - 12	110	210			28	116	1920	430									
FF 1180	500	S	4 - 12	1010	895	125	210	32	132	2000	28	1180	1120	1250	28	7	700	-
		M	4 - 12			125	210	32	132	2120								-
FF1320	560	S	4 - 12	1120	910	140	250	36	148	2320	28	1320	1250	1400	28	8	755	-
		M	4 - 12			140	250	36	148	2450								-

²⁾ * For every horizontal type [KR , KO , KW , ,PV i PZ] it is possible to produce vertical type [KRF , KOF , KWF , ,PVF i PZF].
- Fixing dimensions obligatory, all other informal.

- For shaft high 500 and 560, position of terminal boxes is change.

V

Note: All other motors frame sizes, executions and additional data are available on request; All quoted data are informal; Keeping back privilege for change in catalogue.

Dimensional sketches

HIGH VOLTAGE THREE PHASE
INDUCTION MOTORS WELDED
CONSTRUCTION

Rotor: squirrel cage

Execution: K0

Arrangement: IM B3 (IM 1001)
Protect.: IP 23
Cooling method: IC 01

38

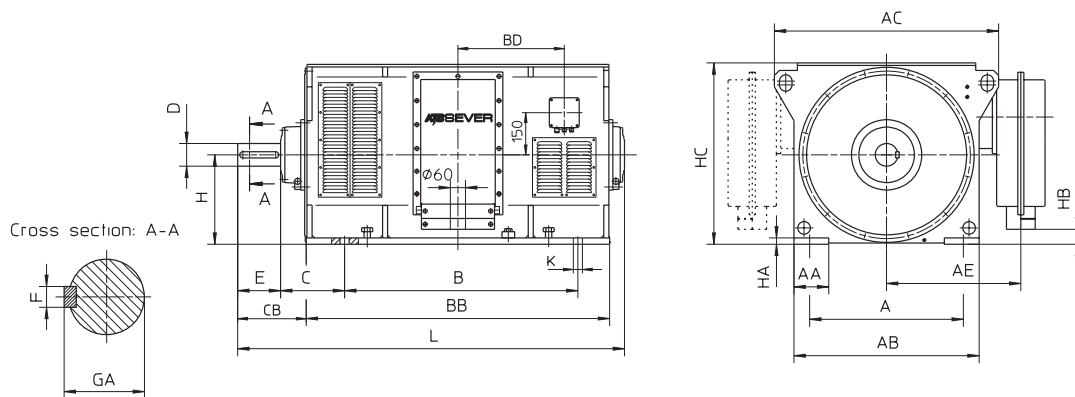

¹⁾ If request cable inlet can be delivered in range $\phi 60 - \phi 80$, or with two inlet holes $\phi 50 - \phi 70$.

Frame	2p	A	AA	AB	AC	AD	AE	B	BA	BB	BC	BD	C	CB	D	E	F	GA	H	HA	HB	HC	HD	K	L
355	S	2						800		1106	132			242	70	140	20	74,5							1406
		4-6	610	131	720	890	630		350			380	254	272	90	170	25	95	355	25	60	720	1253	36	1445
	M	2						900		1206	182			242	70	140	20	74,5							1506
400		4-6												272	90	170	25	95							1545
	S	2						900		1234	165			255	75	140	20	79,5							1545
		4-10	686	151	820	990	680	585		380		425	280	325	100	210	28	106	400	25	105	820	1353	36	1635
450	M	2						1000		1334	215			255	75	140	20	79,5							1645
		4-10												325	100	210	28	106							1735
	S	2						1000		1396	206			285	85	170	22	90							1745
450		4-12	750	181	920	1090	730	635		420		520	315	325	110	210	28	116	450	25	155	920	1453	42	1800
		2												285	85	170	22	90							1865
	M	4-12						1120		1516	266			325	110	210	28	116							1920

²⁾ All other dimensions according to execution K0 (IM B3)
- Fixing dimensions obligatory, all other informal.

Note: All other motors frame sizes, executions and additional data are available on request; All quoted data are informal; Keeping back privilege for change in catalogue.

Dimensional sketches

HIGH VOLTAGE THREE PHASE
INDUCTION MOTORS WELDED
CONSTRUCTION

Rotor: squirrel cage

Execution: KO

Arrangement: IM B3 (IM 1001)
Protect.: IP 23
Cooling method: IC 01

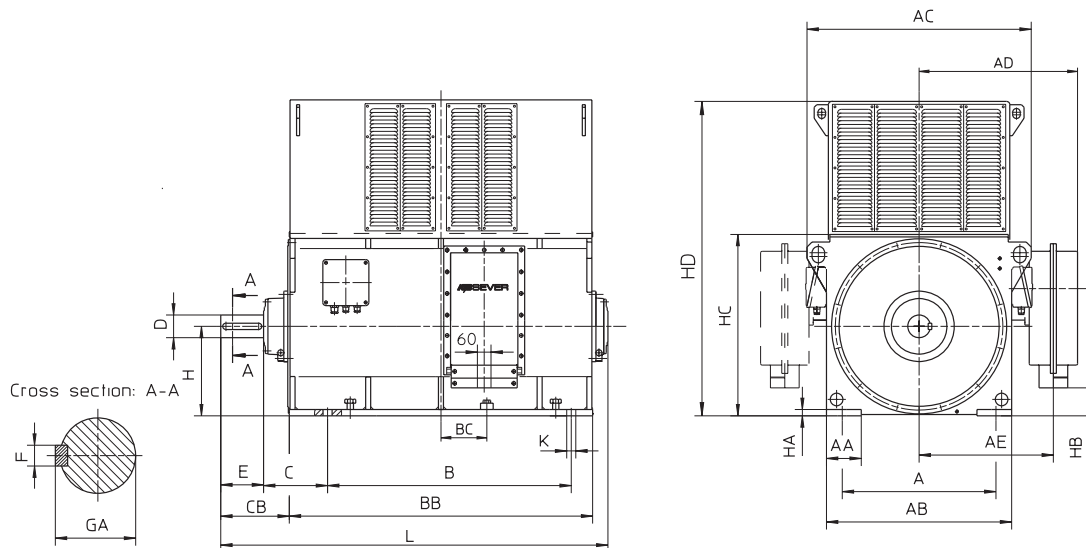

¹⁾ If request cable inlet can be delivered in range
 $\phi 60 - \phi 80$, or with two inlet holes $\phi 50 - \phi 70$.

Frame	2p	A	AA	AB	AC	AD	AE	B	BA	BB	BC	BD	C	CB	D	E	F	GA	H	HA	HB	HC	HD	K	L	
500	S	4 - 12	900	210	1050	1250	895	700	1000	600	1600	170	230	400	328	125	210	32	132	500	25	205	1010	1700	42	2000
	M										1120	1720														230
560	S	4 - 12	950	300	1160	1360	910	755	1120	600	1820	230	230	500	388	140	250	36	148	560	25	265	1120	1820	42	2320
	M										1250	1950														305

²⁾ All other dimensions according to execution KO (IM B3)
- Fixing dimensions obligatory, all other informal.

Dimensional sketches

HIGH VOLTAGE THREE PHASE
INDUCTION MOTORS WELDED
CONSTRUCTION

Rotor: squirrel cage

Execution: KZ

Arrangement: IM B3 (IM 1001)
Protect.: IP 54 (IP 55)
Cooling method: IC 611
Heat exchanger: air-air

40

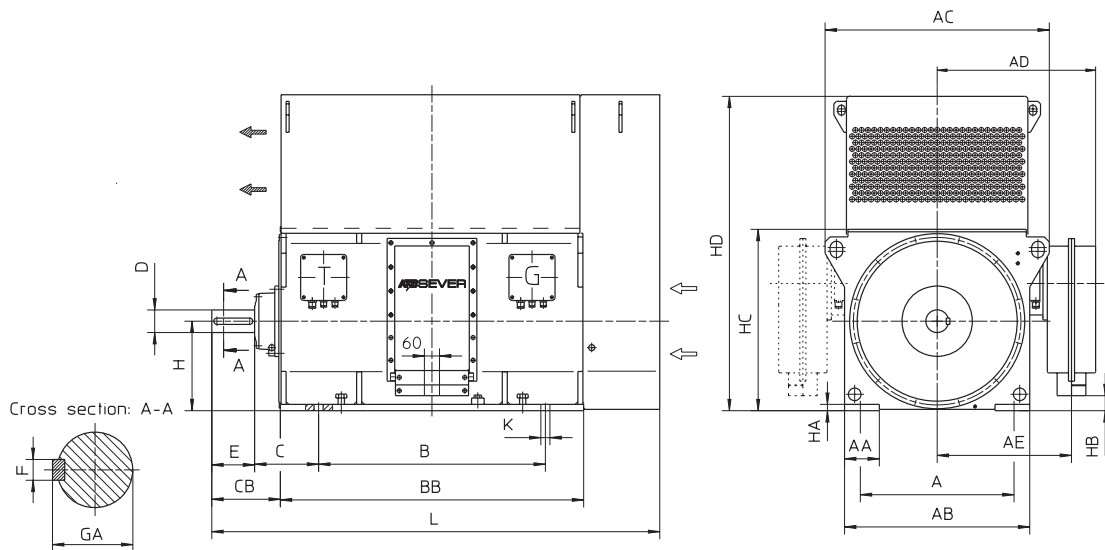

¹⁾ If request cable inlet can be delivered in range $\phi 60 - \phi 80$, or with two inlet holes $\phi 50 - \phi 70$.

Frame	2p	A	AA	AB	AC	AD	AE	B	BA	BB	BC	BD	C	CB	D	E	F	GA	H	HA	HB	HC	HD	K	L					
355	S	2	610	131	720	890	630	535	800	1106	132	380	254	242	70	140	20	74,5	355	25	60	720	1253	36	1650					
	4	272																								90	170	25	95	1680
	M	2																								242	70	140	20	75
		4 - 6						900		1206	182			272	90	170	25	95							1780					
400	S	2	686	151	820	990	680	585	900	1234	165	425	280	255	75	140	20	79,5	400	25	105	820	1353	36	1790					
	4 - 10	325																								100	210	28	106	1860
	M	2																								255	75	140	20	79,5
		4 - 10						1000		1334	215			325	100	210	28	106							1960					
450	S	2	750	181	920	1090	730	635	1000	1396	206	520	315	285	85	170	22	90	450	25	155	920	1453	42	1985					
	4 - 12	325																								110	210	28	116	2025
	M	2																								285	85	170	22	90
		4 - 12						1120		1516	266			325	110	210	28	116							2145					

²⁾ All other dimensions according to execution K0 (IM B3)
- Fixing dimensions obligatory, all other informal.

Note: All other motors frame sizes, executions and additional data are available on request; All quoted data are informal; Keeping back privilege for change in catalogue.

Dimensional sketches

HIGH VOLTAGE THREE PHASE
INDUCTION MOTORS WELDED
CONSTRUCTION

Rotor: squirrel cage

Execution: KZ

Arrangement: IM B3 (IM 1001)
Protect.: IP 54 (IP 55)
Cooling method: IC 611
Heat exchanger: air-air

41

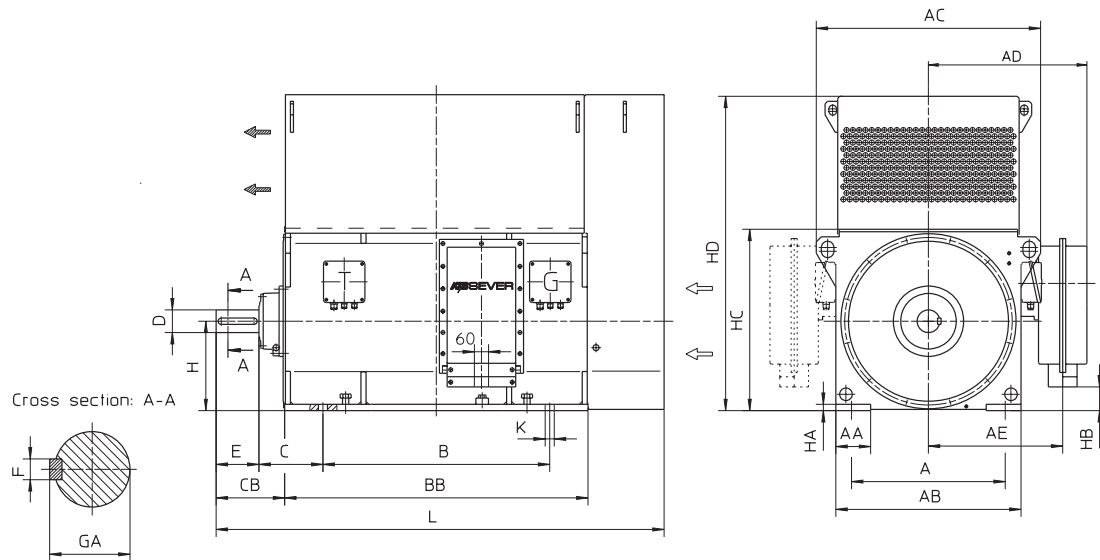

¹⁾ If request cable inlet can be delivered in range $\phi 60 - \phi 80$, or with two inlet holes $\phi 50 - \phi 70$.

Frame	2p	A	AA	AB	AC	AD	AE	B	BA	BB	BC	BD	C	CB	D	E	F	GA	H	HA	HB	HC	HD	K	L	
500	S	4 - 12	900	210	1050	1250	895	700	1000	600	1600	170	230	400	328	125	210	32	132	500	25	205	1010	1700	42	2280
	M										1120	230														2400
560	S	4 - 12	950	300	1160	1360	910	755	1120	600	1820	230	230	500	388	140	250	36	148	560	25	265	1120	1850	42	2520
	M										1250	305														2650

²⁾ All other dimensions according to execution K0 (IM B3)
- Fixing dimensions obligatory, all other informal.

Dimensional sketches

HIGH VOLTAGE THREE PHASE
INDUCTION MOTORS WELDED
CONSTRUCTION

Rotor: slip ring

Execution: PR

Arrangement: IM B3 (IM 1001)
Protect.: IPR 54 (IP 55)
Cooling method: IC 31

42

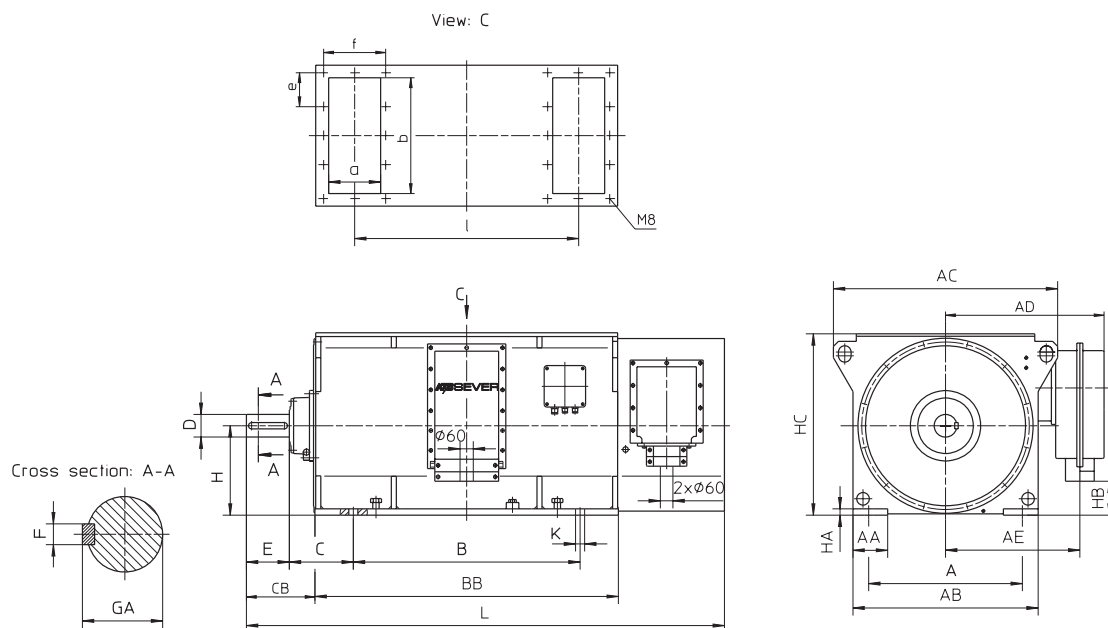

¹⁾ If request cable inlet can be delivered in range $\phi 60 - \phi 80$, or with two inlet holes $\phi 50 - \phi 70$.

Frame	2p	a	b	n x e	f	l	HC
355	S 2 4 - 6	240	550	4 x 145	270	778	720
	M 2 4 - 6					878	
400	S 2 4 - 10	260	650	4 x 170	290	862	820
	M 2 4 - 10					962	
450	S 2 4 - 12	260	750	5 x 156	290	1024	920
	M 2 4 - 12					1144	

²⁾ All other dimensions according to execution K0 (IM B3)
- Fixing dimensions obligatory, all other informal.

Note: All other motors frame sizes, executions and additional data are available on request; All quoted data are informal; Keeping back privilege for change in catalogue.

Dimensional sketches

HIGH VOLTAGE THREE PHASE
INDUCTION MOTORS WELDED
CONSTRUCTION

Rotor: slip ring

Execution: PR

Arrangement: IM B3 (IM 1001)
Protect.: IPR54 (IPR 55)
Cooling method: IC 31

43

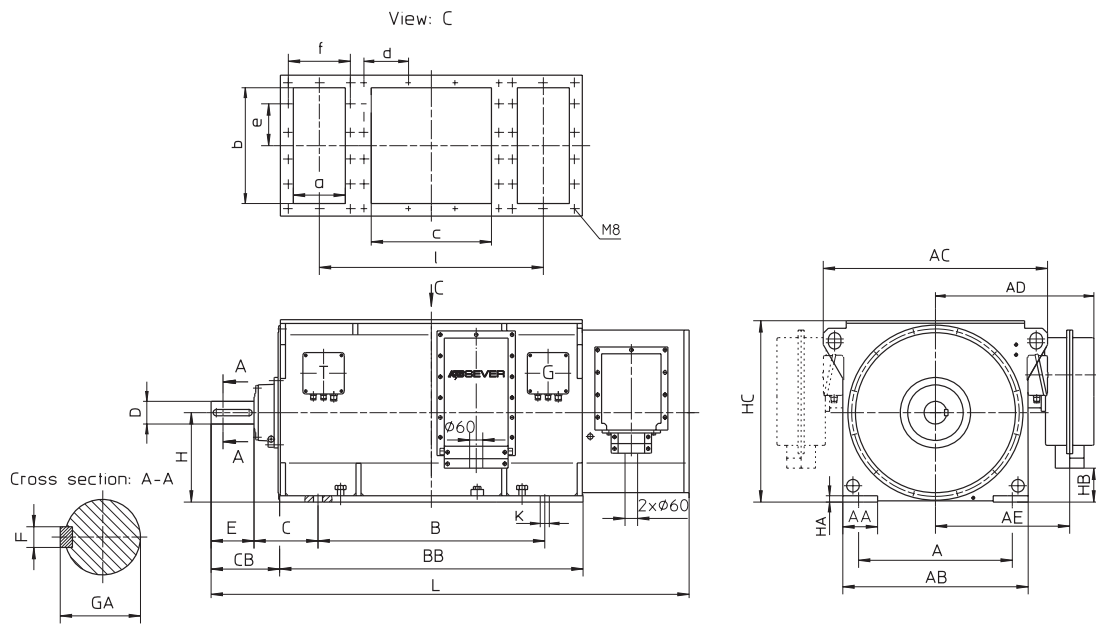

¹⁾ If request cable inlet can be delivered in range $\phi 60 - \phi 80$, or with two inlet holes $\phi 50 - \phi 70$.

Frame	2p	a	b	c	n x e	n x d	f	l	HC
500	S	4 - 12	300	800	4 x 210	3 x 210	330	1200	1010
	M					3 x 250		1320	
560	S	4 - 12	310	860	4 x 225	3 x 270	340	1360	1120
	M					3 x 315		1490	

²⁾ All other dimensions according to execution KO (IM B3)
- Fixing dimensions obligatory, all other informal.

Dimensional sketches

HIGH VOLTAGE THREE PHASE
INDUCTION MOTORS WELDED
CONSTRUCTION

Rotor: slip ring

Execution: PO

Arrangement: IM B3 (IM 1001)
Protect.: IP 44 (IP 55)
Cooling method: IC 611

44

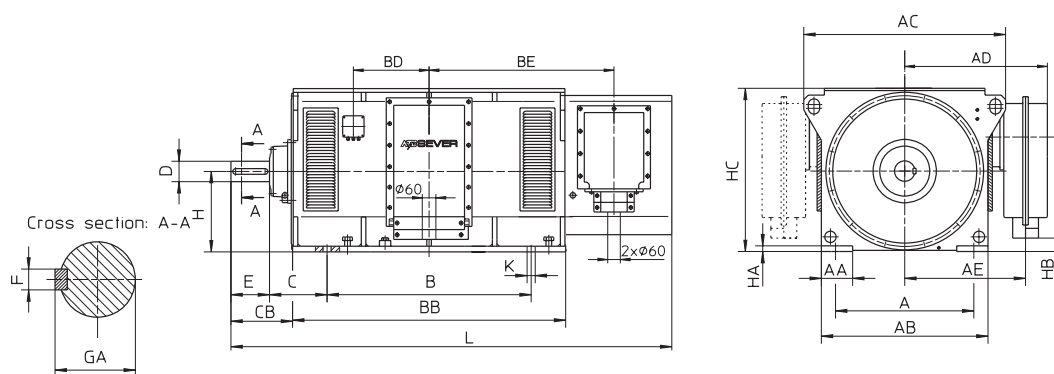

¹⁾ If request cable inlet can be delivered in range $\phi 60 - \phi 80$, or with two inlet holes $\phi 50 - \phi 70$.

Frame	2p	A	AA	AB	AC	AD	AE	B	BA	BB	BC	BD	BE	C	CB	D	E	F	GA	H	HA	HB	HC	HD	K	L
355	S 4 - 6	610	131	720	890	630	535	800	350	1106	132	380	744	254	272	90	170	25	95	355	25	60	720	1250	36	1830
	900							1206		182	794		1930													
400	S 4 - 10	686	151	820	990	680	585	900	380	1234	165	425	807	280	325	100	210	28	106	400	25	105	820	1350	36	2010
	1000							1334		215	857		2110													
450	S 4 - 12	750	181	920	1090	730	635	1000	420	1396	206	520	888	315	325	110	210	28	116	450	25	155	920	1450	42	2175
	1120							1516		266	948		2295													

²⁾ All other dimensions according to execution K0 (IM B3)
- Fixing dimensions obligatory, all other informal.

Note: All other motors frame sizes, executions and additional data are available on request; All quoted data are informal; Keeping back privilege for change in catalogue.

Dimensional sketches

HIGH VOLTAGE THREE PHASE
INDUCTION MOTORS WELDED
CONSTRUCTION

Rotor: slip ring

Execution: P0

Arrangement: IM B3 (IM 1001)
Protect.: IP 23
Cooling method: IC 01

45

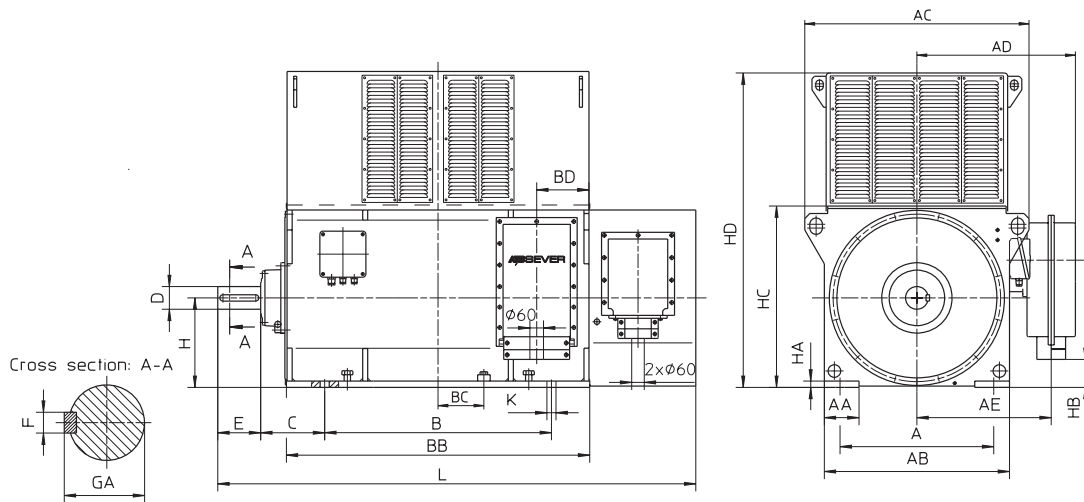

¹⁾ If request cable inlet can be delivered in range
 $\phi 60 - \phi 80$, or with two inlet holes $\phi 50 - \phi 70$.

Frame	2p	A	AA	AB	AC	AD	AE	B	BA	BB	BC	BD	BE	C	CB	D	E	F	GA	H	HA	HB	HC	HD	K	L
500	S	4 - 12	900	210	1050	1250	895	700	1000	1600	170	230	470	400	328	125	210	32	132	500	25	205	1010	1700	42	2480
	M								1120	1720	230															2600
560	S	4 - 12	950	300	1160	1360	910	755	1120	1820	230	230	470	500	388	140	250	36	148	560	25	265	1120	1850	42	2800
	M								1250	1950	305															2930

²⁾ All other dimensions according to execution KO (IM B3)
- Fixing dimensions obligatory, all other informal.

Dimensional sketches

HIGH VOLTAGE THREE PHASE
INDUCTION MOTORS WELDED
CONSTRUCTION

Rotor: slip ring

Execution: PZ

Arrangement: IM B3 (IM 1001)
Protect.: IP 54 (IP 55)
Cooling method: IC 611
Heat exchanger: air-air

46

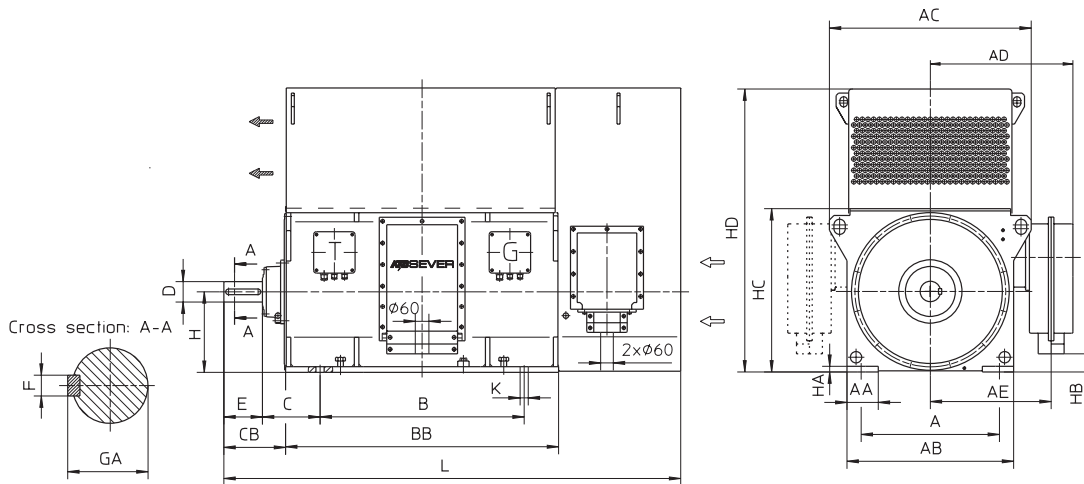

¹⁾ If request cable inlet can be delivered in range $\phi 60 - \phi 80$, or with two inlet holes $\phi 50 - \phi 70$.

Frame	2p	A	AA	AB	AC	AD	AE	B	BA	BB	BC	BD	BE	C	CB	D	E	F	GA	H	HA	HB	HC	HD	K	L	
355	S	4	610	131	735	890	630	535	800	350	1106	132	380	744	254	272	90	170	25	95	355	25	60	720	1253	36	1830
	M	4 - 6							900		1206	182		794													1930
400	S	4 - 10	686	151	835	990	680	585	900	380	1234	165	425	807	280	325	100	210	28	106	400	25	105	820	1353	36	2010
	M	4 - 10							1000		1334	215		857													2110
450	S	4 - 12	750	181	935	1090	730	635	1000	420	1396	206	520	888	315	325	110	210	28	116	450	25	155	920	1453	42	2175
	M	4 - 12							1120		1516	266		948													2295

²⁾ All other dimensions according to execution K0 (IM B3)
- Fixing dimensions obligatory, all other informal.

Note: All other motors frame sizes, executions and additional data are available on request; All quoted data are informal; Keeping back privilege for change in catalogue.

Dimensional sketches

HIGH VOLTAGE THREE PHASE
INDUCTION MOTORS WELDED
CONSTRUCTION

Rotor: slip ring

Execution: PZ

Arrangement: IM B3 (IM 1001)
Protect.: IP 54 (IP 55)
Cooling method: IC 611
Heat exchanger: air-air

47

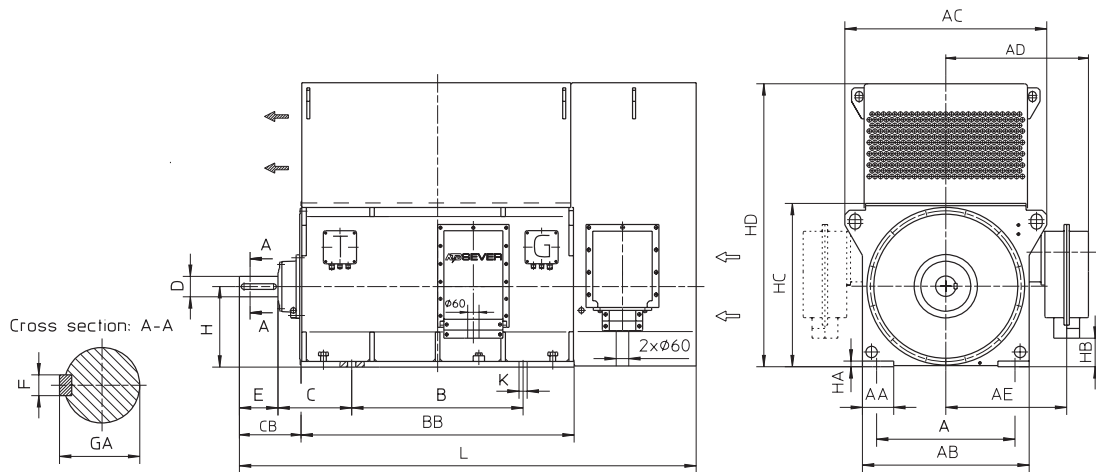

¹⁾ If request cable inlet can be delivered in range
 $\phi 60 - \phi 80$, or with two inlet holes $\phi 50 - \phi 70$.

Frame	2p	A	AA	AB	AC	AD	AE	B	BA	BB	BC	BD	BE	C	CB	D	E	F	GA	H	HA	HB	HC	HD	K	L
500	S	4 - 12	900	210	1050	1250	895	700	1000	1600	170	230	470	400	328	125	210	32	132	500	25	205	1010	1700	42	2580
	M								1120	1720	230															2700
560	S	4 - 12	950	300	1160	1360	910	755	1120	1820	230	230	470	500	388	140	250	36	148	560	25	265	1120	1850	42	2870
	M								1250	1950	305															3000

²⁾ All other dimensions according to execution KO (IM B3)
- Fixing dimensions obligatory, all other informal.

QUESTIONNAIRE FOR THE OFFER OF ASYNCHRONOUS ELECTRIC MOTORS

48



Enquiry Number: _____

Customer: _____ ITEM: _____
Qty: _____

A MOTOR DATA

1 Motor type: Three phase: _____ Single phase: _____

2 Rotor type: Squirrel cage: _____ Slip-ring: _____

3 Rated output: $P_N =$ _____ kW

4 Rated voltage: $U_N =$ _____ V Connect: Star _____ Delta _____

5 Rated frequency: $f_N =$ _____ Hz

6 Rated speed: $n_N =$ _____ rpm

7 Insulation class: F _____ B _____

8 Duty type: S1 S2 S3 S4 S5 S6 S7 S8 S9 S10
ED %
starts /h _____ min _____ J_{mot} _____ kgm^2

9 Standard: _____ IEC or _____

10 Cooling method: _____ IC _____

11 Mounting arrangement: IM _____

12 Protection degree: _____ Motor IP: _____ Terminal box IP: _____

13 *Sense of rotation: Left _____ Right _____ Both _____

14 Motor brake: yes _____ no _____
Braking moment: _____ Nm
Brake voltage: _____ V/Hz _____ V,DC _____

15 No-load regime? (single phase motor) yes _____ no _____

16 Rotor data: $U_{2c} =$ _____ V $I_{2n} =$ _____ A

B DATA ABOUT THE DRIVEN MACHINE

1 Type: _____

2 Required power: _____

3 Required speed: _____

4 Load torque characteristic:
Constant: _____ Squared _____ or _____
Speed %: 0 25 50 75 100
Torque Nm: _____

5 Moment of inertia: $J =$ _____ kgm^2

6 Running machine special data: _____

C AMBIENT CONDITIONS

1 Ambient temperature: _____ C

2 Relative humidity: _____ %

3 Altitude (above sea level): _____ m

4 Specific ambient conditions: _____

D POWER TRANSMISSION AND STARTING CONDITIONS

1 Coupling type: _____

2 Starting: _____

3 Number of consecutive startings:
Hot state: _____ Cold state: _____
_____ per hour _____ per hour
_____ per day _____ per day

E ADDITIONAL REQUESTS FOR MOTOR EXECUTION

1 Overloading from: _____ % P_N
Duration: _____ min

2 Temperature rise: F _____ B _____

3 Request for: vibration level _____ mm/s
noise level _____ db

4 *Terminal box position:
left _____ right _____ On top _____

5 Additional shaft loading sense
axial force _____ radial force _____

6 Converter feed operation: yes _____ no _____
Converter type: _____
Manufacturer: _____
Speed range: from _____ to _____ rpm

7 Sensor category (mark in lower field):
Tacho gen. _____ Encoder _____ Absolute _____ Resolver _____
Sensor Type: _____

8 Flange size: _____ mm

9 Second shaft end: yes _____ no _____
DA= _____ mm EA= _____ mm

10 Other requests and limits: _____

F ADDITIONAL EQUIPMENT, SPARE PARTS AND DOCUMENTATION

1 Thermal protection: yes _____ no _____
Type: _____

2 Bearings thermometers yes _____ no _____

3 Anti-condensation heaters yes _____ no _____

4 Spare parts yes _____ no _____

5 Guarantee sheet yes _____ no _____

6 Language of instruction list: _____

7 Other requests for packing: _____

H CUSTOMER

1 Company: _____

2 Address: _____

3 City: _____

4 Country: _____

5 Person: _____

6 Telefon / Telefax: _____

7 e-mail: _____

You are kindly requested to provide us with as much data as possible thus enabling us to offer satisfactorily

* OBSERVED FROM DRIVE END

Company locations

HEAD OFFICE AUSTRIA

ATB Austria Antriebstechnik AG

Renngasse 6-8
1010 Wien, Austria

T: +43 1 90 250 - 0
F: +43 1 90 250 110

info@atb-motors.com
www.atb-motors.com

AUSTRIA

ATB Motorenwerke GmbH

G.-Bauknecht-Str. 1
8724 Spielberg
T: +43 3577 757-323
F: +43 3577 757-182
info@atb-motors.com

ATB Technologies GmbH

Millenium Park 11
6890 Lustenau
T: +43 5577 9010-0
F: +43 5577 9010-110
info@atb-motors.com

ASIA

ATB Motorentechnik GmbH

141 Market Street,
07-01 International Factors
Building
Singapore 048944
T: +65 63721174
F: +65 62253524
dennis.tan@atbs.com.sg

BAHREIN

ATB Austria Antriebstechnik Aktiengesellschaft, Rep. Office Bahrain

Almoayyed Tower
21st Floor c/o Regus
Seef District, Manama
Kingdom of Bahrain
T: +973 175 68 160
F: +973 175 67 901

BENELUX

ATB BeNeLux B.V.

Tasveld 14
8271 RW IJsselmuiden
T: +31 38 443 2110
F: +31 38 443 2111
verkoop@nl.atb-motors.com

GERMANY

ATB Antriebstechnik GmbH

Silcherstraße 74
73642 Welzheim
T: +49 7182 14-535
F: +49 7182 14 590
info@de.atb-motors.com

ATB Motorentechnik GmbH

Helgoländer Damm 75
26954 Nordenham
T: +49 4731 365-0
F: +49 4731 365-159
info@de.atb-motors.com

Schorch Elektrische Maschinen und Antriebe GmbH

Breite Straße 131
41238 Mönchengladbach
T: +49 2166 925-0
T: +49 2166 925-100
mail@schorch.de

POLAND

Fabryka Silników Elektrycznych Tamel S.A.

ul. Elektryczna 6
33 100 Tarnow
T: +48 14 632 11 00
F: +48 14 632 11 02
officetamel@tamel.pl

RUSSIA

ATB Rus 000

Petrovka ul. 27
107031 Moscow
T: +7 495 95 66 326
vyacheslav.mikheyev@tecindustries.com

SERBIA

ATB SEVER D00 SUBOTICA

Magnetna polja 6
24000 Subotica
T: +381 24 665 100
F: +381 24 546 893
sever@rs.atb-motors.com

ATB FOD d.o.o.

Dorda Vajferta 16
19210 Bor
T: +381 30 423 147
fod@fod.co.rs

SWITZERLAND

ATB Schweiz AG

Industriestraße 28
5600 Lenzburg
T: +41 62 885 70-10
info@ch.atb-motors.com

UK & IRELAND

ATB Laurence Scott Ltd.

PO Box 25 Hardy Road, Norwich NR1 1JD
Norfolk
T: +44 1603 628 333
hvm.sales@laurence-scott.com

ATB Morley Limited

Bradford Road
Leeds LS28 6QA
West Yorkshire
T: +44 113 257 1734
sales@uk.atb-motors.com

Brook Crompton UK

St. Thomas Road, Huddersfield HD1 3LJ
West Yorkshire
T: +44 1484557200
F: +44 1484557201
csc@brookcrompton.com

CANADA

Brook Crompton

North America
264 Attwell Drive
M9W 5B2 Toronto, Ontario
T: +1 416 675-3844
ramzi.mallouk@brookcromptonna.com

ATB SEVER DOO SUBOTICA

Magnetna polja 6

24 000 Subotica

Serbia

Tel. +381 24 665-124

Fax +381 24 665-125

www.atb-motors.com

sever@rs.atb-motors.com