

We produce fluid power solutions



Fluid Management

- Off-line Filters
- Off-line Filter Units
- Oil Service Units
- Dewatering Systems
- Filter Elements



Products with these icons are specially made for:
Industrial Applications



Mobile Applications

Content

Content	5
Product range	7
Off-line Filters	
FN1 040.....	13
FN 060 · FN 300.....	19
FNS 040.....	25
FNS 060.....	29
Off-line Filter Units	
FNA 014.....	35
FNA1 008 / 016.....	37
FNA1HV 008 / 016.....	43
FNA 040-553.....	47
FNA 045.....	51
FNAPC1 045.....	57
FNU 008.....	63
Oil Service Units	
CFP 03.....	67
FA1 / FA1HV 008.....	71
FA 016 · FAPC 016.....	75
UM 045 · UMPC 045.....	81
UMPCL 045 Lightline.....	87
FA 003-2341.....	91
FA 016-1160.....	95
Suction Strainer Set FA 016.1775.....	99
Mounting Set FNA 008.1700.....	101
OPS 010 · OPS 550.....	103
Filter Elements	
EXAPOR®AQUA.....	107

Filtration

Suction filters



Return-suction filters



Return filters



Pressure filters



High pressure filters

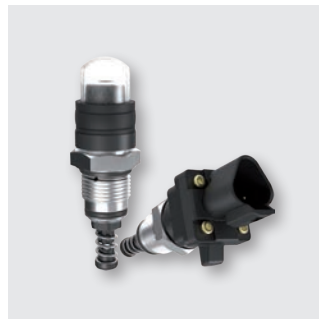

Clogging Indicators



Tank solutions



Filling and ventilating filters

Description

ARGO-HYTOS produces sophisticated filter solutions together with hydraulic and lubrication systems. The range of solutions we have implemented extends from fixed-position industrial plants to mobile applications.

As well as customized developments, exactly adjusted to the individual requirements of the customer, ARGO-HYTOS offers a comprehensive range of innovative standard solutions for a wide variety of applications:

- › Suction filters
- › Return-suction filters and return filters
- › Pressure and high pressure filters
- › Filling and ventilating filters
- › Tank solutions
- › Filter and tank accessories

Fluid and Motion Control



Customized solutions



Control solutions



Gear pumps

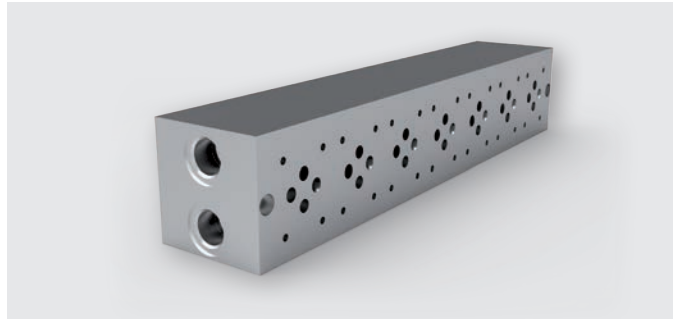

Plates

Fluid and Motion Control



Directional and proportional valves



Modular valves

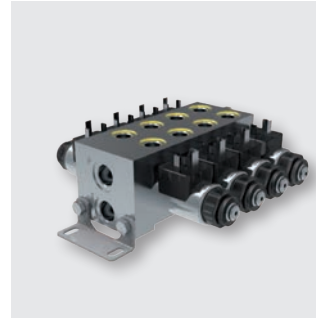

Bankable modular valve assembly



Screw-in cartridge valves



Slip-in cartridge valves



Load motion cartridges



Explosion proof valves

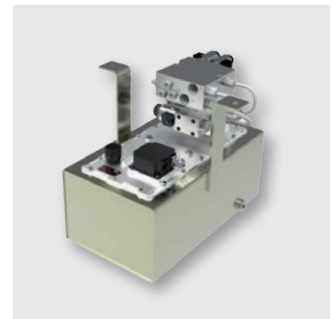

Hydraulic power packs

Description

ARGO-HYTOS' expertise in control technology is the fruit of more than 70 years' experience. We focus here on a wide range of valves, power units and integrated manifolds featuring all commonly used design features and functions, together with proportional valves and the associated control electronics:

- › Directly operated directional valves in CETOP 02 to CETOP 05 and pilot operated directional valves in CETOP 07 and CETOP 08
- › Valves sub-plate and sandwich type – flow control, pressure and check valves in CETOP 02 to CETOP 05
- › Cartridge valves
- › Directly activated proportional valves with compensator sandwich valve, in CETOP 02 to CETOP 05
- › Analog and digital control electronics – on-board, or for installation in control cabinets
- › Power pack assembly kits
- › Customized control blocks

Fluid Management



Off-line filter



Off-line filter



Off-line filter unit



Off-line filter unit



Oil service unit



Oil service unit



Compact filter pack



Dewatering system

Description

As well as reducing maintenance and servicing costs, effective fluid management is also a key factor in boosting the reliability, productivity and cost-effectiveness of the operation. ARGO-HYTOS supplies application-oriented products for manual and automatic cleaning of hydraulic fluids:

- › Off-line filters
- › Off-line filter units
- › Oil service units
- › Dewatering systems
- › Compact filter pack

Sensors and Measurement



Portable particle counter



Portable particle monitor



Particle monitor



Wear sensor



Humidity sensor



Condition sensors



Remote interfaces / display units

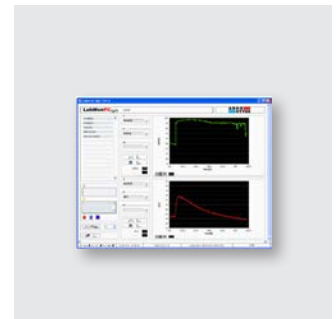

Software

Description

Systems that provide reliable assessment of the condition of hydraulic fluids are the key feature of continuous fluid monitoring.

The sensors and measurement technology from ARGO-HYTOS precisely targets this range of tasks. Our fluid monitoring products comprise equipment and system solutions to enable online monitoring during continuous operation as well as analysis of bottled samples under laboratory conditions.

- › Portable oil diagnosis equipment
- › Stationary and portable particle monitor
- › Oil condition sensors
- › Software to evaluate data and analyze trends

Off-line Filters**FN1 040**

In-line mounting · Operating pressure up to 12 bar / 174 psi · Nominal flow rate 40 l/min / 10.6 gpm



Off-line Filter FN1 040

Description**Application**

Return-flow filter or off-line filter in hydraulic and lubrication systems.

Performance features

The EXAPOR®MAX 2 and EXAPOR®AQUA ultra-fine elements are the heart of the ARGO-HYTOS off-line filters. High separation efficiencies guarantee excellent cleanliness levels and thereby highest protection of components. The high dirt and water capacity of the EXAPOR®MAX 2 and EXAPOR®AQUA elements allows economical operation of the machine.

Special design features*User-friendly filter element change:*

The cover of the FN 040 can be opened without special auxiliary tools. The filter element can be removed from the housing together with the cover.

Dirt retention valve:

The element is flown through from the inside to the outside. The built-in dirt retention valve closes automatically when the element is removed, ensuring that all dirt is removed from the housing together with the element. Because of the cover design, the filter element change can be carried out almost without losing any oil.

Filter elements

Flow direction from the inside to the outside. The star-shaped pleating of the filter material results in:

- › large filter surfaces
- › low pressure drop
- › high dirt-holding capacities
- › particularly long maintenance intervals

Operating pressure

Max. 12 bar / 174 psi

Cracking pressure of by-pass

3.5 bar / 51 psi

Nominal flow rate

40 l/min / 10 gpm up to 60 l/min / 15 gpm

The nominal flow rates indicated by ARGO-HYTOS are based on the following features:

- › closed by-pass valve at $v \leq 200 \text{ mm}^2/\text{s}$ / 930 SUS
- › element service life > 1000 operating hours at an average fluid contamination of 0.07 g per l/min / 0.27 g per gpm flow volume
- › flow velocity in the connection lines:
up to 10 bar $\leq 4.5 \text{ m/s}$ / 145 psi $\leq 14.8 \text{ ft/s}$

Filter fineness

- › 3 $\mu\text{m(c)}$... 10 $\mu\text{m(c)}$ for EXAPOR®MAX 2 separating solid particles
- › 3 $\mu\text{m(c)}$... 7 $\mu\text{m(c)}$ for EXAPOR®AQUA separating water and solid particles

β -values according to ISO 16889

(see Ordering Code, table filter element)

Dirt-holding capacity

The dirt-holding capacity values in grams from the ISO MTD test dust are in accordance with the ISO 16889 requirements (see Ordering Code, table Filter Element).

Materials

Filter housing: Aluminum alloy powder painted RAL 5015

Filter end plate: Aluminum alloy

Cover: Aluminum alloy

Seals: NBR (FPM on request)

Filter media: EXAPOR®MAX 2 - inorganic, multi-layer microfiber web
EXAPOR®AQUA - combination of water absorbing filter layers and inorganic, multi-layer microfiber web

Remarks

Other colors of the filter housing are available on request. Special versions, not shown in this catalog, are also available on request.

Hydraulic fluids

Mineral oil and biodegradable fluids
(HEES and HETG, see info-sheet 00.20)

Temperature range

-30 °C ... +100 °C (temporary -40 °C ... +120 °C)

-22 °F ... +212 °F (temporary -40 °F ... +248 °F)

Viscosity at nominal flow rate

- › at operating temperature: $v < 35 \text{ mm}^2/\text{s}$ / 162 SUS
- › as starting viscosity: $v_{\text{max}} = 1200 \text{ mm}^2/\text{s}$ / 5560 SUS
- › at initial operation:
The recommended starting viscosity can be read from the diagram D (pressure drop as a function of the kinematic viscosity) as follows: Find the 70% Δp of the cracking pressure of the by-pass valve on the vertical axis. Draw a horizontal line so that it intersects the Δp curve at a point. Read this point on the horizontal axis for the viscosity.

Mounting position

Vertical, connection port at the bottom

Weight

Without mounting clamps: 6.7 kg / 14.77 lbs

With mounting clamps: 8.3 kg / 18.3 lbs

Connection

Threaded ISO 228 or UNF ports
(see Dimensions Drawing)

Accessories

A mounting kit (2 pcs of mounting clamps) may be ordered together with the off-line filter (M in the order code) or separately (order code FNS 060.1730).

Electrical and / or optical clogging indicators may be ordered together with the off-line filter. For choosing the proper clogging indicator, see table Clogging Indicator in the Ordering Code. The clogging indicator can be ordered separately. For dimensions and technical data of the clogging indicators, see catalog sheets 60.20 and 60.30.

Ordering Code

FN1 040 - - - -

Type of filter	Code
Off-line filter	FN1

Nominal flow rate	Code
40 l/min / 10 gpm	040

Connection port	Code
In: G1 Out: G ³ / ₄	G
In: 1 ⁵ / ₁₆ -12 UN-2B Out: 1 ¹ / ₁₆ -12 UN-2B	U

Filter element						Code
	Fineness (β=200) Dirt-holding capacity at nominal flow 40 l/min / 10 gpm	Water capacity	Cracking pressure of by-pass	Spare filter element code		
EXAPOR®MAX 2	3 μm	190 g	-	3.5 bar / 51 psi	V7.1220-113	V003
EXAPOR®MAX 2	5 μm	190 g	-	3.5 bar / 51 psi	V7.1220-13	V005
EXAPOR®MAX 2	10 μm	148 g	-	3.5 bar / 51 psi	V7.1220-06	V010
EXAPOR®AQUA	3 μm	80.5 g	300 ml	3.5 bar / 51 psi	Y7.1220-113	Y003
EXAPOR®AQUA	7 μm	60.5 g	330 ml	3.5 bar / 51 psi	Y7.1220-05	Y007

Clogging indicator					Code
Type		Code of indicator	Connection	Hydraulic symbol	
Manometer	optical	DG 200-16	M12 x 1.5	1	O
Pressure switch	electrical	DG 813-21	M12 x 1.5	2	E
Pressure switch	optical / electrical	DG 815-12	M12 x 1.5	3	EO
	without indicator		M12 x 1.5	4	X
Differential pressure clogging indicator	optical	DG 042-01	Flange	5	OD
	electrical	DG 041-32	Flange	6	ED
	optical / electrical	DG 041-44	Flange	7	EOD
	without indicator		Flange	8	XD

Mounting clamps	Code
No	
Yes	M

Order example:

FN1 040G-Y003-ED off-line filter with inlet port G1, outlet port G³/₄, water absorbing filter element 3μm, electrical differential pressure clogging indicator, without mounting clamps.

Remarks:

Combinations listed in this order code are standard units. If modifications are required, we kindly ask for your request. For preferred types (available in short time) see table at the last page of this data sheet.

D1 FN1 040 with **EXAPOR®MAX 2** filter element
Pressure drop as a function of the **flow volume**
at $v = 35 \text{ mm}^2/\text{s} / 162 \text{ SUS}$

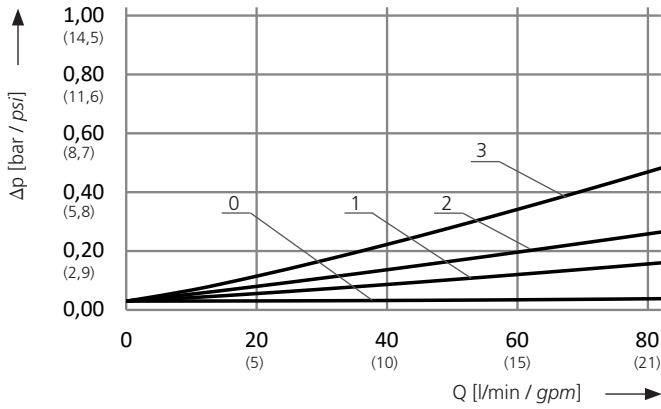

- 0 = housing empty
- 1 = with EXAPOR®MAX 2 filter element 10 μm
- 2 = with EXAPOR®MAX 2 filter element 5 μm
- 3 = with EXAPOR®MAX 2 filter element 3 μm

FN1 040 with **EXAPOR®MAX 2** filter element
Pressure drop as a function of the **kinematic viscosity**
at nominal flow

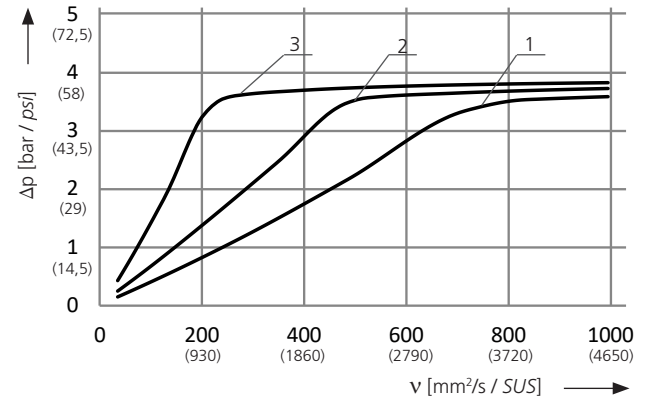

D2 FN1 040 with **EXAPOR®AQUA** filter element
Pressure drop as a function of the **flow volume**
at $v = 35 \text{ mm}^2/\text{s} / 162 \text{ SUS}$

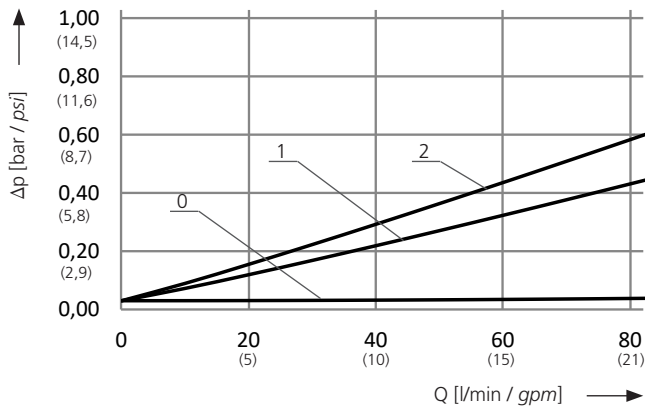

- 0 = housing empty
- 1 = with EXAPOR®AQUA filter element 7 μm
- 2 = with EXAPOR®AQUA filter element 3 μm

FN1 040 with **EXAPOR®AQUA** filter element
Pressure drop as a function of the **kinematic viscosity**
at nominal flow

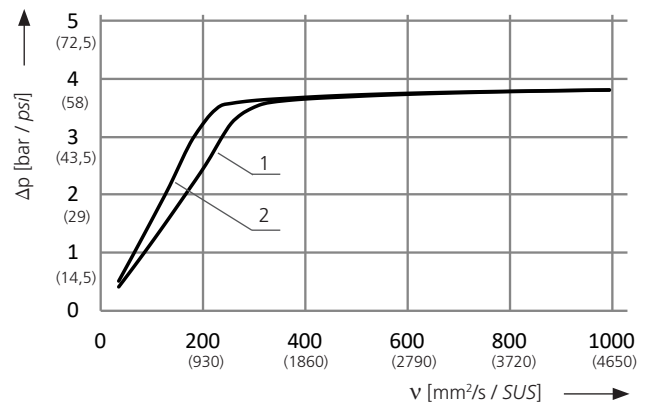

Dimensions

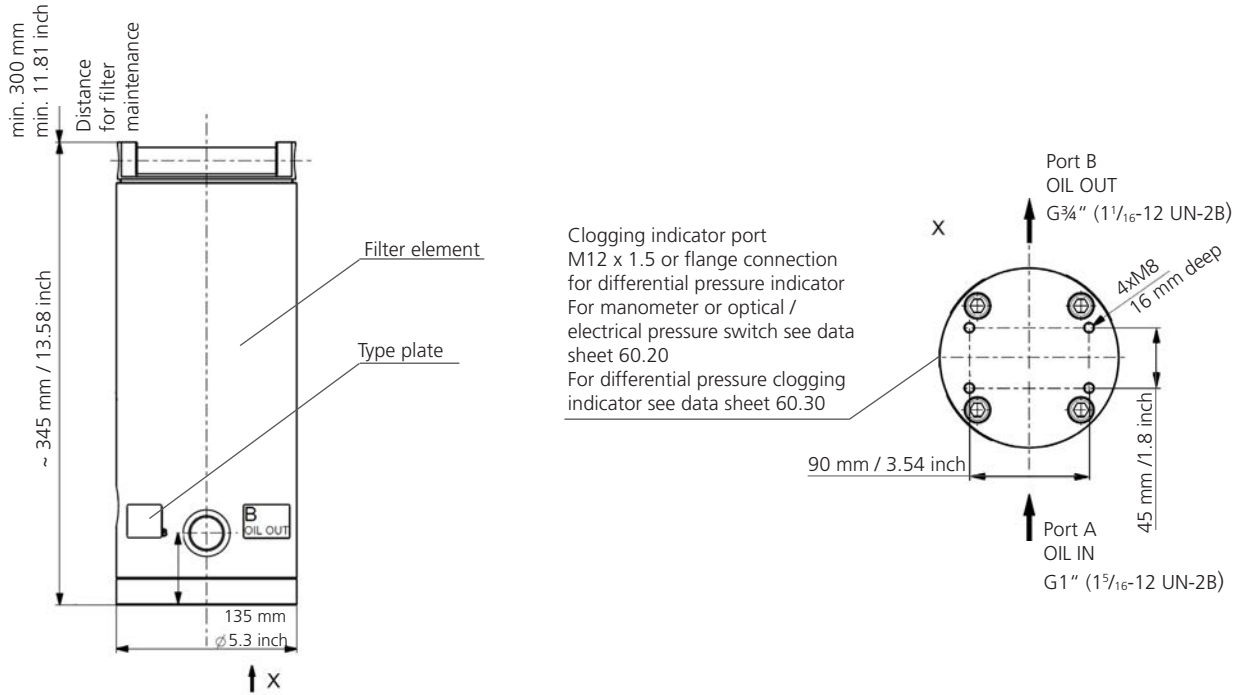

Version with mounting clamps (order code M)

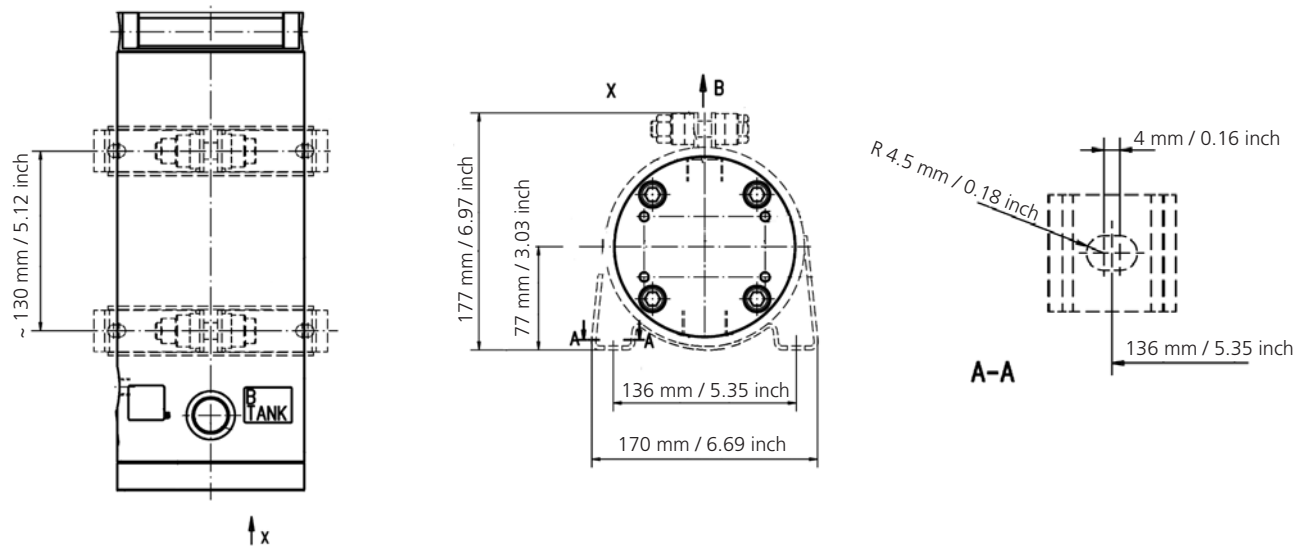

Preferred types

Order code	Port A	Port B	Filter fineness ($\beta=200$)	Dirt-holding capacity	Water capacity	Replacement filter element	Hydraulic symbol	SAP number
FN1 040G-V003-X	G1	G $\frac{3}{4}$	3 μ m	190 g	-	V7.1220-113	4	42496500
FN1 040G-V003-XD	G1	G $\frac{3}{4}$	3 μ m	190 g	-	V7.1220-113	8	42496700
FN1 040G-Y003-X	G1	G $\frac{3}{4}$	3 μ m	80.5 g	300 ml	Y7.1220-113	4	42496200
FN1 040G-Y003-XD	G1	G $\frac{3}{4}$	3 μ m	80.5 g	300 ml	Y7.1220-113	8	42496300
FN1 040U-V003-X	1 $\frac{5}{16}$ -12 UN-2B	1 $\frac{1}{16}$ -12 UN-2B	3 μ m	190 g	-	V7.1220-113	4	42496400
FN1 040U-V003-XD	1 $\frac{5}{16}$ -12 UN-2B	1 $\frac{1}{16}$ -12 UN-2B	3 μ m	190 g	-	V7.1220-113	8	42496600

Hydraulic symbols

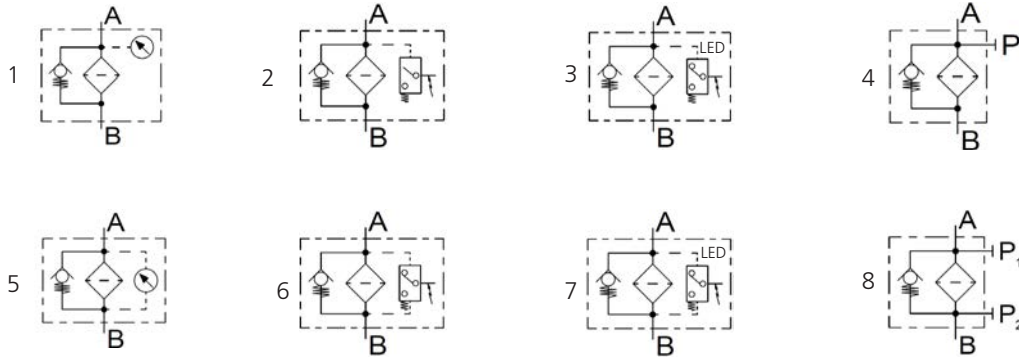

Quality Assurance

Quality management according to DIN EN ISO 9001

To ensure constant quality in production and operation, ARGO-HYTOS filter elements undergo strict controls and tests according to the following ISO standards:

ISO 2941	Verification of collapse / burst pressure rating
ISO 2942	Verification of fabrication integrity (Bubble Point Test)
ISO 2943	Verification of material compatibility with fluids
ISO 3968	Evaluation of pressure drop versus flow characteristics
ISO 16889	Multi-Pass-Test (evaluation of filter fineness and dirt-holding capacity)
ISO 23181	Determination of resistance to flow fatigue using high viscosity fluid

Various quality controls during the production process guarantee the leak-free function and solidity of our filters.

Illustrations may sometimes differ from the original. ARGO-HYTOS is not responsible for any unintentional mistake in this specification sheet.

Off-line Filters
FN 060 · FN 300

In-line mounting · Operating pressure up to 12 bar / 174 psi · Nominal flow rate up to 650 l/min / 172 gpm



Off-line Filter FN 060



Off-line Filter FN 300

Description
Application

Return-flow filter or off-line filter in hydraulic and lubrication systems.

Performance features
Protection against wear:

The EXAPOR®MAX 2 ultra-fine element meets the highest cleanliness standards, even at full flow.

Protection against failure:

The off-line filter includes a feature that guarantees a closed by-pass valve even at $v \leq 200 \text{ mm}^2/\text{s}$ / 930 SUS (cold start condition) within specified operating parameters.

Special design features
Housing cover:

The cover of the FN 060 can be opened without special auxiliary tools. Fold-out handle parts at the cover of the FN 300 facilitate the opening.

Automatic ventilation valve (only FN 300):

The quick automatic de-aeration after commissioning not only prevents components from consequential damage due to an excessive air content, but also avoids errors in the monitoring with optical particle counters.

Dirt retention valve:

At the bottom of the filter element, flow through from the inside to the outside, there is a dirt retention valve. This closes while pulling the filter element, which is hung up at the cover, out of the housing. Sedimented dirt is removed together with the filter element. Because of the cover design, the filter element change can be carried out almost without losing any oil.

Filter elements

Flow direction from the inside to the outside. The star-shaped pleating of the filter material results in:

- › large filter surfaces
- › low pressure drop
- › high dirt-holding capacities
- › particularly long maintenance intervals

Filter maintenance

By using a clogging indicator, the correct moment for maintenance is stated, what guarantees optimum utilization of the filter life.

Materials:

Filter head:	Aluminum alloy
Filter housing:	Steel (FN 060) Aluminum alloy (FN 300)
Cover:	Aluminum alloy
Seals:	NBR (FPM on request)
Filter media:	EXAPOR®MAX 2 - inorganic, multi-layer microfiber web

Accessories

Water-absorbing filter elements EXAPOR®AQUA are available on request.
For FN 060 there is a bleeder screw, and with Part No. FNS 060.1720 a fastening kit available on request.
Electrical and / or optical clogging indicators are available on request – with either one or two switching points resp. temperature suppression.
For dimensions and technical data of the clogging indicators see catalog sheet 60.30.

Characteristics

Operating pressure

Max. 12 bar / 174 psi (FN 060)
Max. 10 bar / 145 psi (FN 300)

Nominal flow rate

Up to 650 l/min / 172 gpm (see Selection Chart, column 2)
The nominal flow rates indicated by ARGO-HYTOS are based on the following features:

- › closed by-pass valve at $v \leq 200 \text{ mm}^2/\text{s}$ / 930 SUS
- › element service life > 1000 operating hours at an average fluid contamination of 0.07 g per l/min / 0.27 g per gpm flow volume
- › flow velocity in the connection lines:
up to 10 bar $\leq 4.5 \text{ m/s}$ / 145 psi $\leq 14.8 \text{ ft/s}$

Filter fineness

3 $\mu\text{m(c)}$... 10 $\mu\text{m(c)}$
 β -values according to ISO 16889
(see Selection Chart, column 4 and Diagram Dx)

Dirt-holding capacity

The dirt-holding capacity values in grams from the ISO MTD test dust are in accordance with the ISO 16889 requirements (see Selection Chart, column 5).

Hydraulic fluids

Mineral oil and biodegradable fluids
(HEES and HETG, see info-sheet 00.20)

Temperature range

-30 °C ... +100 °C (temporary -40 °C ... +120 °C)
-22 °F ... +212 °F (temporary -40 °F ... +248 °F)

Viscosity at nominal flow rate

- › at operating temperature: $v < 35 \text{ mm}^2/\text{s}$ / 162 SUS
- › as starting viscosity: $v_{\text{max}} = 1200 \text{ mm}^2/\text{s}$ / 5560 SUS
- › at initial operation:
The recommended starting viscosity can be read from the diagram D (pressure drop as a function of the kinematic viscosity) as follows: Find the 70% Δp of the cracking pressure of the by-pass valve on the vertical axis. Draw a horizontal line so that it intersects the Δp curve at a point. Read this point on the horizontal axis for the viscosity.

Mounting position

Vertical, connection port at the bottom

Connection

Threaded ports according to ISO 228 or DIN 13 (FN 060) or flange mounting according to SAE-J518 (FN 300).
For sizes see Selection Chart, column 6 (other port threads on request).

Δp-curves for complete filters in Selection Chart, column 3

D1 Pressure drop as a function of the **flow volume** at $v = 35 \text{ mm}^2/\text{s} / 162 \text{ SUS}$ (0 = casing empty)

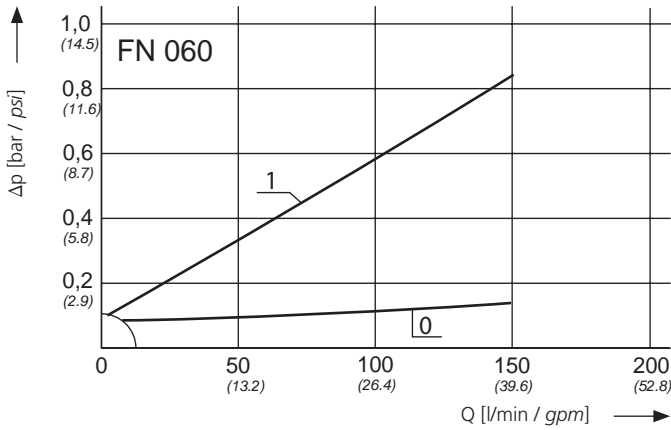

Pressure drop as a function of the **kinematic viscosity** at nominal flow

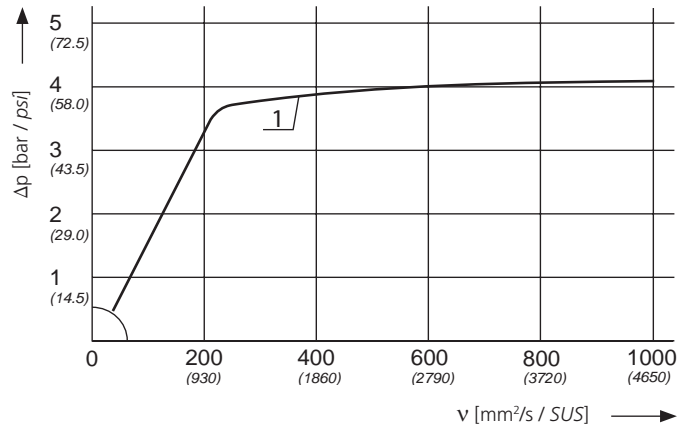

D2 Pressure drop as a function of the **flow volume** at $v = 35 \text{ mm}^2/\text{s} / 162 \text{ SUS}$ (0 = casing empty)

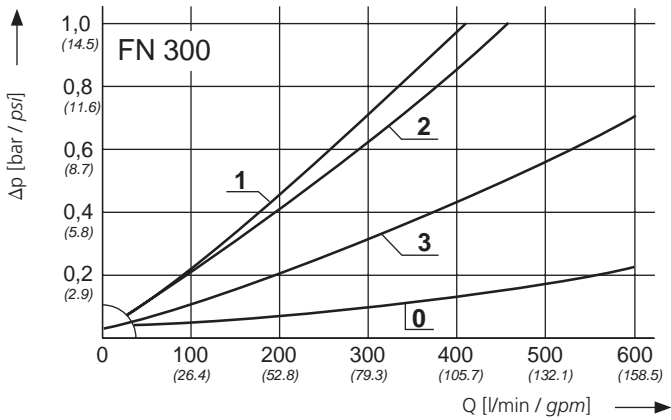

Pressure drop as a function of the **kinematic viscosity** at nominal flow

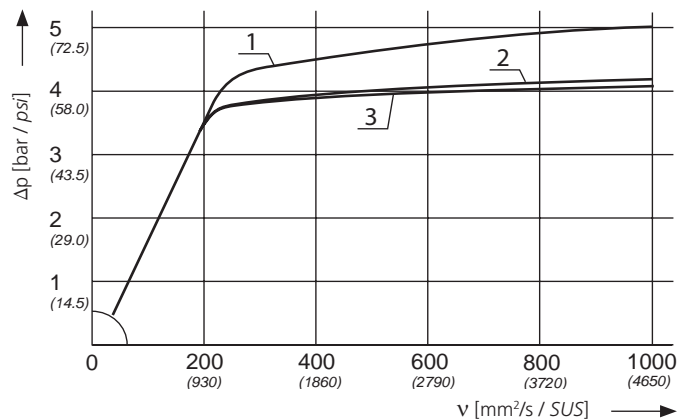

Filter fineness curves in Selection Chart, column 4

Dx Filtration ratio β as a function of particle size x obtained by the Multi-Pass Test according to ISO 16889

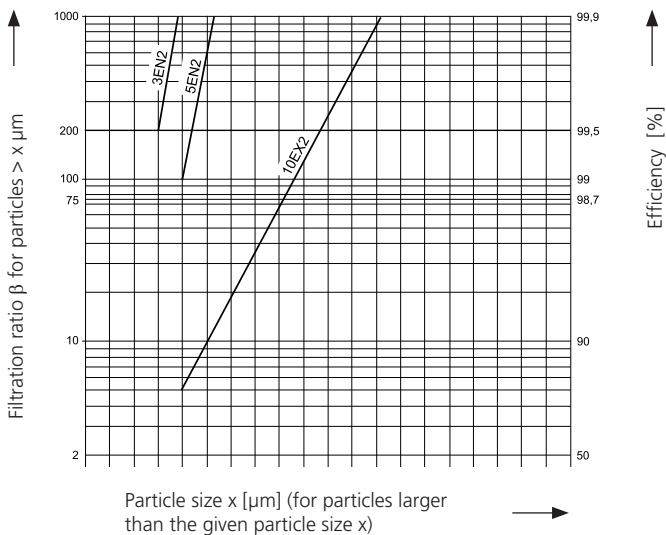

The abbreviations represent the following β -values resp. finenesses:

With EXAPOR[®]MAX2 and paper elements:

3EN2	=	$\bar{\beta}_3(c) = 200$	EXAPOR [®] MAX 2
5EN2	=	$\bar{\beta}_5(c) = 200$	EXAPOR [®] MAX 2
10EX2	=	$\bar{\beta}_{10}(c) = 200$	EXAPOR [®] MAX 2

For special applications, finenesses differing from these curves are also available by using special composed filter media.

Selection Chart

Part No.	Nominal flow rate		Pressure drop see diagram D /curve no.	Filter fineness s. diagram Dx	Dirt-holding capacity	Connection A/B		Cracking pressure of by-pass	Symbol	Replacement filter element Part No.	Weight		Clogging indicator	Remarks
	l/min	gpm				g	bar				psi	kg		
1	2	3	4	5	6	7		8	9	10		11	12	
FN 060-193	60	15.9	D1 /1	3EN2	290	G1	3.5	51	1	V7.1230-153	5	11.0	DG 041-32	–
FN 060-273	115	30.4	D1 /1	5EN2	220	G1	3.5	51	2	V7.1230-53	5	11.0	optional	–
FN 300-163	250	66.0	D2 /1	3EN2	740	SAE2½	3.5	51	2	V7.1560-103	20	44.1	optional	*
FN 300-153	300	79.3	D2 /2	5EN2	600	SAE2½	3.5	51	2	V7.1560-03	20	44.1	optional	*
FN 300-156	650	171.7	D2 /3	10EX2	400	SAE2½	3.5	51	2	V7.1560-06	20	44.1	optional	*

* with automatic ventilation valve

Optical or electrical indicators are available to monitor the clogging condition of the element.

For appropriate clogging indicators, please refer to catalog sheet 60.30.

Remarks:

- › The response / switching pressure of the clogging indicator must be lower than the cracking pressure of the by-pass valve (see Selection Chart, column 7).
- › Clogging indicators are optionally available and will be supplied separately if ordered.
- › The filter units listed in this chart are standard units. If modifications are required, e.g. with water-absorbing filter elements or with mounting set, we kindly ask for your request.

Dimensions

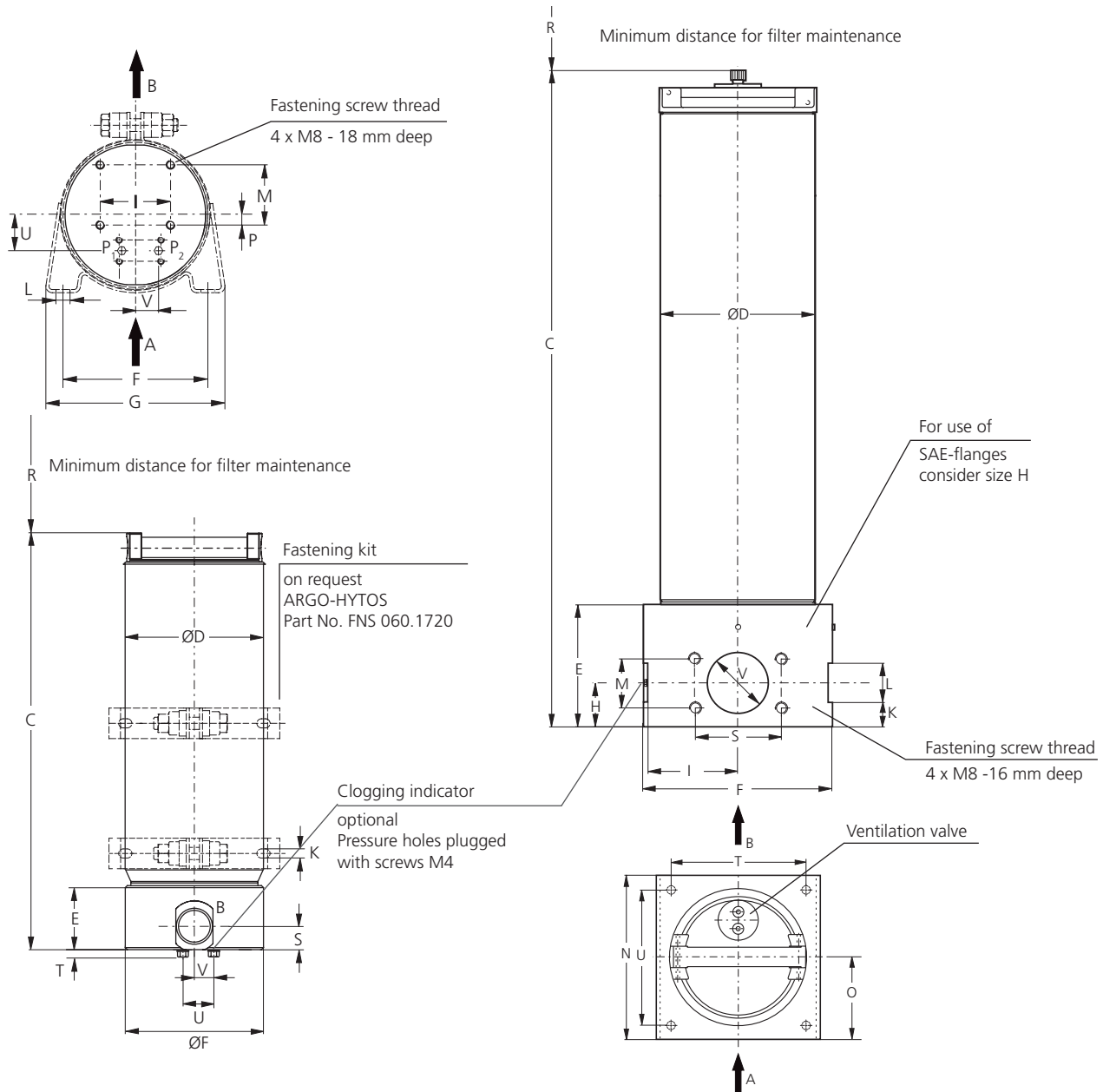

Measurements in mm

Type	A / B	C	D	E	F	G	H	I	K	L	M	N	O	P	R	S	T	U	V
FN 060	G1	410	140	63	136	170	-	66	9	12	56.5	-	-	9.5	300	23	4	34	21
FN 300	SAE 2½	775	160	126	200	-	45	96	25	40	50.8	195	97.5	-	700	88.9	170	165	63

Measurements in inch

Type	A / B	C	D	E	F	G	H	I	K	L	M	N	O	P	R	S	T	U	V
FN 060	G1	16.14	5.51	2.48	5.35	6.69	-	2.60	0.35	0.47	2.22	-	-	0.37	11.81	0.91	0.16	1.34	0.83
FN 300	SAE 2½	30.51	6.30	4.96	7.87	-	1.77	3.78	0.98	1.57	2.00	7.68	3.84	-	27.56	3.50	6.69	6.50	2.48

Symbol

1

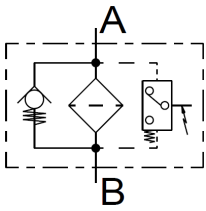

2

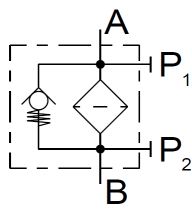

Quality Assurance

Quality management according to DIN EN ISO 9001

To ensure constant quality in production and operation, ARGO-HYTOS filter elements undergo strict controls and tests according to the following ISO standards:

- ISO 2941 Verification of collapse / burst pressure rating
- ISO 2942 Verification of fabrication integrity (Bubble Point Test)
- ISO 2943 Verification of material compatibility with fluids
- ISO 3968 Evaluation of pressure drop versus flow characteristics
- ISO 16889 Multi-Pass-Test (evaluation of filter fineness and dirt-holding capacity)
- ISO 23181 Determination of resistance to flow fatigue using high viscosity fluid

Various quality controls during the production process guarantee the leak-free function and solidity of our filters.

Illustrations may sometimes differ from the original. ARGO-HYTOS is not responsible for any unintentional mistake in this specification sheet.

Off-line Filter
FNS 040

Operating pressure up to 320 bar / 4640 psi · Nominal flow rate up to 6 l/min / 1.6 gpm · Water capacity approx. 350 ml / 0.09 gal



Off-line Filter FNS 040

Description
Application

Suitable for high-pressure circuits in hydraulic and lubrication systems.

Performance features
Protection against wear:

The EXAPOR[®]MAX 2 ultra-fine element meets the highest cleanliness standards, even at full flow.

Protection against failure:

The off-line filter includes a feature that guarantees a closed by-pass valve even at $v \leq 200 \text{ mm}^2/\text{s}$ / 930 SUS (cold start condition) within specified operating parameters.

Special design features
Housing cover:

The cover can be opened without special auxiliary tools.

Flow control valve:

Through a pressure compensated flow control valve, the FNS off-line filters are directly connected to the high pressure pipe. The surplus volume (e.g. in circuits with fixed displacement pumps) from the high-pressure circuit is cleaned by the ultra-fine filter element.

Dirt retention valve:

At the bottom of the filter element, flow through from the inside to the outside, there is a dirt retention valve. This closes while pulling the filter element, which is hung up at the cover, out of the housing. Sedimented dirt is removed together with the filter element. Because of the cover design, the filter element change can be carried out almost without losing any oil.

Filter elements

Flow direction from the inside to the outside. The star-shaped pleating of the filter material results in:

- › large filter surfaces
- › low pressure drop
- › high dirt-holding capacities
- › particularly long maintenance intervals

Filter maintenance

By using a clogging indicator, the correct moment for maintenance is stated, what guarantees optimum utilization of the filter life.

Materials

Filter housing: Aluminum alloy
Cover: Aluminum alloy
Seals: NBR (FPM on request)
Filter media: EXAPOR®AQUA

Accessories

EXAPOR®MAX 2 filter elements are available on request.

Characteristics

Nominal flow rate

Up to 6 l/min / 1.6 gpm (see Selection Chart, column 2)
Refers to the medium flow rate of the flow control valve. With selection of the flow control valve, a sufficient surplus volume from the high-pressure circuit has to be guaranteed. If necessary, the machine manufacturer should be consulted.

Connection

Threaded port according to ISO 228 or DIN 13.
Sizes see Selection Chart, column 6
(other port threads on request)

Hydraulic fluids

Mineral oil and biodegradable fluids
(HEES and HETG, see info-sheet 00.20)

Temperature range

-30 °C ... +100 °C (temporary -40 °C ... +120 °C)
-22 °F ... +212 °F (temporary -40 °F ... +248 °F)

Viscosity at nominal flow rate

- › at operating temperature: $v < 35 \text{ mm}^2/\text{s} / 162 \text{ SUS}$
- › as starting viscosity: $v_{\text{max}} = 400 \text{ mm}^2/\text{s} / 5560 \text{ SUS}$

Operating pressure

Max. 320 bar / 4640 psi
(max. 12 bar / 174 psi without pressure compensated flow control valve)
Minimum inlet pressure at the pressure compensated flow control valve: 10 bar / 145 psi

Mounting position

Vertical, connection port at the bottom

Diagrams

Δp -curves for complete filters in Selection Chart, column 3

D1 Flow volume as a function of the differential pressure at the flow control valve at $v = 35 \text{ mm}^2/\text{s} / 162 \text{ SUS}$

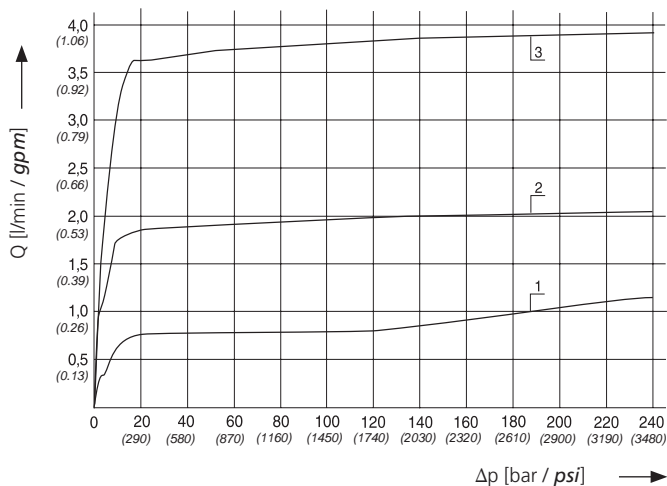

Selection Chart

Part No.	Nominal flow rate		Filter fineness			Dirt-holding capacity		Water capacity	Connection A/B	Replacement filter element		Clogging indicator	Flow control valve	Remarks
	l/min	gpm	µm	g	ml	gal	Part No.			kg	lbs			
1	2		3	4	5		6	7	8		9	10	11	
FNS 040-1105	6	1.6	7µm	65	350	0.09	G1/G¾	Y7.1220-05	8.8	19.4	optical	FNS 060.1550	–	
FNS 040-1115	4	1.06	7µm	65	350	0.09	G1/G¾	Y7.1220-05	7.2	15.9	optical	FNS 060.1540	–	
Pressure compensated flow control valve - inlet pressure min. 10 bar / 145 psi, max. 320 bar / 4640 psi:														
FNS 060.1520	1	0.26					G1/G¾						–	
FNS 060.1530	2	0.53					G1/G¾						–	
FNS 060.1540	4	1.06					G1/G¾						–	

Combinations with other filter elements are available on request.

Possible elements to choose:

V7.1220-113	3 µm
V7.1220-13	5 µm
V7.1220-06	10 µm
Y7.1220-05	7 µm, water absorbing
Y7.1220-113	3 µm, water absorbing

The housing of the off-line filter is designed for a max. operating pressure of 12 bar / 174 psi. To avoid back pressures, no components such as ball valves must be inserted at the housing outlet and in the continuative circuit.

For contamination monitoring, manometers or electrical pressure switches can be used.

For appropriate clogging indicators, please refer to catalog sheet 60.20.

Remarks:

- › The cut-in pressure of the pressure switch must be lower than the cracking pressure of the by-pass valve (see Selection Chart, column 7).
- › Clogging indicators and flow control valves are optionally available and will be supplied separately if ordered.
- › The off-line filters listed in this chart are standard units. If modifications are required, e.g. with water-absorbing filter elements, we kindly ask for your request.

Dimensions

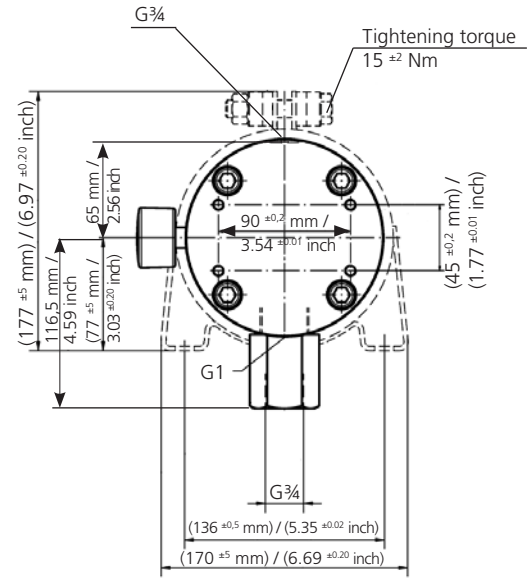
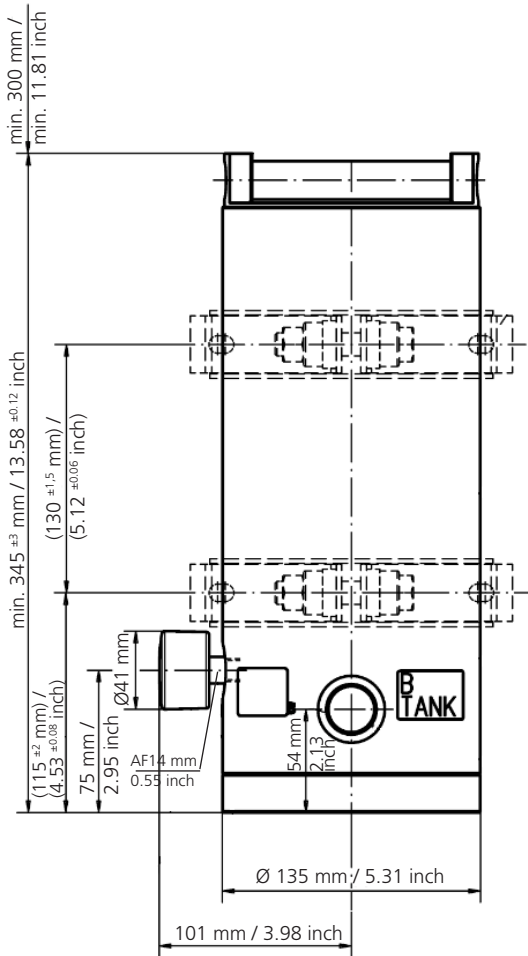

Version FNS 040-1115 without clamps.
Clamps may be ordered separately.
Order Code FNS 060.1730 (2 clamps).

Symbol

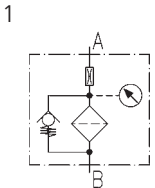

Quality Assurance

Quality management according to DIN EN ISO 9001

To ensure constant quality in production and operation, ARGO-HYTOS filter elements undergo strict controls and tests according to the following ISO standards:

- ISO 2941 Verification of collapse / burst pressure rating
- ISO 2942 Verification of fabrication integrity (Bubble Point Test)
- ISO 2943 Verification of material compatibility with fluids
- ISO 3968 Evaluation of pressure drop versus flow characteristics
- ISO 16889 Multi-Pass-Test (evaluation of filter fineness and dirt-holding capacity)
- ISO 23181 Determination of resistance to flow fatigue using high viscosity fluid

Various quality controls during the production process guarantee the leak-free function and solidity of our filters.

Illustrations may sometimes differ from the original. ARGO-HYTOS is not responsible for any unintentional mistake in this specification sheet.

Off-line Filter**FNS 060**

With flow control valve · Operating pressure up to 320 bar / 4640 psi · Nominal flow rate up to 4 l/min / 1.1 gpm



Off-line Filter FNS 060

Description**Application**

Suitable for high-pressure circuits in hydraulic and lubrication systems.

Performance features*Protection against wear:*

The EXAPOR®MAX 2 ultra-fine element meets the highest cleanliness standards, even at full flow.

Protection against failure:

The off-line filter includes a feature that guarantees a closed by-pass valve even at $v \leq 200 \text{ mm}^2/\text{s}$ / 930 SUS (cold start condition) within specified operating parameters.

Special design features*Housing cover:*

The cover can be opened without special auxiliary tools.

Flow control valve:

Through a pressure compensated flow control valve, the FNS off-line filters are directly connected to the high pressure pipe. The surplus volume (e.g. in circuits with fixed displacement pumps) from the high-pressure circuit is cleaned by the ultra-fine filter element.

Dirt retention valve:

At the bottom of the filter element, flow through from the inside to the outside, there is a dirt retention valve. This closes while pulling the filter element, which is hung up at the cover, out of the housing. Sedimented dirt is removed together with the filter element. Because of the cover design, the filter element change can be carried out almost without losing any oil.

Filter elements

Flow direction from the inside to the outside. The star-shaped pleating of the filter material results in:

- › large filter surfaces
- › low pressure drop
- › high dirt-holding capacities
- › particularly long maintenance intervals

Filter maintenance

By using a clogging indicator, the correct moment for maintenance is stated, what guarantees optimum utilization of the filter life.

Materials

Filter head:	Aluminum alloy
Filter housing:	Steel
Cover:	Aluminum alloy
Seals:	NBR (FPM on request)
Filter media:	EXAPOR®MAX 2 - inorganic, multi-layer microfiber web

Accessories

Water-absorbing filter elements EXAPOR®AQUA are available on request.
Electrical and / or optical clogging indicators are available on request.
For dimensions and technical data see catalog sheet 60.20.

Characteristics

Nominal flow rate

Up to 4 l/min / 1.1 gpm (see Selection Chart, column 2)
Refers to the medium flow rate of the flow control valve. With selection of the flow control valve, a sufficient surplus volume from the high-pressure circuit has to be guaranteed. If necessary, the machine manufacturer should be consulted.

Connection

Threaded port according to ISO 228 or DIN 13.
Sizes see Selection Chart, column 6
(other port threads on request)

Filter fineness

3 µm(c)
β-values according to ISO 16889
(see Selection Chart, column 4 and diagram Dx)

Dirt-holding capacity

The dirt-holding capacity values in grams from the ISO MTD test dust are in accordance with the ISO 16889 requirements (see Selection Chart, column 5).

Hydraulic fluids

Mineral oil and biodegradable fluids
(HEES and HETG, see info-sheet 00.20)

Temperature range

-30 °C ... +100 °C (temporary -40 °C ... +120 °C)
-22 °F ... +212 °F (temporary -40 °F ... +248 °F)

Viscosity at nominal flow rate

- › at operating temperature: $v < 35 \text{ mm}^2/\text{s} / 162 \text{ SUS}$
- › as starting viscosity: $v_{\text{max}} = 400 \text{ mm}^2/\text{s} / 5560 \text{ SUS}$

Operating pressure

Max. 320 bar / 4640 psi
(max. 5 bar / 73 psi without pressure compensated flow control valve)

Minimum inlet pressure at the pressure compensated flow control valve: 10 bar / 145 psi

Mounting position

Vertical, connection port at the bottom

Δp-curves for complete filters in Selection Chart, column 3

D1 Flow volume as a function of the **differential pressure** at the flow control valve at $v = 35 \text{ mm}^2/\text{s} / 162 \text{ SUS}$

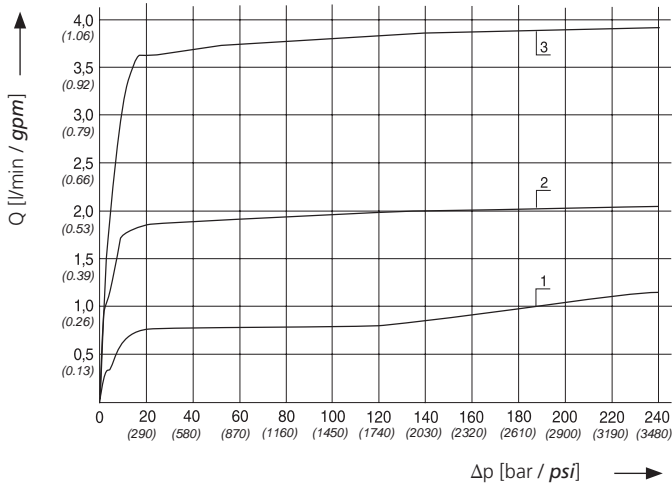

Filter fineness curves in Selection Chart, column 4

Dx Filtration ratio β as a function of particle size x obtained by the Multi-Pass Test according to ISO 16889

The abbreviations represent the following β -values resp. finenesses:

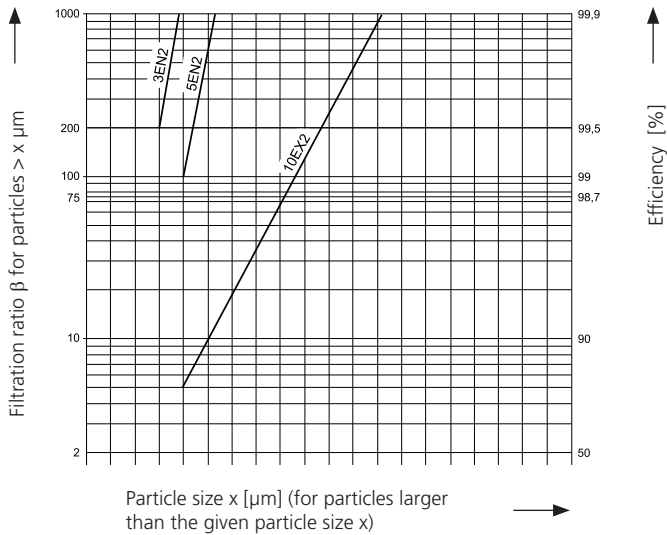

With EXAPOR®MAX2 and paper elements:

3EN2	=	$\bar{\beta}_3(c)$	= 200	EXAPOR®MAX 2
5EN2	=	$\bar{\beta}_5(c)$	= 200	EXAPOR®MAX 2
10EX2	=	$\bar{\beta}_{10}(c)$	= 200	EXAPOR®MAX 2

For special applications, finenesses differing from these curves are also available by using special composed filter media.

Selection Chart

Part No.	Nominal flow rate		Pressure drop see diagram D1 /curve no.	Filter fineness s. diagram Dx	Dirt-holding capacity	Connection A/B		Cracking pressure of by-pass	Symbol	Replacement filter element Part No.	Weight		Clogging indicator	Flow control valve	Remarks
	l/min	gpm				g	bar				psi	kg			
1	2	3	4	5	6	7	8	9	10	11	12	13			
FNS 060-163	*	*	D1 /*	3EN2	1450	G1/G1	3.5	51	1	V7.1230-153	5.2	11.5	option	option	basic unit
FNS 060-183	4	1.06	D1 /3	3E-A	130	G1/G1	3.5	51	2	Y7.1230-153	5.3	11.7	option	FNS 060.1540	
Pressure compensated flow control valve - inlet pressure min. 10 bar / 145 psi, max. 320 bar / 4640 psi:															
FNS 060.1520	1	0.26	D1 /1			G1/G $\frac{3}{4}$									–
FNS 060.1530	2	0.53	D1 /2			G1/G $\frac{3}{4}$									–
FNS 060.1540	4	1.06	D1 /3			G1/G $\frac{3}{4}$									–

* see nominal flow rate of the flow control valves

The housing of the off-line filter is designed for a max. operating pressure of 5 bar / 73 psi. To avoid back pressures, no components such as ball valves must be inserted at the housing outlet and in the continuative circuit.

For contamination monitoring, manometers or electrical pressure switches can be used.

For appropriate clogging indicators, please refer to catalog sheet 60.20.

Remarks:

- › The cut-in pressure of the pressure switch must be lower than the cracking pressure of the by-pass valve (see Selection Chart, column 7).
- › Clogging indicators and flow control valves are optionally available and will be supplied separately if ordered.
- › The off-line filters listed in this chart are standard units. If modifications are required, e.g. with water-absorbing filter elements, we kindly ask for your request.

Dimensions

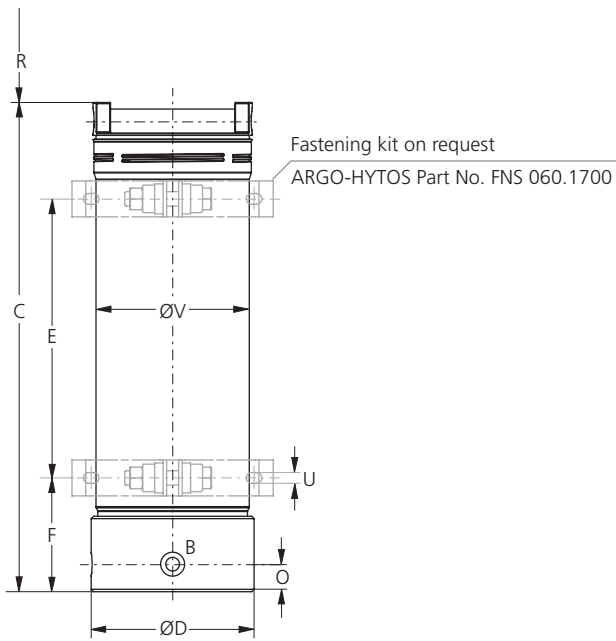
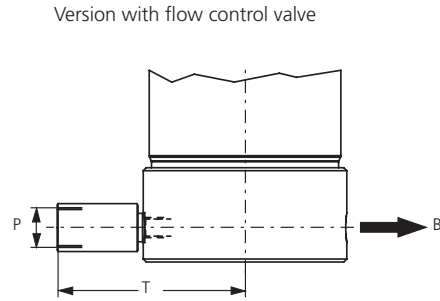
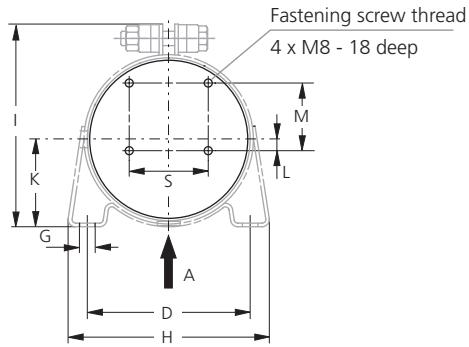

Version with manometer

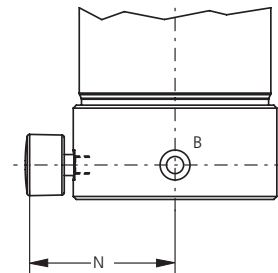

Measurements in mm

Type	A/B	C	D	E	F	G	H	I	K	L	M	N	O	P	R	S	T	U	V
FNS 060	G1	410	136	233	95	12	170	169	73	9.5	56.5	103	23	G $\frac{3}{4}$	300	66	119	9	128

Measurements in inch

Type	A/B	C	D	E	F	G	H	I	K	L	M	N	O	P	R
FNS 060	G1	16.14	5.35	9.17	3.74	0.47	6.69	6.65	2.87	0.37	2.22	4.06	0.91	G $\frac{3}{4}$	11.81

Type	S	T	U	V
FNS 060	2.60	4.69	0.35	5.04

Symbols

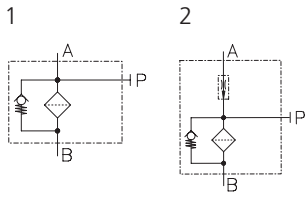

Spare Parts

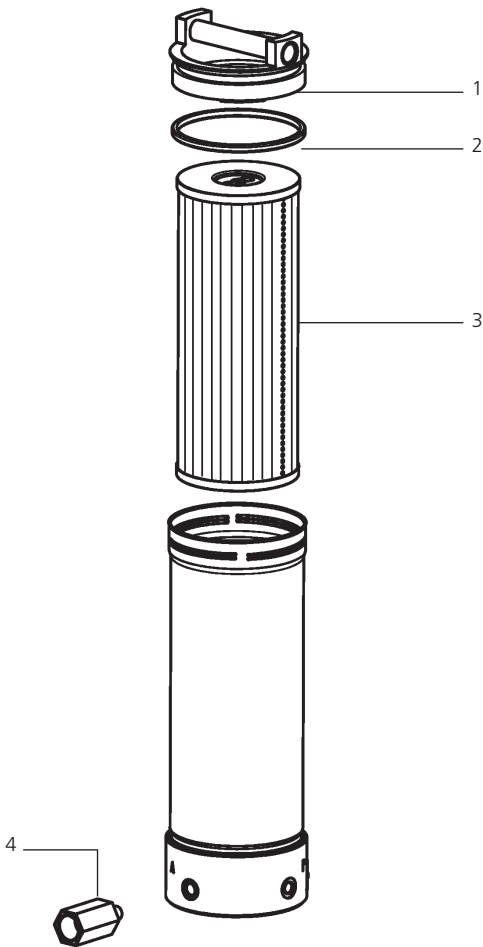

Pos.	Designation	Part No.
1	Cover	FNA 008.1250
2	O-ring	N007.1175
3	Filter element	s. Selection Chart
4	Flow control valve	s. Selection Chart

The functions of the complete filters as well as the outstanding features of the filter elements assured by ARGO-HYTOS can only be guaranteed if original ARGO-HYTOS spare parts are used.

Quality Assurance

Quality management according to DIN EN ISO 9001

To ensure constant quality in production and operation, ARGO-HYTOS filter elements undergo strict controls and tests according to the following ISO standards:

ISO 2941	Verification of collapse / burst pressure rating
ISO 2942	Verification of fabrication integrity (Bubble Point Test)
ISO 2943	Verification of material compatibility with fluids
ISO 3968	Evaluation of pressure drop versus flow characteristics
ISO 16889	Multi-Pass-Test (evaluation of filter fineness and dirt-holding capacity)
ISO 23181	Determination of resistance to flow fatigue using high viscosity fluid

Various quality controls during the production process guarantee the leak-free function and solidity of our filters.

Illustrations may sometimes differ from the original. ARGO-HYTOS is not responsible for any unintentional mistake in this specification sheet.

Off-line Filter Unit with DC motor

FNA 014

Operating pressure up to 4 bar / 58 psi · Nominal flow rate up to 14 l/min / 4.2 gpm · 24 VDC electric motor S1 duty cycle



FNA 014 Off-line Filtration Unit



EXAPOR®MAX 2 Filter Element

Description

The FNA 014 is an off-line filter unit designed for installation in hydraulic or lubrications systems. The unit can be equipped with a 24 or 12 VDC electric motor. The EXAPOR®MAX 2 ultra-fine filter element is the heart of the FNA 014. A high separation efficiency guarantees excellent fluid cleanliness levels and thereby maximum protection of the machine. Optionally, the unit can be equipped with EXAPOR® AQUA elements which remove both water and solid particles. The high dirt holding capacity of the filter elements makes the FNA 014 an economical choice for our customers.

Characteristics

Pump design

Gerotor pump

Hydraulic fluids

Mineral oil and biodegradable fluids (HEES and HETG, see info service sheet 00.20). Other fluids on request.

Temperature range of fluids

0 °C ... +65 °C / +32 °F ... +149 °F

Ambient temperature range

0 °C ... +50 °C / +32 °F ... +122 °F

Viscosity range

15 - 200 mm²/s - continuous operation
15 - 400 mm²/s - short-term operation

Operating position

Vertical, motor at the bottom

Recommended tank capacities

100 l ... 1500 l / 25 ... 400 gal

Symbols / Connections

1. Hydraulic

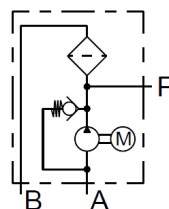

2. Electric*

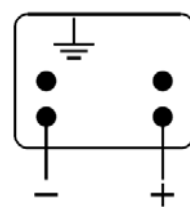

* Current consumption (tested with oil VG 46, temp. +20 °C / +68 °F):
- free flow, no. filter element: 5 A
- closed flow (by-pass valve opened): 10 A

Technical data	
Nominal flow rate	up to 14 l/min / 3.7 gpm
Operating pressure	max. 4 bar / 58 psi
Filter fineness (Bx(c) = 200 according to ISO 16889:1999)	3 µm EXAPOR®AQUA 7 µm
Dirt-holding capacity	up to 280 g
Water capacity	up to 340 ml
Electric motor*	24 VDC; 280 W; S1
Suction port (inlet)**	G $\frac{3}{4}$
Pressure port (outlet)**	G $\frac{1}{2}$
Suction height max.	1.5 m / 4.9 ft
Weight	approx. 11 kg / 24.3 lbs
Recommended clogging indicator	DG 200-16 Others: see data sheet 60.20

Order code	
FNA 014-16553	3 µm EXAPOR®MAX 2 element
FNA 014-16555	7 µm EXAPOR®AQUA element

Other versions available on request.

Spare filter element code	Fineness Bx(c) = 200	Dirt / water capacity at 14 l/min / 3.7 gpm
V7.1220-113	3 µm	280 g
V7.1220-13	5 µm	270 g
V7.1220-06	10 µm	240 g
EXAPOR®AQUA for filtration combined with dewatering		
Y7.1220-05	7 µm	120 g / 340 ml
Y7.1220-113	3 µm	190 g / 300 ml

* Version with 12 VDC motor available on request.

** Versions with UNF ports available on request.

Dimensions

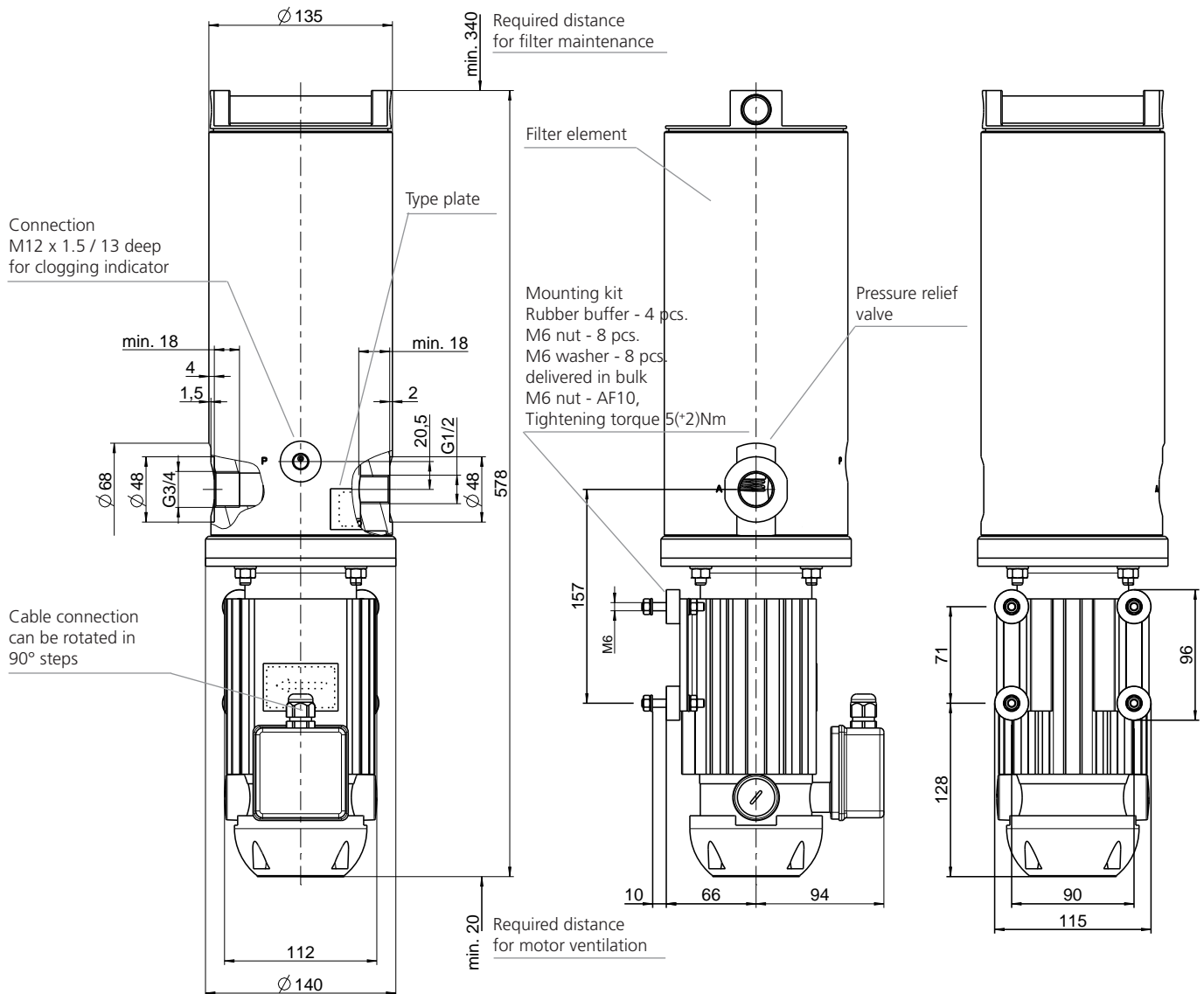

Off-line Filter Units**FNA1 008 / 016**

Operating pressure up to 4 bar / 58 psi · Nominal flow rate up to 19 l/min / 5.0 gpm



Off-line Filter Unit

Description**Application**

In the by-pass flow of hydraulic and lubrication systems.

Performance features*Protection against wear:*

By means of filter elements that meet the highest demands regarding cleanliness class and dirt-holding capacity.

Protection against failure:

By means of continuous partial filtration, excellent cleanliness classes can be achieved. Machine failures, due to contamination, are reduced, maintenance and oil change intervals are extended.

Special design features*Housing cover:*

The cover can be opened without special auxiliary tools.

Compact:

The unique cover design allows that the filter element can be changed without losing any oil. No pipes are needed except for the connection lines. The filter units feature low power consumption and minimal operational noise.

Pressure relief valve:

An integrated PRV (pressure relief valve) protects against overload.

Dirt retention valve:

At the bottom of the filter element, flow through from the inside to the outside, there is a dirt retention valve. This closes while pulling the filter element, which is hung up at the cover, out of the housing. Sedimented dirt is removed together with the filter element. Because of the cover design, the filter element change can be carried out almost without losing any oil.

Filter elements

Flow direction from the inside to the outside. The star-shaped pleating of the filter material results in:

- › large filter surfaces
- › low pressure drop
- › high dirt-holding capacities
- › particularly long maintenance intervals

Filter maintenance

By using a clogging indicator, the correct moment for maintenance is stated, what guarantees optimum utilization of the filter life.

Materials

Pump housing:	Aluminum alloy
Filter housing:	Steel
Cover:	Aluminum alloy
Seals:	NBR (FPM on request)
Filter media:	EXAPOR®MAX 2 - inorganic, multi-layer microfiber web

Accessories

With Part No. FNA 008.1700, a mounting set is available, that facilitates the fitting of incoming and outgoing pipes onto an existing filling / venting connection.

Electrical and / or optical clogging indicators may be ordered together with the off-line filter unit. For choosing the proper clogging indicator see table Clogging Indicator in the Ordering Code. A separate order of the clogging indicator is possible. For dimensions and technical data of the clogging indicators - see catalog sheet 60.30.

Hydraulic fittings and hoses for installation of the unit in the system are available on request.

For installation in filter cooling circuits, a version with by-pass valve is available on request.

Characteristics

Nominal flow rate

Up to 19 l/min at $v = 35 \text{ mm}^2/\text{s}$ /
up to 5 gpm at $v = 162 \text{ SUS}$

Viscosity range

15 - 250 mm^2/s / 70 - 1160 SUS - continuous operation
15 - 400 mm^2/s / 70 - 1860 SUS - short term operation

Off-line filter units for higher viscosities
(up to 1500 mm^2/s / 6950 SUS)
see catalog sheet FNA1HV 008 / 016 no. 80.41

Connection

Threaded port according to ISO 228
(see Ordering Code and Dimension Drawing)

Filter fineness

3 $\mu\text{m(c)}$... 10 $\mu\text{m(c)}$ for EXAPOR®MAX 2
separating solid particles
3 $\mu\text{m(c)}$... 7 $\mu\text{m(c)}$ for EXAPOR®AQUA
separating water and solid particles

Dirt-holding capacity

The dirt-holding capacity values in grams from the ISO MTD test dust are in accordance with the ISO 16889 requirements (see Ordering Code, table Filter Element).

Hydraulic fluids

Mineral oil and biodegradable fluids
(HEES and HETG, see info-sheet 00.20)

Temperature range of fluids

0 °C ... +65 °C / +32 °F ... +149 °F
(also see viscosity range)

Ambient temperature range

0 °C ... +50 °C / +32 °F ... +122 °F

Suction height

max. 1 m / 3.28 ft (unfilled)
max. 6 m / 19.69 ft (in operating condition)

Operating pressure

Max. 4 bar / 58 psi, pressure protection with pressure relief valve

Operating position

Vertical, motor at the bottom

Recommended tank capacities

FNA1 008: up to 800 l / 200 gal
FNA1 016: up to 1500 l / 400 gal

Off-line filter units for tank capacities exceeding
1500 l / 400 gal see catalog sheet FNA 045 no. 80.50.

Ordering code

Type of filter unit		Code	
Off-line filter unit		FNA1	

Nominal flow rate*		Code	
8 l/min / 2.11 gpm		008	
16 l/min / 4.23 gpm		016	

Connection port		Code	
Size	Dimensions type no.		
In: G $\frac{3}{4}$ Out: G $\frac{1}{2}$	1 or 2	G	
In: 1 $\frac{1}{16}$ -12 UN-2B Out: $\frac{3}{4}$ -16 UN-2B	3 or 4	U	

Filter element					Code	
		Fineness ($\beta=200$) Dirt-holding capacity according to ISO 16889 / water capacity		Filter element		
		FNA1 008	FNA1 016			
EXAPOR [®] MAX 2	3 μ m	490 g	280 g	V7.1220-113	V003	
EXAPOR [®] MAX 2	5 μ m	460 g	270 g	V7.1220-13	V005	
EXAPOR [®] MAX 2	10 μ m	340 g	190 g	V7.1220-06	V010	
EXAPOR [®] AQUA	7 μ m	64 g / 320 ml	38 g / 190 ml	Y7.1220-05	Y007	
EXAPOR [®] AQUA	3 μ m	45 g / 340 ml	25 g / 205 ml	Y7.1220-113	Y003	

Electric motor*					Code	
Phase(s), voltage	Frequency	Power FNA 1 008 / 016	Electric connection	Dimensions type no.		
3~400/460 VAC	50/60 Hz	0.25 / 0.45 kW	1	1 or 3	40050	
1~230 VAC	50/60 Hz	0.25 / 0.45 kW	2	2 or 4	23050	
1~110 VAC	50/60 Hz	0.25 / 0.45 kW	2	2 or 4	11050	

Clogging indicator						Code	
Type		Code of indicator	Data sheet no.	Connection	Hydraulic symbol		
Manometer	optical	DG 200-16	60.20	M12 x 1.5	1	O	
Pressure switch	electrical	DG 813-21	60.20	M12 x 1.5	2	E	
Pressure switch	optical / electrical	DG 815-12	60.20	M12 x 1.5	3	EO	
				M12 x 1.5	4	X	
Differential pressure clogging indicator	optical	DG 042-01	60.30	Flange	5	OD	
	electrical	DG 041-32	60.30	Flange	6	ED	
	electrical + optical	DG 041-32 + DG 041.1200	60.30	Flange	7	EOD	
				Flange	8	XD	

* Indications at 50 Hz. At 60 Hz, the value increases by approx. 20%.
For version with DC motor, 24 or 12 V see data sheet FNA 014 no. 80.35

Dimensions

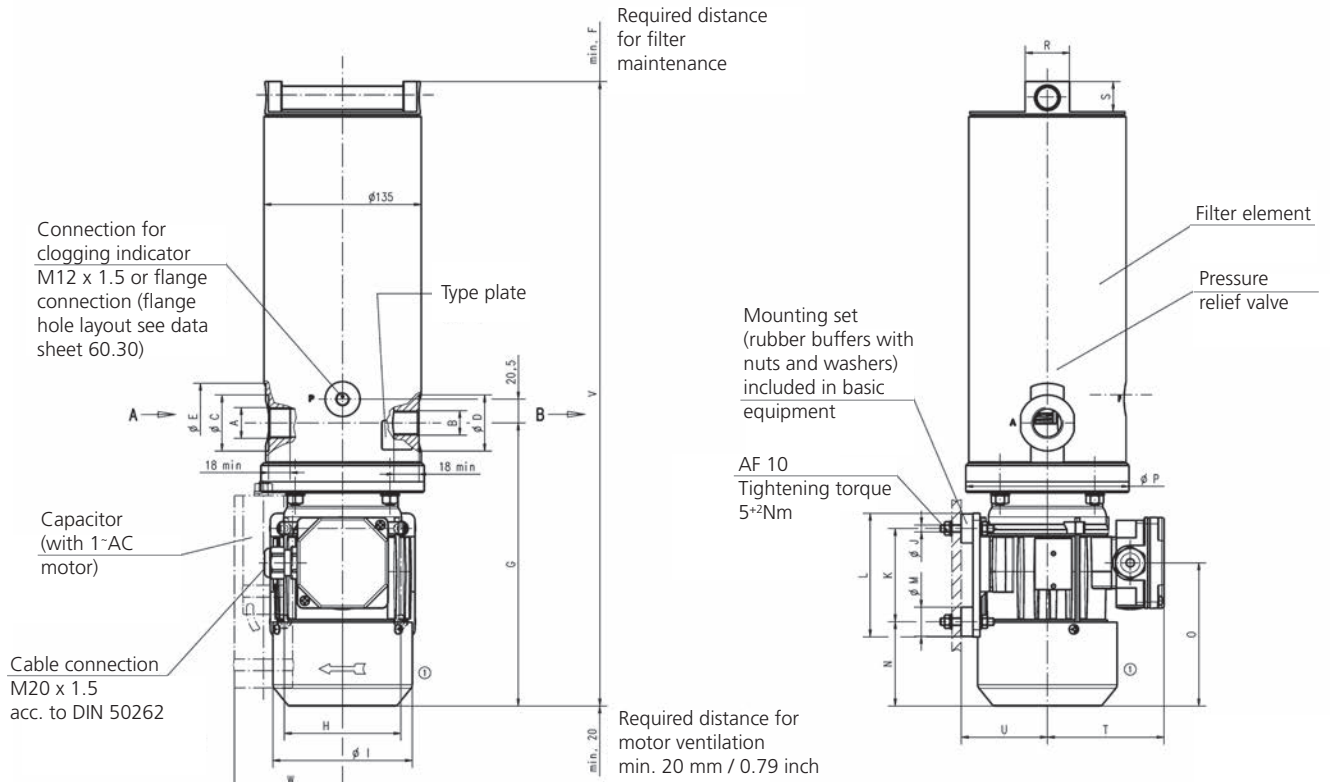

Measurements in mm

Type*	A	B	C	D	E	F	G	H	I	J	K	L	M
1	G ^{3/4}	G ^{1/2}	48	48	68	340	243	100	120	M6	80	106	25
2	G ^{3/4}	G ^{1/2}	48	48	68	340	243	100	120	M6	80	106	25
3	1 ^{1/16} -12 UN-2B	3/4-16 UNF-2B	41	30	68	340	243	100	120	M6	80	106	25
4	1 ^{1/16} -12 UN-2B	3/4-16 UNF-2B	41	30	68	340	243	100	120	M6	80	106	25

Type*	N	O	P	R	S	T	U	V	W				
1	72	123	140	38	26	101	74	535	-				
2	72	123	140	38	26	101	74	535	100				
3	72	123	140	38	26	101	74	535	-				
4	72	123	140	38	26	101	74	535	100				

Measurements in inch

Type*	A	B	C	D	E	F	G	H	I	J	K	L	M
1	G ^{3/4}	G ^{1/2}	1.89	1.89	2.68	13.39	9.57	3.94	4.72	M6	3.15	4.17	0.98
2	G ^{3/4}	G ^{1/2}	1.89	1.89	2.68	13.39	9.57	3.94	4.72	M6	3.15	4.17	0.98
3	1 ^{1/16} -12 UN-2B	3/4-16 UNF-2B	1.61	1.18	2.68	13.39	9.57	3.94	4.72	M6	3.15	4.17	0.98
4	1 ^{1/16} -12 UN-2B	3/4-16 UNF-2B	1.61	1.18	2.68	13.39	9.57	3.94	4.72	M6	3.15	4.17	0.98

Type*	N	O	P	R	S	T	U	V	W				
1	2.83	4.84	5.51	1.50	1.02	3.98	2.91	21.06	-				
2	2.83	4.84	5.51	1.50	1.02	3.98	2.91	21.06	3.94				
3	2.83	4.84	5.51	1.50	1.02	3.98	2.91	21.06	-				
4	2.83	4.84	5.51	1.50	1.02	3.98	2.91	21.06	3.94				

*Type see Ordering Code (Dimensions Type no.)

Hydraulic symbols

1

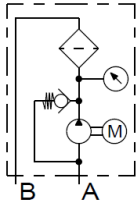

2

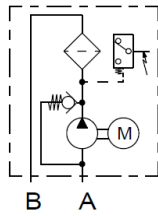

3

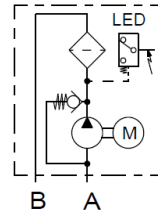

4

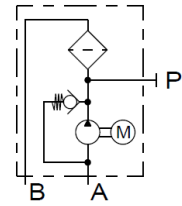

5

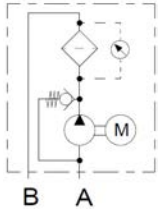

6

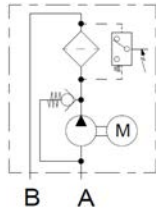

7

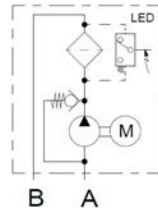

8

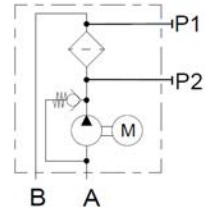

Electric connections

1

Delta connection

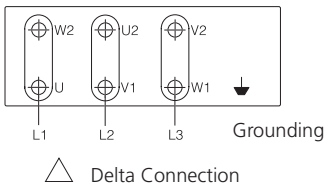

Star connection

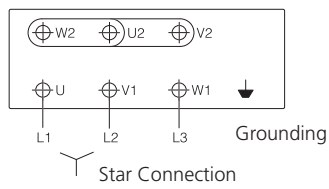

2

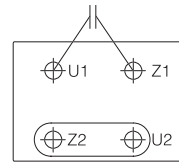

Order example

FNA1 016G-V003/23050-E

Off-line filter unit with nominal flow rate 16 l/min / 4.23 gpm, inlet port G $\frac{3}{4}$, outlet port G $\frac{1}{2}$, EXAPOR[®]MAX 2 filter element, fineness 3 μ m, electric motor 1~230 VAC and electric clogging indicator

Dimensions type: 2

Remarks:

Combinations listed in this data sheet are standard units. If modifications are required, we kindly ask for your request.

Illustrations may sometimes differ from the original. ARGO-HYTOS is not responsible for any unintentional mistake in this specification sheet.

Off-line Filter Units for High Viscosities
FNA1HV 008 / 016

Viscosity range 15-1500 mm²/s / 70-6950 SUS · Operating pressure up to 6 bar / 87 psi · Nominal flow rate up to 16 l/min / 4.23 gpm



FNA1HV Off-line Filter Unit

Description
Application

In the by-pass flow of hydraulic and lubrication systems. The unit is designed to operate with viscosities between 15 and 1500 mm²/s / 70 and 6950 SUS. This allows, for example, the filtration of transmission fluids and high viscosity oils even at low temperatures.

Performance features
Protection against wear:

By means of filter elements that meet the highest demands regarding cleanliness class and dirt-holding capacity.

Protection against failure:

By means of continuous partial filtration, excellent cleanliness classes can be achieved. Machine failures, due to contamination, are reduced, maintenance and oil change intervals are extended.

Special design features
Housing cover:

The cover can be opened without special auxiliary tools.

Compact:

The unique cover design allows that the filter element can be changed without losing any oil. No pipes are needed except for the connection lines. The filter units feature low power consumption and minimal operational noise.

Pressure relief valve:

An integrated PRV (pressure relief valve) protects against overload.

Dirt retention valve:

At the bottom of the filter element, flow through from the inside to the outside, there is a dirt retention valve. This closes while pulling the filter element, which is hung up at the cover, out of the housing. Sedimented dirt is removed together with the filter element. Because of the cover design, the filter element change can be carried out almost without losing any oil.

Filter elements

Flow direction from the inside to the outside. The star-shaped pleating of the filter material results in:

- › large filter surfaces
- › low pressure drop
- › high dirt-holding capacities
- › particularly long maintenance intervals

Filter maintenance

By using a clogging indicator, the correct moment for maintenance is stated, what guarantees optimum utilization of the filter life.

Materials

Pump housing: Aluminum alloy
Filter housing: Aluminum alloy, powder painted RAL 5015
Cover: Aluminum alloy
Seals: NBR (FPM on request)
Filter media: EXAPOR®MAX 2 - inorganic, multi-layer microfiber web
EXAPOR®AQUA - combination of water absorbing filter layers and inorganic, multi-layer microfiber web

Remarks

Other colors of the filter housing are available on request.

Accessories

With Part No. FNA 008.1700, a mounting set is available, that facilitates the fitting of incoming and outgoing pipes onto an existing filling / venting connection.

Electrical and / or optical clogging indicators may be ordered together with the off-line filter unit. For choosing the proper clogging indicator see table Clogging Indicator in the Ordering Code. A separate order of the clogging indicator is possible. For dimensions and technical data of the clogging indicators see catalog sheet 60.30.

Hydraulic fittings and hoses for installation of the unit in the system are available on request.

Characteristics

Nominal flow rate

Up to 16 l/min / 4.23 gpm

Viscosity range

15 - 1500 mm²/s / 70 - 6950 SUS - continuous operation
15 - 2000 mm²/s / 70 - 9260 SUS - short term operation

Connection

Threaded port according to ISO 228
(see Dimension Drawing)

Filter fineness

3 µm(c) ... 10 µm(c) for EXAPOR®MAX 2
separating solid particles
3 µm(c) ... 7 µm(c) for EXAPOR®AQUA
separating water and solid particles

Dirt-holding capacity

The dirt-holding capacity values in grams from the ISO MTD test dust are in accordance with the ISO 16889 requirements (see Ordering Code, table Filter Element).

Hydraulic fluids

Mineral oil and biodegradable fluids
(HEES and HETG, see info-sheet 00.20)

Temperature range of fluids

0 °C ... +65 °C / +32 °F ... +149 °F
(also see viscosity range)

Ambient temperature range

0 °C ... +50 °C / +32 °F ... +122 °F

Maximum suction height

1.5 m / 4.9 ft

Operating pressure

Max. 6 bar / 87 psi, pressure protection with pressure relief valve

Operating position

Vertical, motor at the bottom

Weight

Approx. 11 kg / 24.3 lbs

Recommended tank capacities

Up to 1500 l / 400 gal

Ordering code

FNA1HV

- / -

Type of filter unit	Code
Off-line filter unit, high viscosity version	FNA1HV

Nominal flow rate*	Code
8 l/min / 2.11 gpm	008
16 l/min / 4.23 gpm	016

Connection ports	Code
In: G1 Out: G $\frac{3}{4}$	G
In: 1 $\frac{5}{16}$ -12 UN-2B Out: 1 $\frac{1}{16}$ -12 UN-2B	U

Filter element					Code
		Fineness ($\beta=200$) Dirt-holding capacity according to ISO 16889 / water capacity		Spare filter element code	
		FNAHV1 008	FNAHV1 016		
EXAPOR [®] MAX 2	3 μ m	490 g	280 g	V7.1220-113	V003
EXAPOR [®] MAX 2	5 μ m	460 g	270 g	V7.1220-13	V005
EXAPOR [®] MAX 2	10 μ m	340 g	190 g	V7.1220-06	V010
EXAPOR [®] AQUA	7 μ m	64 g / 320 ml	38 g / 190 ml	Y7.1220-05	Y007
EXAPOR [®] AQUA	3 μ m	45 g / 340 ml	25 g / 205 ml	Y7.1220-113	Y003

Electric motor*				Code
Phase(s), voltage	Frequency	Power FNA1HV 008 / 016	Elec. connection	
3~400/460 VAC	50/60 Hz	0.37 / 0.55 kW	1	40050
1~230 VAC	50/60 Hz	0.37 / 0.55 kW	2	23050

Clogging indicator						Code
Type		Code of indicator	Connection	Datasheet number	Hydraulic symbol	
Differential pressure clogging indicator	optical	DG 042-04	Flange	60.30	1	OD
	electrical	DG 041-32	Flange	60.30	2	ED
	electrical + optical	DG 041-32 DG 041.1200	Flange	60.30	3	EOD
Without clogging indicator					4	XD

* Indications at 50 Hz. At 60 Hz, the value increases by approx. 20%.

Order example:

FNA1HV 008G-V003/40050ED off-line filter unit, high viscosity version, nominal flow rate 8 l/min / 2.11 gpm, with inlet port G1, outlet port G $\frac{3}{4}$, equipped with 3 μ m filter element, 3~phase electric motor and electrical differential pressure clogging indicator.

Remarks:

Combinations listed in this ordering code are standard units. If modifications are required, we kindly ask for your request.

Dimensions

Weight approx. 11 kg / 24.3 lbs

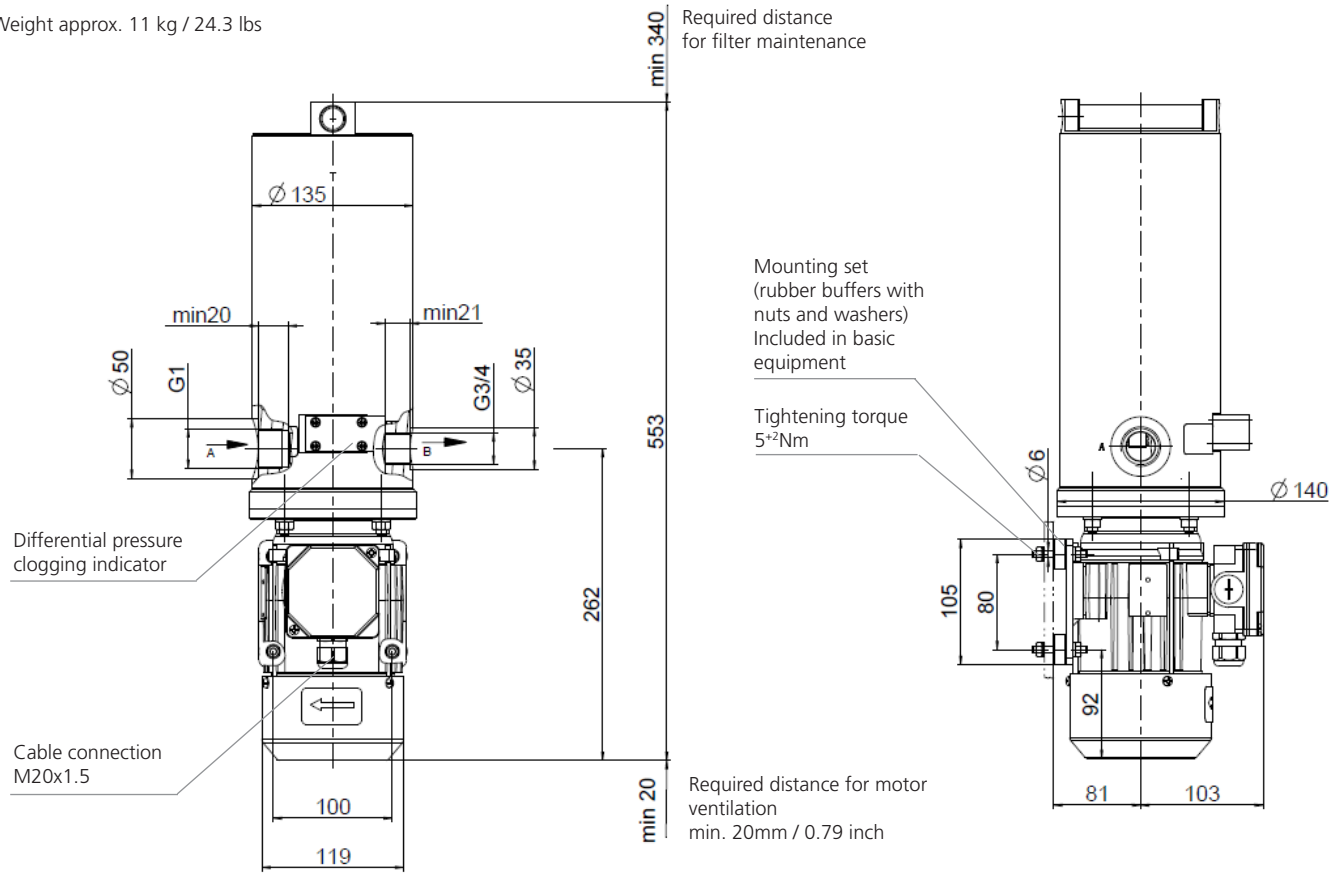

Hydraulic symbol

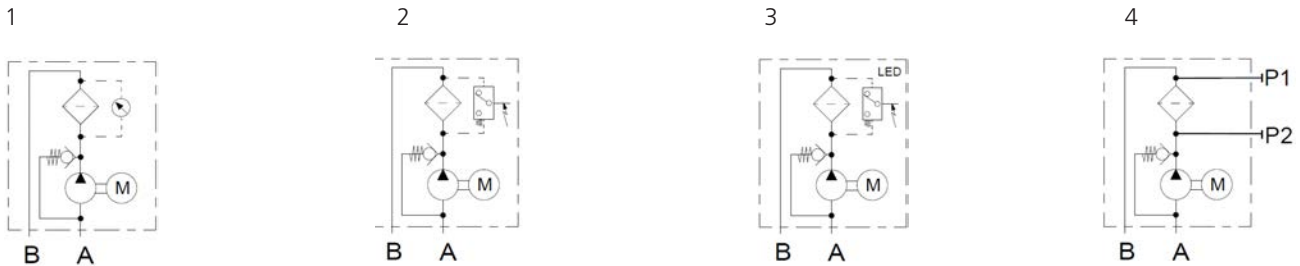

Electric connections

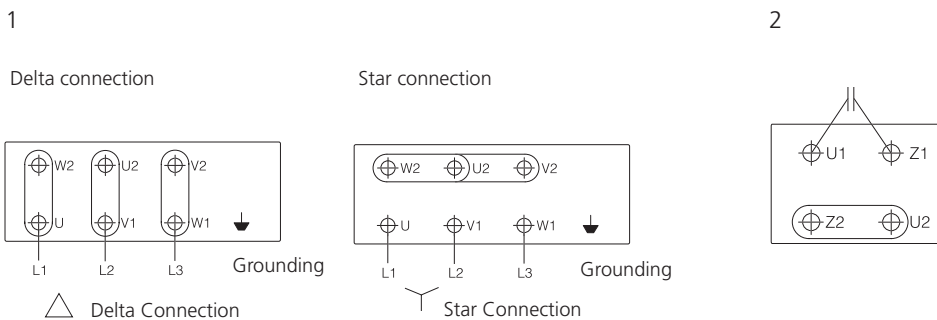

Illustrations may sometimes differ from the original. ARGO-HYTOS is not responsible for any unintentional mistake in this specification sheet.

Off-line Filter Unit
FNA 040-553

Nominal flow rate up to 40 l/min / 10.6 gpm · Operating pressure up to 8 bar / 116 psi



Off-line Filter Unit FNA 040-553

Description
FNA 040-553

The FNA 040-553 can be used as an additional off-line filter unit or as a self-contained system filter for continuous improvement of the oil cleanliness. The operation of the unit is independent of the working cycles of the machine. Thus, the filter element can be changed without interrupting the working process.

Compact and efficient

The compact design allows installation in restricted spaces. With 40 l/min / 10.6 gpm, the oil is continuously pumped over a fine filter, allowing the highest cleanliness levels to be reached, even with larger tank volumes.

Dirt-holding capacity

The dirt-holding capacity values in grams from the ISO MTD test dust are in accordance with the ISO 16889 requirements.

Hydraulic fluids

Mineral oil and biodegradable fluids (HEES and HETG, see info sheet 00.20).
Other fluids on request.

Technical data	
Nominal flow rate	40 l/min / 10.6 gpm
Filter fineness	$\bar{\beta}_{3(c)} = 200^*$
Dirt-holding capacity	380 g*
Electric drive	3~400 V, 0.75 KW, n = 1400 min ⁻¹ at 50 Hz, n = 1700 min ⁻¹ at 60 Hz
Weight	approx. 30 kg / 66 lbs
Temperature range of fluids / viscosity range	0 °C ... +60 °C +32 °F ... +140 °F
Continuous operation min.	15 mm ² /s / 70 SUS
Continuous operation max.	400 mm ² /s / 1860 SUS
Ambient temperature range	0 °C ... +50 °C +32 °F ... +122 °F
Operating pressure	Max. 8 bar / 116 psi
Clogging indicator	Electrical differential pressure indicator

*test dust ISO MTD according to ISO 16889

Order No.

FNA 040-553

Replacement filter element Order No.

V7.1230-153



Compact and ready to connect

The FNA 040-553 comes ready to connect, with filter element.

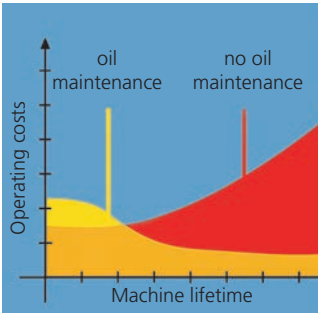

Economical

Das FNA 040-553 Off-line Filter Unit offers protection that can extend the lifetime of machinery. This protection gives a direct return on investment through extended service intervals and increased machine availability.



User-friendly filter element change

The filter element can be removed from the housing together with the cover. The dirt retention valve ensures that solid particle sediment is completely removed with the filter element.

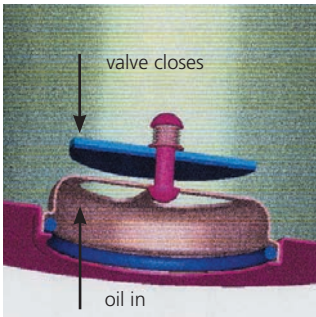

Maintenance-free filter housing thanks to a unique filter element technique

Fluid flows through the element from the inside to the outside. The built-in dirt retention valve closes automatically when the element is removed, ensuring that all dirt is removed from the housing together with the element.

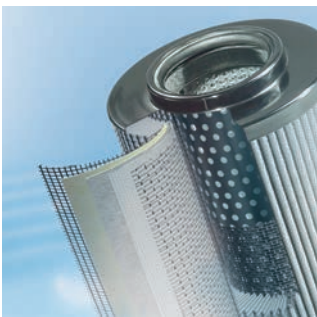

Quality in detail

The EXAPOR®MAX 2 ultra-fine element is the heart of the FNA 040. High cleanliness levels protect the system from contamination when filling with oil.

The tubing of the pressure control valve to the tank is effected by the user!

Dimensions

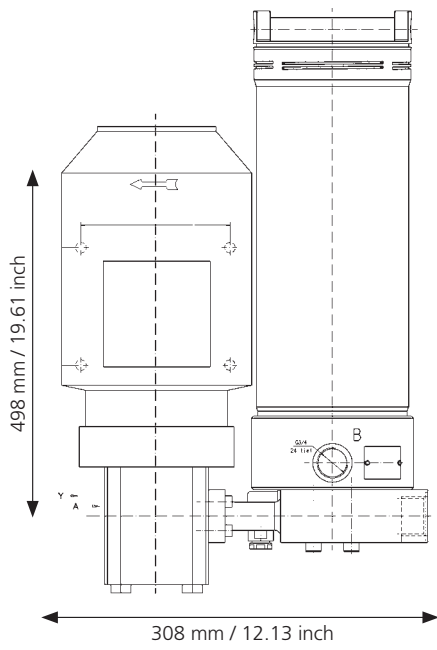

Hydraulic symbol

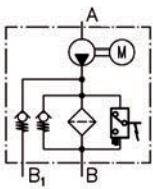

Off-line Filter Unit
FNA 045

Operating pressure up to 7 bar / 101 psi · Nominal flow rate up to 45 l/min / 12 gpm



Off-line Filter Unit FNA 045

Description
Application

In the by-pass flow of hydraulic and lubrication systems.

Performance features
Protection against wear:

The EXAPOR®MAX 2 ultra-fine element meets the highest cleanliness standards, even at full flow.

Protection against failure:

 The off-line filter includes a feature that guarantees a closed by-pass valve even at $v \leq 200 \text{ mm}^2/\text{s}$ / 930 SUS (cold start condition) within specified operating parameters.

Special design features
Housing cover:

Fold-out handle parts at the cover facilitate the opening.

Compact:

The filter housing, the internal gear pump and the electric motor are screwed together to form a unit. No pipes are needed except for the connection lines. The filter units feature low power consumption and minimal operational noise.

Pressure relief valve:

An integrated PRV (pressure relief valve) protects against overload.

Dirt retention valve:

At the bottom of the filter element, flow through from the inside to the outside, there is a dirt retention valve. This closes while pulling the filter element, which is hung up at the cover, out of the housing. Sedimented dirt is removed together with the filter element. Because of the cover design, the filter element change can be carried out almost without losing any oil.

Filter elements

Flow direction from the inside to the outside. The star-shaped pleating of the filter material results in:

- › large filter surfaces
- › low pressure drop
- › high dirt-holding capacities
- › particularly long maintenance intervals

Filter maintenance

By using a clogging indicator, the correct moment for maintenance is stated, what guarantees optimum utilization of the filter life.

Materials

Pump and filter housing: Aluminum alloy
Cover: Aluminum alloy
Seals: NBR (FPM on request)
Filter media: EXAPOR®MAX 2 - inorganic, multi-layer microfiber web

Accessories

Water-absorbing filter elements EXAPOR®AQUA are available on request.
Electrical and / or optical clogging indicators are available on request – with either one or two switching points resp. temperature suppression.
For dimensions and technical data of the clogging indicators, please refer to catalog sheet 60.30.

Characteristics

Nominal flow rate

Up to 45 l/min at $v = 35 \text{ mm}^2/\text{s}$ /
up to 12 gpm at $v = 162 \text{ SUS}$
(see Selection Chart, column 2)

Connection

Threaded port according to ISO 228 or DIN 13.
Sizes see Selection Chart, column 9 and 10

Filter fineness

3 $\mu\text{m(c)}$... 10 $\mu\text{m(c)}$
 β -values according to ISO 16889
(see Selection Chart, column 4 and Diagram Dx)

Dirt-holding capacity

The dirt-holding capacity values in grams from the ISO MTD test dust are in accordance with the ISO 16889 requirements (see Selection Chart, column 4).

Hydraulic fluids

Mineral oil and biodegradable fluids
(HEES and HETG, see info-sheet 00.20)

Temperature range of fluids

0 °C ... +65 °C / +32 °F ... +149 °F
(also see viscosity range)

Ambient temperature range

0 °C ... +50 °C / +32 °F ... +122 °F

Viscosity range

Electro motor air cooled type of protection: IP 55	Continuous operation min.	Continuous operation max.	Short-term max.
3 ~ 400 V / 460 V	15 mm ² /s / 70 SUS	600 mm ² /s / 2790 SUS	800 mm ² /s / 3720 SUS
1 ~ 230 V	15 mm ² /s / 70 SUS	600 mm ² /s / 2790 SUS	800 mm ² /s / 3720 SUS

Maximum suction height

max. 2 m / 6.56 ft (unfilled)
max. 6 m / 19.69 ft (in operating condition)

Operating pressure

Max. 7 bar / 101 psi,
pressure protection with pressure relief valve

Operating position

Vertical, pump block at the bottom

Recommended tank capacities

From 500 l up
For off-line filter units for smaller tank capacities
see catalog sheet 80.40.

Δp-curves for complete filters in Selection Chart, column 3

Dx Filtration ratio β as a function of particle size x obtained by the Multi-Pass Test according to ISO 16889

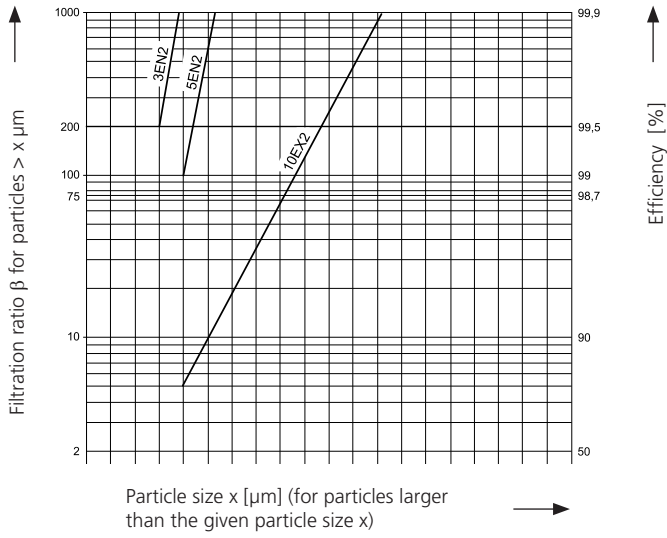

The abbreviations represent the following β -values resp. finenesses:

With EXAPOR®MAX2 elements:

3EN2	=	$\bar{\beta}_{3(c)}$	=	200	EXAPOR®MAX2
5EN2	=	$\bar{\beta}_{5(c)}$	=	200	EXAPOR®MAX2
10EX2	=	$\bar{\beta}_{10(c)}$	=	200	EXAPOR®MAX2

For special applications, finenesses differing from these curves are also available by using special composed filter media.

Selection Chart

Part No.	Nominal flow rate		Filter fineness s. diagram Dx	Dirt-holding capacity	E-motor operating voltage	E-motor operating frequency (max.)	E-motor power (max.)	Engine speed at 50 Hz (max.)
	l/min	gpm						
1	2		3	4	5	6	7	8
FNA 045-1553	45*	12*	3EN2	1,950	1 ~ 230 V	50(60)*	1.1*	1,500
FNA 045-1153	45*	12*	5EN2	1,980	1 ~ 230 V	50(60)*	1.1*	1,500
FNA 045-4553	45*	12*	3EN2	1,950	3 ~ 400/460 V	50(60)*	1.1*	1,500
FNA 045-4153	45*	12*	5EN2	1,980	3 ~ 400/460 V	50(60)*	1.1*	1,500

* Indications at 50 Hz. At 60 Hz, the value increases by approx. 20%.

Part No.	Connection A Inlet	Connection B Outlet	Max. operating pressure (PRV)		Symbols hydraulic	Symbols electric	Replacement filter element Part No.	Clogging indicator
			bar	psi				
1	9	10	11		12	13	14	15
FNA 045-1553	G1¼	G1	7	101	1	3	V7.1560-103	optional
FNA 045-1153	G1¼	G1	7	101	1	3	V7.1560-03	optional
FNA 045-4553	G1¼	G1	7	101	1	1, 2	V7.1560-103	optional
FNA 045-4153	G1¼	G1	7	101	1	1, 2	V7.1560-03	optional

Optical or electrical indicators are available to monitor the clogging condition of the element. If the indicator should be already mounted onto the filter head, use the abbreviation "M" behind the part number of the indicator. The printed order acknowledgements show both items separately.

Order example: The filter FNA 045-1553 has to be supplied with optical clogging indicator - response pressure 2.0 bar / 29 psi.

Order example: _____ **FNA 045-1553** / _____ **DG 042-01** **M**
Part No. (Basic unit) _____ **Mounted**
Clogging indicator _____

For appropriate clogging indicators see catalog sheet 60.30.

Remarks:

- › In case of an increasing operating frequency, the pump delivery volume will increase as well.
- › The filter units listed in this chart are standard units. If modifications are required, e.g. with water-absorbing filter elements, we kindly ask for your request.

Dimensions

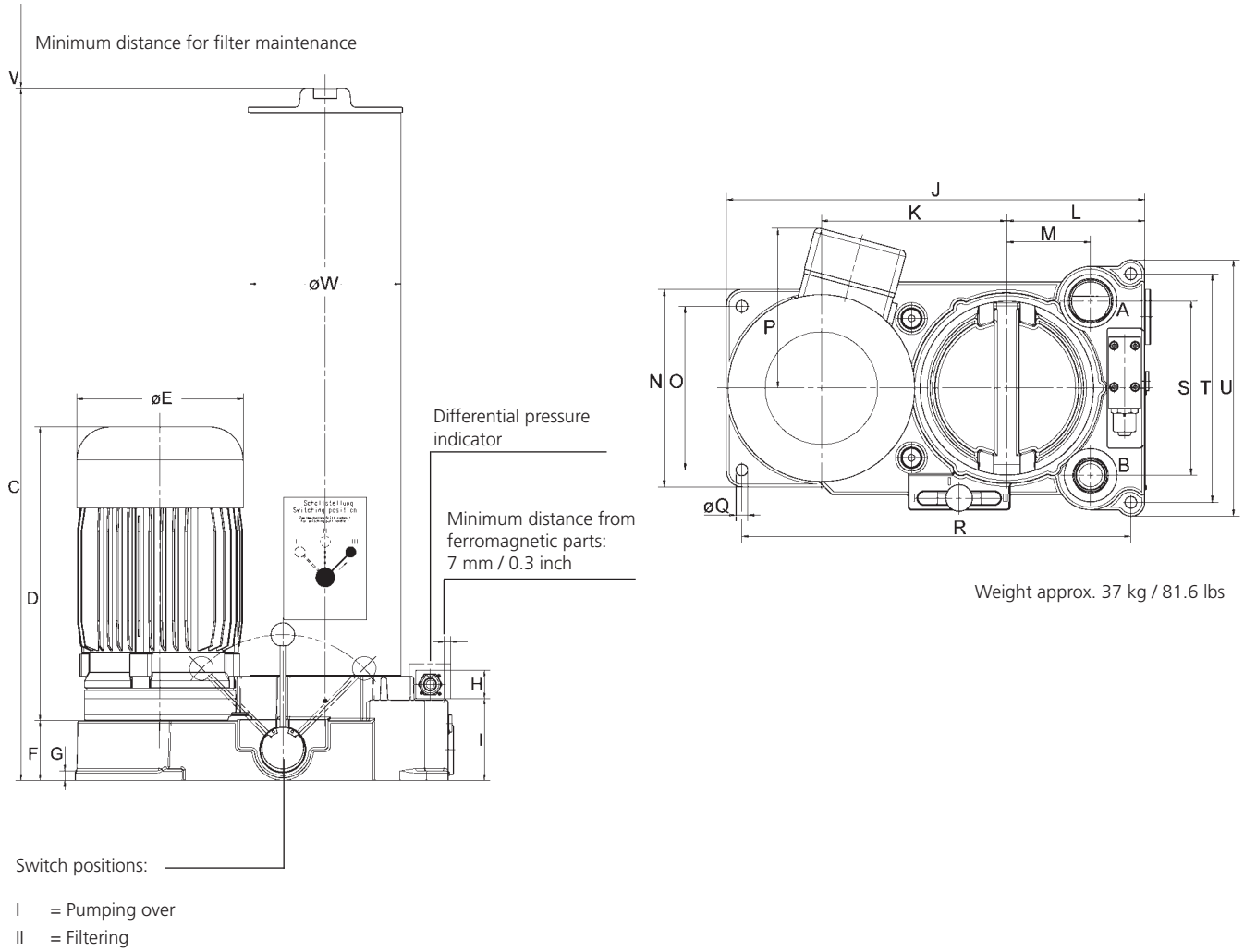

Measurements in mm

Type	A	B	C	D	E	F	G	H	I	J	K	L	M	N	O
FNA 045	G1¼	G1	735	312	176	63	10	30	87	395	175	130	79	186	154

Type	P	Q	R	S	T	U	V	W							
FNA 045	150	11	367	164	215	241	700	160							

Measurements in inch

Type	A	B	C	D	E	F	G	H	I	J	K	L	M	N	O
FNA 045	G1¼	G1	28.94	12.28	6.93	2.48	0.39	1.18	3.43	15.55	6.89	5.12	3.11	7.32	6.06

Type	P	Q	R	S	T	U	V	W							
FNA 045	5.91	0.43	14.45	6.46	8.46	9.49	27.56	6.30							

Hydraulic symbol

1

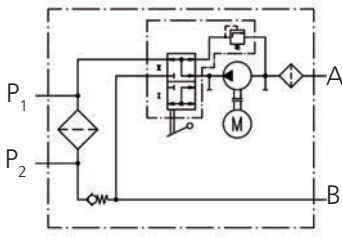

Electric connections

1

Connections

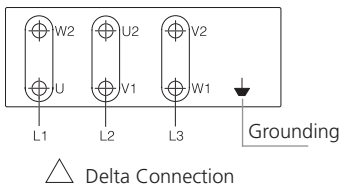

2

Connections

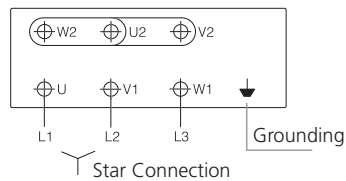

3

Connections

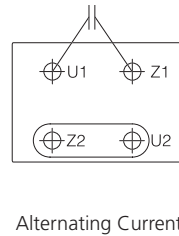

Quality Assurance

Quality management according to DIN EN ISO 9001

To ensure constant quality in production and operation, ARGO-HYTOS filter elements undergo strict controls and tests according to the following ISO standards:

ISO 2941	Verification of collapse / burst pressure rating
ISO 2942	Verification of fabrication integrity (Bubble Point Test)
ISO 2943	Verification of material compatibility with fluids
ISO 3968	Evaluation of pressure drop versus flow characteristics
ISO 16889	Multi-Pass-Test (evaluation of filter fineness and dirt-holding capacity)
ISO 23181	Determination of resistance to flow fatigue using high viscosity fluid

Various quality controls during the production process guarantee the leak-free function and solidity of our filters.

Illustrations may sometimes differ from the original. ARGO-HYTOS is not responsible for any unintentional mistake in this specification sheet.

Off-line Filter Unit
FNAPC1 045

With oil condition monitoring · Nominal flow rate up to 45 l/min / 12 gpm · Operating pressure up to 7 bar / 101 psi



Off-line Filter Unit FNAPC1 045



OPCom Particle Monitor

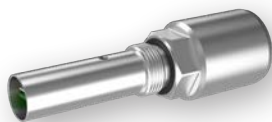

LubCos Humidity / Oil Condition Sensor

Description
Application

In the by-pass flow of hydraulic and lubrication systems.

Performance features
Protection against wear:

The EXAPOR®MAX 2 ultra-fine element meets the highest cleanliness standards, even at full flow. A high separation efficiency and excellent dirt holding capacity guarantee maximum protection of the machine and make the FNAPC 1 045 an economical choice for our customers.

Filtration with oil condition monitoring:

In addition to efficient filtration, the FNAPC 1 045 provides continuous oil condition monitoring. This functionality significantly increases the reliability and productivity of the hydraulic system.

The unit can be equipped with one or two sensors:

The OPCom particle sensor permanently monitors the current oil cleanliness class.

The second sensor can be supplied in two versions.

The humidity sensor LubCos H₂O measures the temperature and the relative humidity of the oil.

In the version with LubCos H₂O+ II, the relative humidity, temperature, permittivity and conductivity are issued. This sensor is prepared for continuous determination of the oil condition.

Thereby damages can be detected early or avoided completely.

This offers the opportunity to prevent machine failures and to extend maintenance and oil change intervals.

Special design features
Housing cover:

Fold-out handles at the cover facilitate the opening.

Compact:

The filter housing, the internal gear pump and the electric motor are screwed together to form one unit. Apart from the connecting lines to the sensor block and the suction/pressure hose, no pipes are needed.

Dirt retention valve:

At the bottom of the filter element, flow through from the inside to the outside, there is a dirt retention valve. This closes while pulling the filter element, which is hung up at the cover, out of the housing. Sedimented dirt is removed together with the filter element. Because of the cover design, the filter element change can be carried out almost without losing any oil.

Switching valve:

The switching valve is used to switch between the basic modes of operation: "filtering" and "pumping without filtering".

Filter elements

Flow direction from the inside to the outside. The star-shaped pleating of the filter material results in:

- › large filter surfaces
- › low pressure drop
- › high dirt-holding capacities
- › particularly long maintenance intervals

Materials

Pump: Cast iron, steel
Filter housing: Aluminum alloy, painted RAL 5015
Cover: Aluminum alloy
Seals: NBR (FPM on request)
Filter media: EXAPOR®MAX 2 - inorganic, multi-layer microfiber web
EXAPOR®AQUA - combination of water absorbing filter layers and inorganic, multi-layer microfiber web

Remarks

Other colors of the filter housing are available on request.

Accessories

Electrical and / or optical clogging indicators may be ordered together with the off-line filter unit. For choosing the proper clogging indicator see table "Clogging Indicator" in the Ordering Code. A separate ordering of the clogging indicator is possible.

For dimensions and technical data of the clogging indicator, please refer to catalog sheets 60.20 and 60.30.

Characteristics

Nominal flow rate

Up to 45 l/min at $v = 35 \text{ mm}^2/\text{s}$ /
up to 12 gpm at $v = 162 \text{ SUS}$

Connection

Threaded port according to ISO 228
(see Dimensions - drawing)

Filter fineness

3 $\mu\text{m(c)}$... 10 $\mu\text{m(c)}$ with EXAPOR®MAX 2
separating solid particles
7 $\mu\text{m(c)}$ with EXAPOR®AQUA
separating water and solid particles

Dirt-holding capacity

The dirt-holding capacity values in grams from the ISO MTD test dust are in accordance with the ISO 16889 requirements (see Ordering Code, table Filter Element).

Hydraulic fluids

Mineral oil and biodegradable fluids
(HEES and HETG, see info-sheet 00.20)

Temperature range of fluids

0 °C ... +65 °C / +32 °F ... +149 °F
(also see viscosity range)

Ambient temperature range

0 °C ... +50 °C / +32 °F ... +122 °F

Viscosity range*

Motor voltage	Continuous operation min.	Continuous operation max.	Short-term operation max.
3 ~ 400 V / 460 V	15 mm ² /s / 70 SUS	250 mm ² /s / 1160 SUS	800 mm ² /s / 3720 SUS
1 ~ 230 V	15 mm ² /s / 70 SUS	250 mm ² /s / 1160 SUS	800 mm ² /s / 3720 SUS

* The maximum continuous viscosity for the filter unit itself is 600 mm²/s / 2790 SUS; an exact measurement of the oil cleanliness class is possible within a viscosity range from 15 mm²/s to 250 mm²/s / 70 SUS to 1160 SUS.

Maximum suction height

2 m / 6.6 ft - first use / unfilled
6 m / 20 ft - operating status

Operating pressure

Max. 7 bar / 101 psi,
pressure protection with pressure relief valve

Operating position

Vertical, pump block at the bottom

Recommended tank capacities

From 500 l up
For off-line filter units for smaller tank capacities see catalog sheet 80.40.

FNAPC1 045 / - -

Type of filter unit	Code
Off-line filter unit with OPCom particle monitor*	FNAPC1

Nominal flow rate	Code
45 l/min / 11.9 gpm**	045

Filter element				Spare filter element code	Code
	Fineness ($\beta=200$) Dirt-holding capacity for nom. flow 45 l/min / 11.9 gpm	Water capacity			
EXAPOR®MAX 2	3 μm	1950 g	-	V7.1560-103	V003
EXAPOR®MAX 2	5 μm	1980 g	-	V7.1560-03	V005
EXAPOR®MAX 2	10 μm	2020 g	-	V7.1560-06	V010
EXAPOR®AQUA	7 μm	590 g	1520 ml	Y7.1560-05	Y007

Electric motor					Code
Phase(s), voltage	Frequency	Power	Rated current	Electrical connection	
3~400/460 VAC	50/60 Hz	1.1 kW**	4.8/2.8 A T/Y	1	40050
1~230 VAC	50/60 Hz	1.1 kW**	7.2 A	2	23050

Clogging indicator					Code
Type		Code of indicator	Connection	Datasheet number	
Differential pressure clogging indicator	optical	DG 042-04	Flange	60.30	OD
	electrical	DG 041-32	Flange	60.30	ED
	electrical+optical	DG 041-32 DG 041.1200	Flange	60.30	EOD

Oil condition sensor			Code
Measured parameter	Code of sensor	Datasheet number	
Relative humidity Temperature	LubCos H ₂ O	100.00	H
Relative humidity Temperature Relative dielectric number Conductivity	LubCos H ₂ O+ II	100.05	HC
Without oil condition sensor			x

Type of monitoring	Hydraulic symbol	Code
Upstream (before filter)	1	
Downstream (after filter)	2	D

* The OPCom particle monitor is factory fitted in each version of the filter unit. The customer only needs to enter the oil condition sensor in the order code.
 ** Indications at 50 Hz. At 60 Hz, the value increases by approx. 20 %.

Order example:

FNAPC1 045V003/40050-ED-H off-line filter unit with OPCom particle monitor, 3 μm filter element, 3~phase electric motor, electrical differential pressure clogging indicator, humidity sensor LubCos H₂O. Monitoring type: before filter.

Remarks:

Combinations listed in this ordering code are standard units. If modifications are required, we kindly ask for your request. For preferred types (available in short time), please refer to the table on the last page of this data sheet.

Dimensions

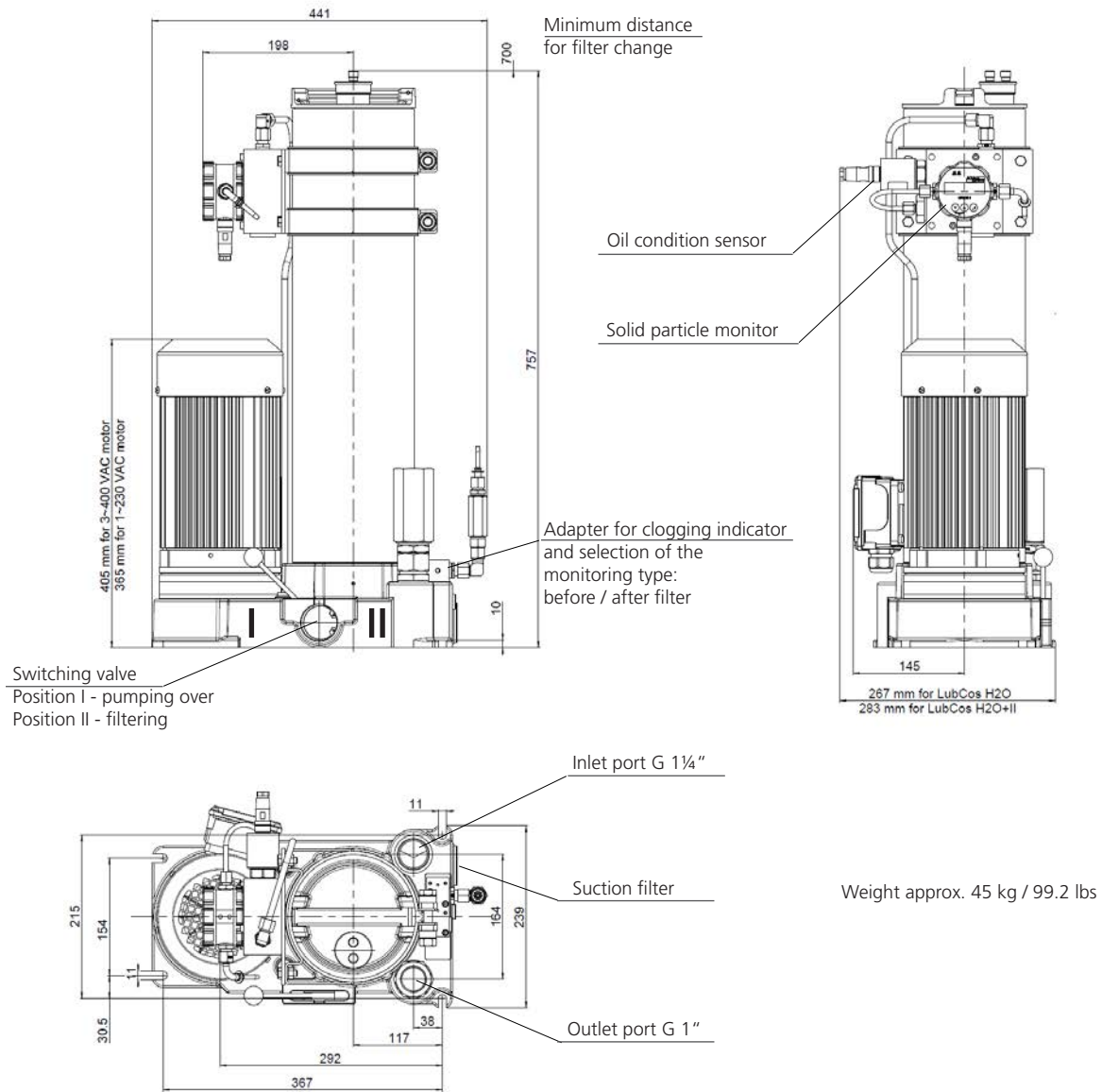

Hydraulic symbols

1 - Measurement before filter

2 - Measurement after filter

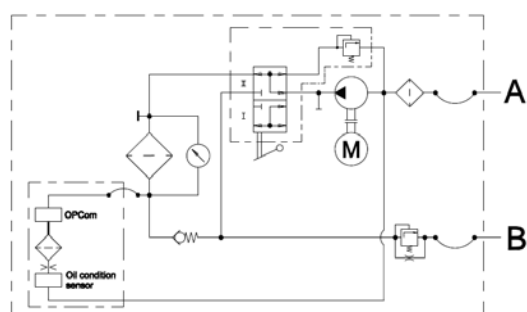
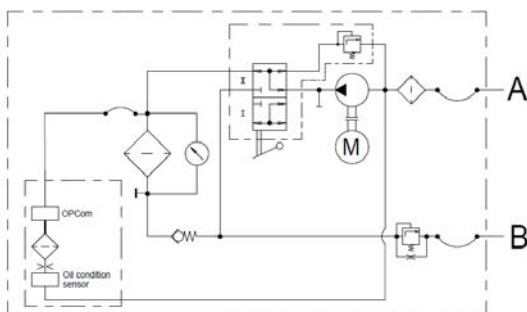

Electric connections

1

400/460 VAC, 3~phase motor

Delta connection

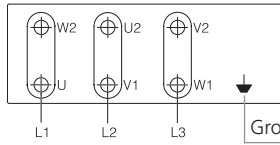

△ Delta Connection

Star connection

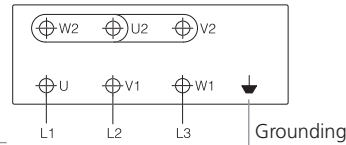

Y Star Connection

2

230 VAC, 1~phase motor

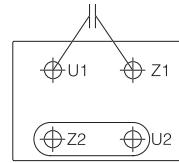

Preferred types

Order code	Filter fineness ($\beta=200$)	Dirt-holding capacity	Replacement filter element	Motor	Clogging indicator	Oil condition sensor	Hydraulic symbol	SAP number
FNAPC1-045V003/23050-OD-H	3 μm	1950 g	V7.1560-103	1~230 VAC	Optical	LubCos H ₂ O	1	42707200
FNAPC1-045V003/40050-OD-H	3 μm	1950 g	V7.1560-103	3~400/460 VAC	Optical	LubCos H ₂ O	1	42707000
FNAPC1-045V003/23050-ED-H	3 μm	1950 g	V7.1560-103	1~230 VAC	Electrical	LubCos H ₂ O	1	42707100
FNAPC1-045V003/40050-ED-H	3 μm	1950 g	V7.1560-103	3~400/460 VAC	Electrical	LubCos H ₂ O	1	42707300

Quality Assurance

Quality management according to DIN EN ISO 9001

To ensure constant quality in production and operation, ARGO-HYTOS filter elements undergo strict controls and tests according to the following ISO standards:

- ISO 2941 Verification of collapse / burst pressure rating
- ISO 2942 Verification of fabrication integrity (Bubble Point Test)
- ISO 2943 Verification of material compatibility with fluids
- ISO 3968 Evaluation of pressure drop versus flow characteristics
- ISO 16889 Multi-Pass-Test (evaluation of filter fineness and dirt-holding capacity)
- ISO 23181 Determination of resistance to flow fatigue using high viscosity fluid

Various quality controls during the production process guarantee the leak-free function and solidity of our filters.

Illustrations may sometimes differ from the original. ARGO-HYTOS is not responsible for any unintentional mistake in this specification sheet.

Off-line Filter Unit
FNU 008

Operating pressure up to 4 bar / 58 psi · Nominal flow rate up to 8 l/min / 2.1 gpm



Off-line Filter Unit FNU 008

Description
Application

In the by-pass flow of hydraulic and lubrication systems.

Performance features
Protection against wear:

The EXAPOR®MAX 2 ultra-fine element meets the highest cleanliness standards, even at full flow.

Protection against failure:

 The off-line filter includes a feature that guarantees a closed by-pass valve even at $v \leq 200 \text{ mm}^2/\text{s}$ / 930 SUS (cold start condition) within specified operating parameters.

Special design features
Pressure relief valve:

An integrated PRV (pressure relief valve) protects against overload.

Filter elements

Flow direction from the inside to the outside. The star-shaped pleating of the filter material results in:

- › large filter surfaces
- › low pressure drop
- › high dirt-holding capacities
- › particularly long maintenance intervals

Filter maintenance

By using a clogging indicator, the correct moment for maintenance is stated, what guarantees optimum utilization of the filter life.

Materials

Pump housing:	Aluminum alloy
Filter housing:	Aluminum alloy
Cover:	Aluminum alloy
Seals:	NBR (Viton on request)
Filter media:	EXAPOR®MAX 2 - inorganic, multi-layer microfiber web

Accessories

Water-absorbing filter elements EXAPOR®AQUA are available on request.

With Part No. FNA 008.1700, a mounting set is available, that facilitates the fitting of incoming and outgoing pipes onto an existing filling / venting connection.

Characteristics

Nominal flow rate

Up to 8 l/min (50 Hz) at $v = 35 \text{ mm}^2/\text{s}$
 up to 2.1 gpm (50 HZ) at $v = 162 \text{ SUS}$
 (see Selection Chart, column 2)

Connection

Threaded port according to ISO 228 or DIN 13.
 Sizes see Selection Chart, column 9 and 10

Filter fineness

5 $\mu\text{m(c)}$
 β -values according to ISO 16889
 (see Selection Chart, column 3 and Diagram Dx)
 (other filter finenesses on request)

Dirt-holding capacity

The dirt-holding capacity values in grams from the ISO MTD test dust are in accordance with the ISO 16889 requirements (see Selection Chart, column 4).

Hydraulic fluids

Mineral oil and biodegradable fluids
 (HEES and HETG, see info-sheet 00.20)

Temperature range of fluids

0 °C ... +65 °C / +32 °F ... +149 °F
 (also see viscosity range)

Ambient temperature range

0 °C ... +50 °C / +32 °F ... +122 °F

Viscosity Range

Electro motor air cooled type of protection: IP 55	Continuous operation min.	Continuous operation max.	Short-term max.
3 ~ 400/690 V 50 (60) Hz	15 mm ² /s / 70 SUS	1200 mm ² /s / 5560 SUS	1500 mm ² /s / 6950 SUS

Tank volume

Approx. 2.4 l / 0.6 gal

Maximum suction height

1.0 m / 3.3 ft (unfilled / first use)
 6.0 m / 19.7 ft (operation condition)

Operating pressure

Max. 4 bar / 58 psi, pressure protection with pressure relief valve; cracking pressure see Selection Chart, column 11

Operating position

Vertical, motor at the top

Recommended tank capacities

FNU 008: up to 800 l / 211 gal

Diagrams

Filter fineness curves in Selection Chart, column 3

Dx Filtration ratio β as a function of particle size x obtained by the Multi-Pass Test according to ISO 16889

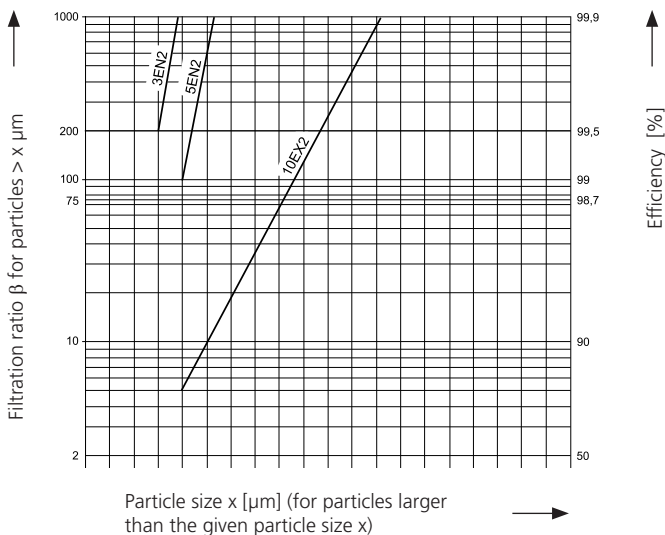

The abbreviations represent the following β -values resp. finenesses:

With EXAPOR[®]MAX2 elements:

3EN2 = $\bar{\beta}_{3(c)} = 200$ EXAPOR[®]MAX 2
 5EN2 = $\bar{\beta}_{5(c)} = 200$ EXAPOR[®]MAX 2
 10EX2 = $\bar{\beta}_{10(c)} = 200$ EXAPOR[®]MAX 2

For special applications, finenesses differing from these curves are also available by using special composed filter media.

Selection Chart

Part No.	Nominal flow rate		Filter fineness s. diagram Dx		E-motor operating voltage	E-motor operating frequency (max.)	E-motor power (max.)	Engine speed at 50 Hz (max.)	Connection A Inlet	Connection B Outlet
	l/min	gpm		g						
1	2	3	4	5	6	7	8	9	10	
FNU 008-653	8	2.1	5EN2	140	3 ~ 400 / 690 V	50 (60)	0.37 (0.43)*	1350 (1600)*	G1	G1

* Indications at 50 Hz. At 60 Hz the value increases by approx. 20 %

Part No.	Cracking pressure of by-pass		Symbols hydraulic	Symbols electric	Measurements, Type No.	Replacement filter element Part No.	Clogging indicator	Remarks
	bar	psi						
	11	12	13	14	15	16	17	
FNU 008-653	4	58	1	1, 2	1	V7.1220-13	optical	DG 842-01

Remarks:

The filter unit listed in this chart is a standard unit. If modifications are required, e.g. with water-absorbing filter elements, pipe extensions, mounting set or 60 Hz motor, we kindly ask for your request.

Dimensions

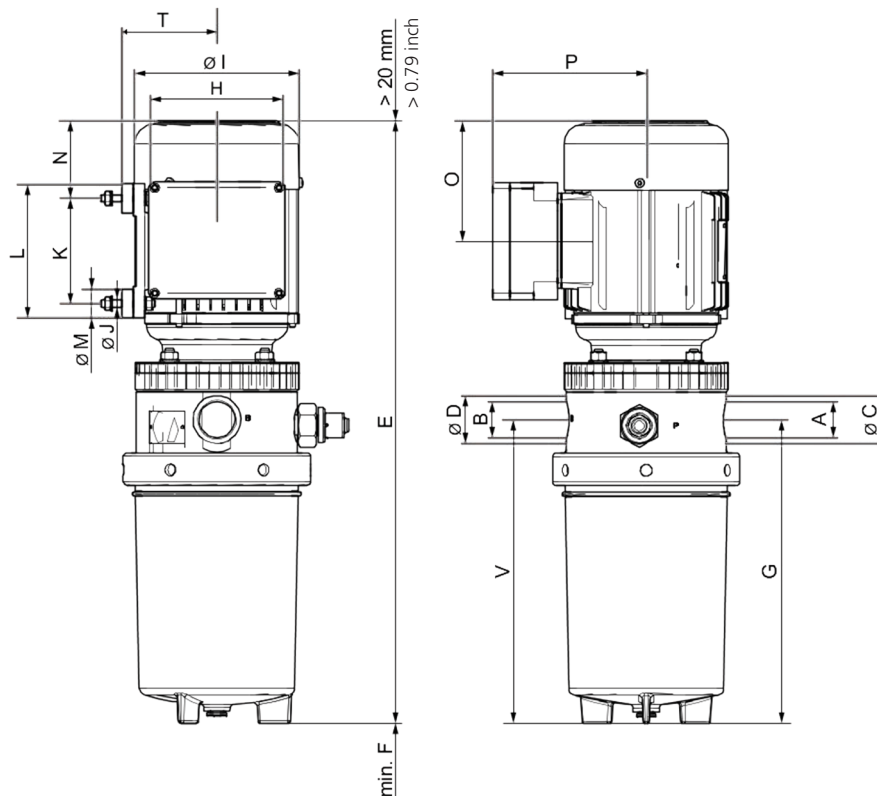

Measurements in mm

Type	A	B	C	D	E	F	G	H	I	J	K	L	M	N	O	T	U	V
FNU 008	G1"	G1"	41	41	515	60	261	261	141	M6	90	115	25	66.5	102.5	131	81	261

Measurements in inch

Type	A	B	C	D	E	F	G	H	I	J	K	L	M	N
FNU 008	G1"	G1"	1.61	1.61	28.28	2.36	10.28	10.28	5.55	M6	3.54	4.53	0.98	2.62

Type	O	T	U	V										
FNU 008	4.04	5.16	3.19	10.28										

Hydraulic symbol

1

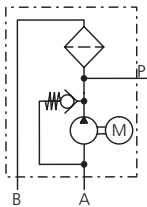

Electric connections

1

Connections

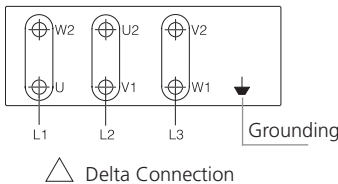

2

Connections

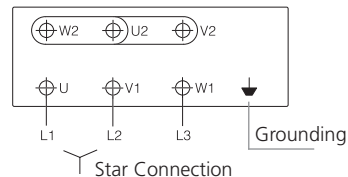

3

Connections

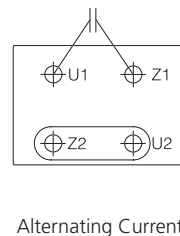

Quality Assurance

Quality management according to DIN EN ISO 9001

To ensure constant quality in production and operation, ARGO-HYTOS filter elements undergo strict controls and tests according to the following ISO standards:

ISO 2941	Verification of collapse / burst pressure rating
ISO 2942	Verification of fabrication integrity (Bubble Point Test)
ISO 2943	Verification of material compatibility with fluids
ISO 3968	Evaluation of pressure drop versus flow characteristics
ISO 16889	Multi-Pass-Test (evaluation of filter fineness and dirt-holding capacity)
ISO 23181	Determination of resistance to flow fatigue using high viscosity fluid

Various quality controls during the production process guarantee the leak-free function and solidity of our filters.

Illustrations may sometimes differ from the original. ARGO-HYTOS is not responsible for any unintentional mistake in this specification sheet.

Oil Service Unit**Compact Filter Pack CFP 03**

Ultra-light and compact · Multi-purpose system · Ergonomic design · Simplifies servicing of small power packs



Oil Service Unit CFP



Suction-return Adapter

- › Exclusive solution for small tanks
- › Perfect device for maintenance services
- › Weight only 7.8 kg / 17.3 lbs
- › Filter elements EXAPOR®MAX 2
- › Electric motor with switch
- › Smart suction-return adapter

Description**Maintenance of small power packs**

The CFP is a multi-purpose off-line filter unit, designed for servicing small power packs on a daily basis, not only to be used during start-up or a breakdown.

Thanks to its characteristics, the CFP fills the gap in the market as a first unit designed not only for filling but also for cleaning of hydraulic systems.

Ideal service equipment

The compact size and low weight make the device easily transportable from machine to machine without needing any extra transport aids.

The CFP can be used in systems where other devices are not applicable: in machines with difficult access to the oil tank or when working at height.

Dirt-holding capacity

The dirt-holding capacity values in grams from the ISO MTD test dust are in accordance with the ISO 16889 requirements.

Multi-purpose system

The CFP unit can be used for transferring oils, filling of systems with filtered oil or for off-line filtration. Off-line filtration is possible even in systems where only one connection port is available. The special suction-return adapter allows both the suction and the pressure hose to be connected to the tank (for example via the ventilating filter port).

Application examples

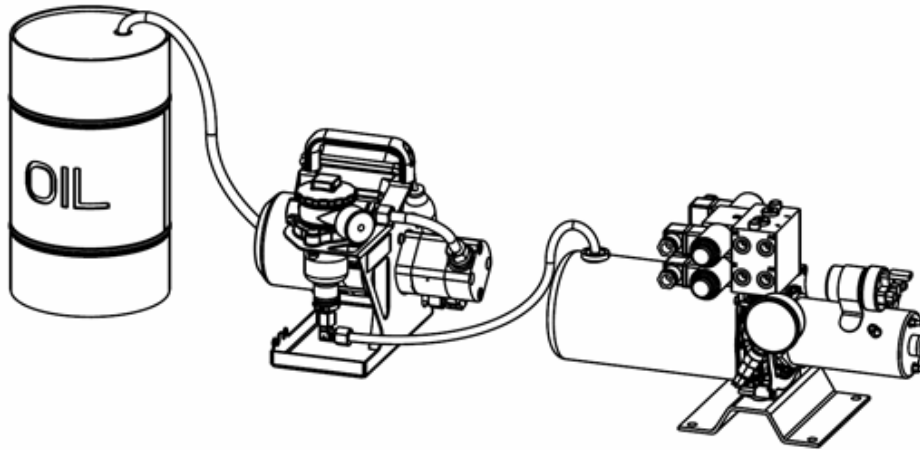

Application example 1:
Oil transfer, filling of the small power pack with fresh oil.

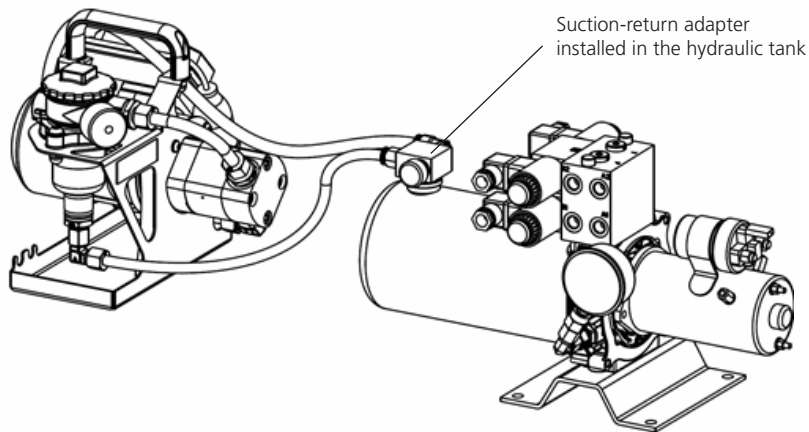

Application example 2:
Service of hydraulic systems. Off-line filtration at small power packs with only one available connection port.
Suction-return adapter installed in the ventilating filter port.

Characteristics

Hydraulic connection

Hoses:

Suction hose DN12, length 2 m / 6.6 ft
Pressure hose DN8, length 2 m / 6.6 ft
Free end of hoses closed by protective caps

Electrical connection

Electric motor, air cooled fan with ON/OFF switch

Cable: length 2.5 m / 8.2 ft
Voltages: 1 ~ 230 V AC / 50/60 Hz
1 ~ 110 V AC / 50/60 Hz
Protection class: IP 54

Pump design

External gear pump with suction strainer installed in the suction port

Operating and transport position

Upright

Hydraulic fluids

Mineral oil and biodegradable fluids
Motor oils (see info sheet 00.20)
Other fluids on request

Temperature range of fluids

0 °C ... +60 °C / +32 °F ... +140 °F

Ambient temperature range

0 °C ... +50 °C / +32 °F ... +122 °F

Viscosity range

10 - 300 mm²/s - continuous operation without adapter
10 - 170 mm²/s - continuous operation with adapter

Selection Chart

	Order No. CFP 03-13	Order No. CFP 03-16	Order No. CFP 03-18	Order No. CFP 03-131
Nominal flow rate at v = 35 mm ² /s / 162 SUS	3 l/min* / 0.79 gpm*	3 l/min* / 0.79 gpm*	3 l/min* / 0.79 gpm*	3 l/min* / 0.79 gpm*
Filter fineness (Bx(c) = 200 according to ISO 16889:1999)	5 µm	10 µm	16 µm	5 µm
Dirt holding capacity	15 g	15 g	11 g	15 g
E-Motor operating voltage	1 ~ 230 V AC	1 ~ 230 V AC	1 ~ 230 V AC	1 ~ 110 V AC
E-Motor operating frequency	50/60 Hz	50/60 Hz	50/60 Hz	50/60 Hz
E-Motor power	0.06 kW*	0.06 kW*	0.06 kW	0.06 kW*
Electric plug	Type E/F	Type E/F	Type E/F	NEMA 5-15 (type B)
Length of suction hose	2 m / 6.6 ft	2 m / 6.6 ft	2 m / 6.6 ft	2 m / 6.6 ft
Length of pressure hose	2 m / 6.6 ft	2 m / 6.6 ft	2 m / 6.6 ft	2 m / 6.6 ft
Suction height max.	2.5 m / 8.2 ft	2.5 m / 8.2 ft	2.5 m / 8.2 ft	2.5 m / 8.2 ft
Operating pressure max.	3.5 bar / 50.8 psi	3.5 bar / 50.8 psi	3.5 bar / 50.8 psi	3.5 bar / 50.8 psi
Hydraulic symbol	1	1	1	1
Replacement element Order no.	V3.0510-53	V3.0510-56	V3.0510-58	V3.0510-53
Cracking pressure of by-pass	2.5 bar / 36.3 psi	2.5 bar / 36.3 psi	2.5 bar / 36.3 psi	2.5 bar / 36.3 psi
Clogging indicator	Manometer	Manometer	Manometer	Manometer
Weight	7.8 kg / 17.3 lbs	7.8 kg / 17.3 lbs	7.8 kg / 17.3 lbs	7.8 kg / 17.3 lbs

* Indications at 50 Hz. At 60 Hz the value increases by approx. 20 %.

Accessories:

- › Suction-return adapter CFP-A-09/05

On request:

- › Customized versions
- › Other electric plugs
- › Hose extensions
- › Filter elements with other finenesses
- › Adapter with other length of suction and return hose
- › Connecting fitting G½", M22 x 1.5 (or other customized threads) for installation of the suction-return adapter in plastic tanks

Dimensions

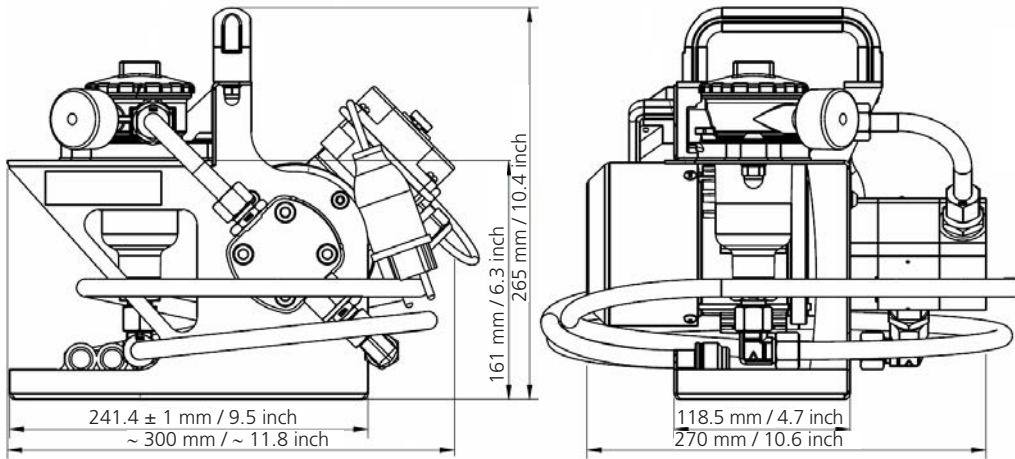

Basic device

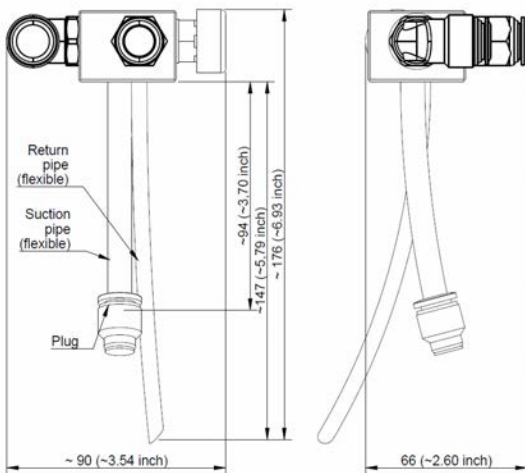

Suction-return adapter

Hydraulic Symbol

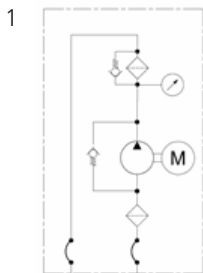

Quality Assurance

Quality management according to DIN EN ISO 9001

To ensure constant quality in production and operation, ARGO-HYTOS filter elements undergo strict controls and tests according to the following ISO standards:

- ISO 2941 Verification of collapse / burst pressure rating
- ISO 2942 Verification of fabrication integrity (Bubble Point Test)
- ISO 2943 Verification of material compatibility with fluids
- ISO 3968 Evaluation of pressure drop versus flow characteristics
- ISO 16889 Multi-Pass-Test (evaluation of filter fineness and dirt-holding capacity)
- ISO 23181 Determination of resistance to flow fatigue using high viscosity fluid

Various quality controls during the production process guarantee the leak-free function and solidity of our filters.

Illustrations may sometimes differ from the original. ARGO-HYTOS is not responsible for any unintentional mistake in this specification sheet.

Oil Service Units**FA1 / FA1HV 008**

Easy filling and cleaning · Compact design · Comfortable handling · Wide viscosity range



Oil Service Unit FA1 008

Description**FA1 008 – quick, simple and compact**

With the Oil Service Unit FA 008, hydraulic and lubricating systems can be easily filled or cleaned.

The high viscosity version FA1HV is designed to operate with viscosities between 15 and 1500 mm²/s / 70-6950 SUS. This allows, for example, the filtration of transmission fluids and high viscosity oils even at low temperatures.

Protection of components through ultra-fine filtration

The EXAPOR[®]MAX 2 ultra-fine elements are the heart of the ARGO-HYTOS filtering units FA1 008. High separation efficiencies guarantee excellent cleanliness levels and thereby highest protection of components. The high dirt holding capacity of the EXAPOR[®]MAX 2 ultra-fine elements allows economic operation of the FA1 008.

Characteristics**Nominal flow rate**

Up to 8 l/min / 2.11 gpm

Viscosity range (continuous operation)**FA1:** 15 mm²/s / 70 SUS up to 250 mm²/s / 1175 SUS**FA1HV:** 15 mm²/s / 70 SUS up to 1500 mm²/s / 6950 SUS**Operating pressure****FA1:** max. 4 bar / 58 psi**FA1HV:** max. 6 bar / 87 psi**Hydraulic fluids**

Mineral and biodegradable oils. Other fluids on request.

Temperature range of fluids

0 °C ... +65 °C / +32 °F ... +149 °F (also see viscosity range)

Ambient temperature range

0 °C ... +50 °C / +32 °F ... +122 °F

Maximum suction height

1.5 m / 4.9 ft

Operating position

Vertical, motor at the bottom

Weight

approx. 18 kg / 39.7 lbs

Recommended tank capacities

Up to 800 l / 200 gal



Compact design

The compact design allows easy access to the oil tank. FA1 008 comes ready to connect, with hose packages.

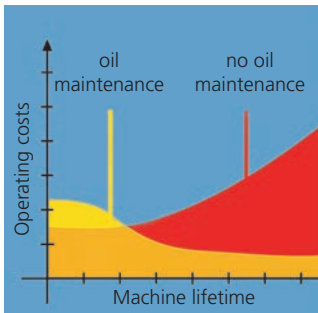

Economical

The FA1 008 Oil Service Unit offers protection that can extend the lifetime of machinery. This protection gives a direct return on investment through extended service intervals and increased machine availability.



User-friendly filter element change

The filter element can be removed from the housing together with the cover. The dirt retention valve ensures that solid particle sediment is completely removed with the filter element.

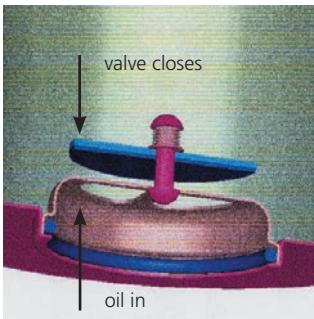

Maintenance-free filter housing due to a clever filter element technique

Fluid flows through the element from the inside to the outside. The built-in dirt retention valve closes automatically when the element is removed, ensuring that all dirt is removed from the housing with the element.

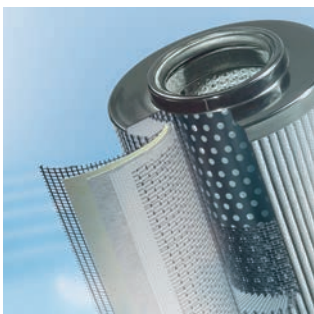

Quality in detail

The EXAPOR[®]MAX 2 fine element is the heart of the FA1 008. High cleanliness levels protect the hydraulic system against contamination during the oil filling process.

Ordering code

008

/

-

Type of unit	Code
Oil service unit - standard version	FA1
Oil service unit - high viscosity version	FA1HV

Nominal flow rate	Code
8 l/min / 2.11 gpm*	008

Filter element					Code
	Fineness ($\beta=200$) Dirt-holding capacity according to ISO 16889		Water capacity	Spare filter element	
EXAPOR®MAX 2	3 μm	490 g	-	V7.1220-113	V003
EXAPOR®MAX 2	5 μm	460 g	-	V7.1220-13	V005
EXAPOR®MAX 2	10 μm	340 g	-	V7.1220-06	V010
EXAPOR®AQUA	7 μm	64 g	320 ml	Y7.1220-05	Y007
EXAPOR®AQUA	3 μm	45 g	340 ml	Y7.1220-113	Y003

Electric motor					Code
Phase(s), voltage	Frequency	Power FA1	Power FA1HV	Electric plug	
1~230 VAC	50/60 Hz	0.25 kW*	0.37 kW*	1	23050
3~400/460 VAC	50/60 Hz	0.25 kW*	0.37 kW*	2	40050

Clogging indicator					Code
Type	Remark	Code of indicator	Datasheet number	Hydraulic symbol	
Optical - manometer	Only for FA1	DG 200-16	60.20	1	O
Optical - differential pressure indicator	For FA1 or FA1HV	DG 042-05	60.30	2	OD

Pressure hose extension **	
Customized length of the pressure hose (max. 5 m / 16.4 ft). Example of order P4.5 - pressure hose length 4.5 m / 14.8 ft	Px.x

Electric cable extension ***	
Customized length of the electric cable Example of order C8.5 - electric cable length 8.5 m / 27.8 ft equipped with electric plug	Cx.x

* Indications at 50 Hz. At 60 Hz the value increases by approx. 20 %

** As standard, the unit is equipped with the following hoses

FA1 suction hose: DN 19, length 1.8 m / 5.9 ft with suction filter 300 μm , \varnothing approx. 49 mm / 1.9 inch (installed at the free end of the hose)

FA1 pressure hose: DN 19, length 2.0 m / 6.6 ft with aluminum lance length 25 cm (installed at the free end of the hose)

FA1HV suction hose: DN 32, length 1.5 m / 4.9 ft with aluminum lance length 25 cm / 9.8 inch (installed at the free end of the hose)

FA1HV pressure hose: DN 25, length 2.0 m / 6.6 ft with aluminum lance length 25 cm / 9.8 inch (installed at the free end of the hose)

*** As standard, the unit is equipped with an electric cable, length 2.5 m / 8.2 ft.

Accessories:

- › Suction strainer set FA 016.1775 for tank openings on request, in case the existing suction strainer cannot be used.
- › Mounting set FA 008.1700 for tank openings with ventilating filter, e.g. as service connection on request.

Order example:

FA1 008V005/23050-OP3.5 - oil service unit, standard version, flow 8 l/min / 2.11 gpm, filter element 5 μm , motor 1~230 VAC, optical manometer, standard suction hose, customized pressure hose, length 3.5 m / 11.5 ft, standard electric cable.

Dimensions

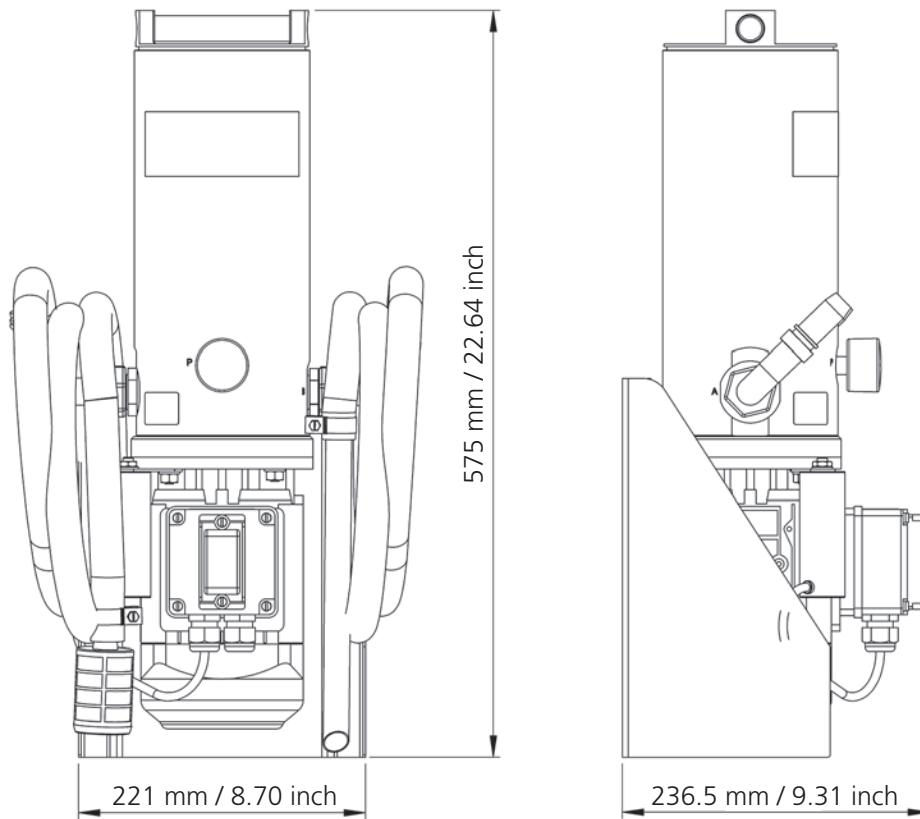

Hydraulic symbols

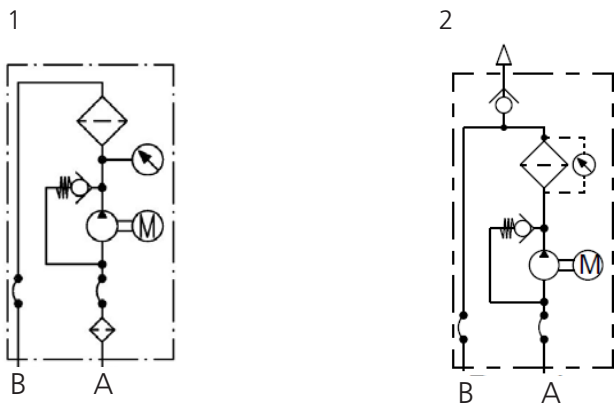

Electric plug*

1: Type E/F (CEE7/7 Unischuko)

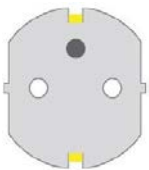

2: With phase crossover, 5-pins (3P+N+PE), IEC 60309

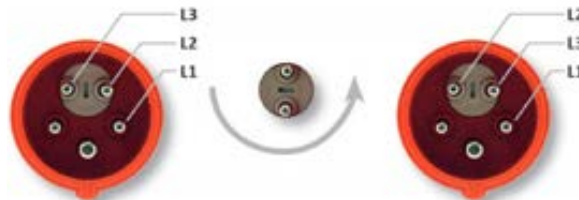

* other plugs on request

FA 016 · FAPC 016

Oil Service Unit FAPC 016



Integrated OPCOM Particle Monitor



Rear view Oil Service Unit FAPC 016

- › Easy filling and cleaning
- › Compact design, comfortable handling
- › High filtration efficiency
- › Option: with oil cleanliness monitor and data storage

Description
FA 016

With the FA 016, hydraulic and lubricating systems can be easily filled or cleaned with off-line filtration.

Compact design and comfortable handling

The compact design allows easy access to the oil tank. The FA 016 comes ready to connect with hose packages. The ultra-fine elements can quickly be changed without special auxiliary tools. The suction hose and the pressure hose can be wound around the hose fixtures. Residual oil from the hoses is collected in the oil pan.

Protection of components through ultra-fine filtration

The EXAPOR®MAX 2 ultra-fine elements are the heart of the ARGO-HYTOS Cleanline portable systems. High separation efficiencies guarantee excellent cleanliness levels and thereby highest protection of components. The high dirt holding capacity of the EXAPOR®MAX 2 ultra-fine elements allows economic operation of the Cleanline portable.

FA 016 with OPCOM Particle Monitor – FAPC 016
2 in 1: FA 016 with Oil Cleanliness Monitor OPCOM

The FA 016 can be equipped with an oil cleanliness monitor. The ARGO-HYTOS OPCOM Particle Monitor permanently monitors the current cleanliness class during the cleaning or filling process.

When monitoring the cleanliness class, a ball valve is used to select "behind filter" (e.g. when filling systems) or "before filter" (e.g. when cleaning filled oil). At the display of the OPCOM Particle Monitor, the ordinal numbers of the particle sizes 4, 6, 14 and 21 µm are shown according to ISO 4406:1999.

The FAPC 016 can store up to 3000 data sets. A PC-software for data recording and representation of the measured values can be downloaded for free at www.argo-hytos.com. The data can be transmitted to a computer via an RS232 interface so that the development can be visualized and followed graphically or in table form.

Easy Transport

For easy transportation of the FA 016 and FAPC 016, an optional trolley can be hooked onto the standing unit. Trouble-free transport over long distances is also possible.

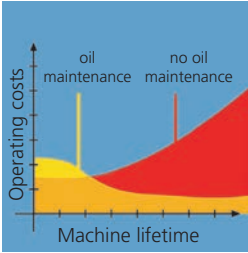

Economical

The FA 016 · FAPC 016 Oil Service Unit offers protection that can extend the lifetime of machinery. This protection gives a direct return on investment through extended service intervals and increased machine availability.



Portable in any position

Thanks to the compact design, the FA 016 · FAPC 016 can be easily carried and also be used in inaccessible areas of hydraulic systems. Hoses and electric cables can be fixed at the service unit. The Cleanline portable can be operated and transported in both upright and horizontal positions.



User-friendly filter element change

The filter element can be removed from the housing together with the cover. The dirt retention valve ensures that solid particle sediment is completely removed with the filter element.



Quality in detail

The EXAPOR®MAX 2 ultra-fine element is the heart of the FA 016 · FAPC 016. A high separation efficiency and dirt holding capacity guarantee maximum cleanliness levels and service intervals in line with practical needs.



Controlled cleaning with Oil Cleanliness Monitor OPCOM

The FA 016 · FAPC 016 can optionally be equipped with the ARGO-HYTOS Oil Cleanliness Monitor OPCOM which allows to monitor the oil cleanliness during the cleaning or filling process. The current cleanliness classes are indicated on the display or can be queried via the provided RS232-interface.

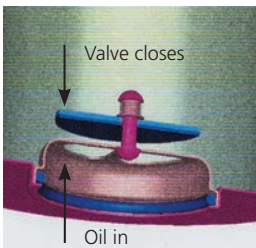

Maintenance-free filter housing thanks to a unique filter element technique

Fluid flows through the element from the inside to the outside. The built-in dirt retention valve closes automatically when the element is removed, ensuring that all dirt is removed from the housing together with the element.

Characteristics

Hydraulic connection

Hoses:

Suction hose NG 20, length 1.8 m / 5.9 ft, with suction strainer 300 µm, Ø approx. 49 mm / 1.9 inch pressure hose NG 20, length 2 m / 6.6 ft, pressure or supply lance Ø approx. 20 mm / 0.8 inch (extensions on request)

Electrical connection / electric motor

Electric motor, air cooled fan type

Cable: length 2.5 m / 8.2 ft
 Electro motor types: 1~ 110 V / 60 Hz
 1~ 230 V / 50 or 60 Hz
 Protection type: IP 55

Tank volume

Approx. 2.4 l / 0.6 gal

Pump design

Internal gear pump

Operating and transport position

Upright or horizontal

Hydraulic fluids

Mineral oil and biodegradable fluids (HEES and HETG, see info service sheet 00.20). Other fluids on request.

Temperature range of fluids

0 °C ... +60 °C / +32 °F ... +140 °F

Ambient temperature range

0 °C ... +50 °C / +32 °F ... +122 °F

Accessories

Water-absorbing filter elements EXAPOR®AQUA. These can be used for short-term water absorption in all standard units (on request).

Trolley

Easy transport over long distances.

Viscosity range

Type	Continuous operation min.	Continuous operation max.	Short-term operation max.
FA 016-11100	15 mm ² /s 70 SUS	250 mm ² /s 1160 SUS	400 mm ² /s 1860 SUS
FA 016-11110	15 mm ² /s 70 SUS	250 mm ² /s 1160 SUS	400 mm ² /s 1860 SUS
FA 016-11300	15 mm ² /s 70 SUS	250 mm ² /s 1160 SUS	400 mm ² /s 1860 SUS
FA 016-11600	15 mm ² /s 70 SUS	250 mm ² /s 1160 SUS	400 mm ² /s 1860 SUS
FAPC 016-12105	15 mm ² /s 70 SUS	150 mm ² /s 695 SUS	150 mm ² /s* 695 SUS*
FAPC 016-12175	15 mm ² /s 70 SUS	150 mm ² /s 695 SUS	150 mm ² /s* 695 SUS*

* An exact measurement of the oil cleanliness class is only possible within a viscosity range from 15 mm²/s / 70 SUS to 150 mm²/s / 695 SUS.

Dimensions

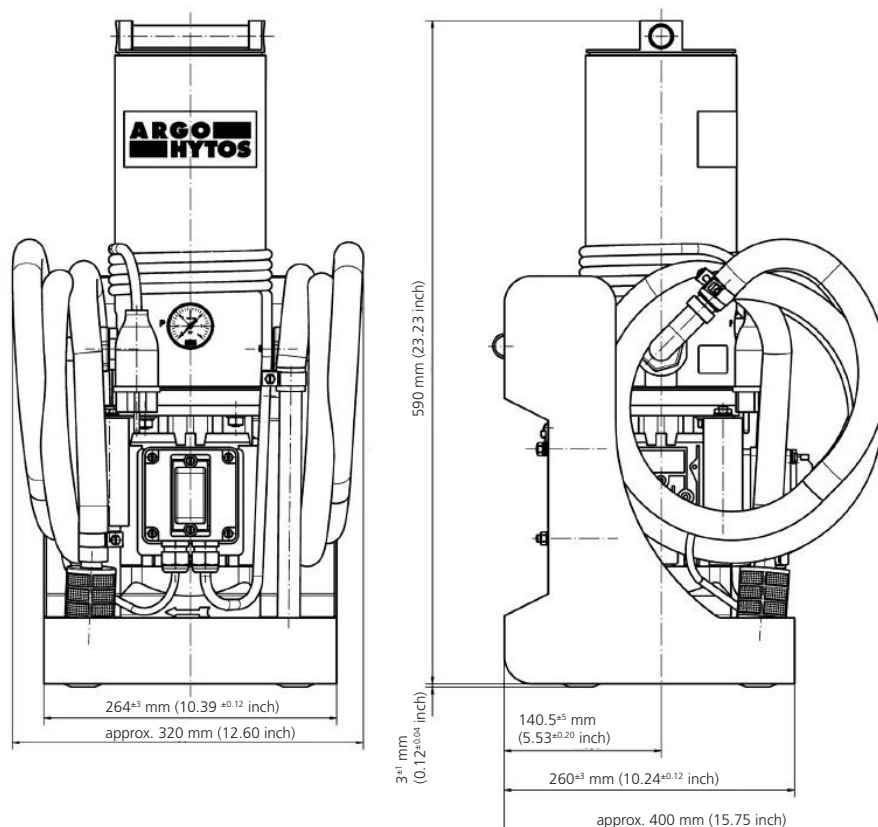

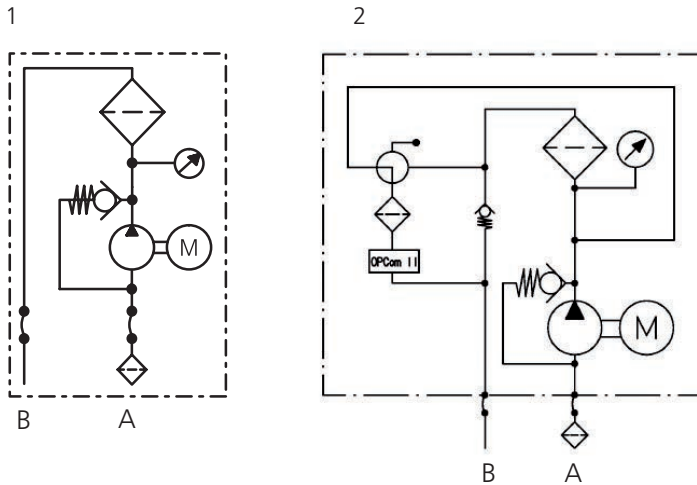

Description

Cleaning speed

The cleaning speed depends on the efficiency of the filter elements ($\beta_{x(c)}$), the nominal volume flow (Q_{nominal}) and the oil volume (V_{actual}).

In graph D1-D2, the cleaning time is shown in relation to the filter fineness (indication of cleanliness classes according to ISO 4406:1999). The values are recorded by laboratory methods and may be influenced by environmental conditions (such as continuous additional introduction of dirt on running systems, high water content, etc.).

All characteristic curves (see graphs D1-D2) relate to a **reference oil volume of 180 l / 47.5 gal** and a **nominal volume flow of 15 l/min / 4 gpm**.

The following formula should be used to convert to the actual oil volume:

$$t_{\text{actual}} = \frac{V_{\text{actual}} \cdot \Delta t}{12 \cdot Q_{\text{nominal}}}$$

- t_{actual} = actual cleaning speed
- Δt = cleaning speed for oil volume of 180 l / 47.5 gal
- V_{actual} = volume of oil to be cleaned
- Q_{nominal} = nominal volume flow, see selection chart

For monitoring purposes we recommend the OPCOM from ARGO-HYTOS, integrated in the version FAPC 016 or the OPCCount Particle Counter.

Determining the cleaning time

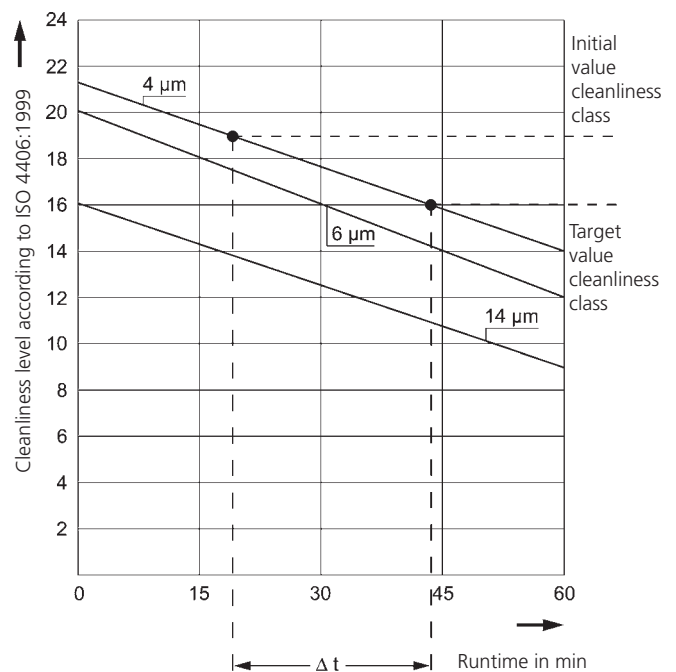

- › Determine the initial cleanliness class and enter it on the graph, e. g. 19/17/14 according to ISO 4406:1999
- › Enter the target cleanliness class on the graph, e.g. 16/14/11 according to ISO 4406:1999
- › Determine Δt , in this case $\Delta t = 25$ min
- › Insert the value in the formula, where $V_{\text{actual}} = 350$ l / 92.5 gal and $Q_{\text{nominal}} = 16$ l/min / 4.2 gpm

$$t_{\text{actual}} = \frac{V_{\text{actual}} \cdot \Delta t}{12 \cdot Q_{\text{nominal}}}$$

$$= \frac{350 (92.5) \cdot 25}{12 \cdot 16 (4.2)} \approx 46 \text{ min}$$

Curves for the cleaning time as a function of the filter fineness

FA 016 with 3EN2 and 5EN2 EXAPOR®MAX2 filter element

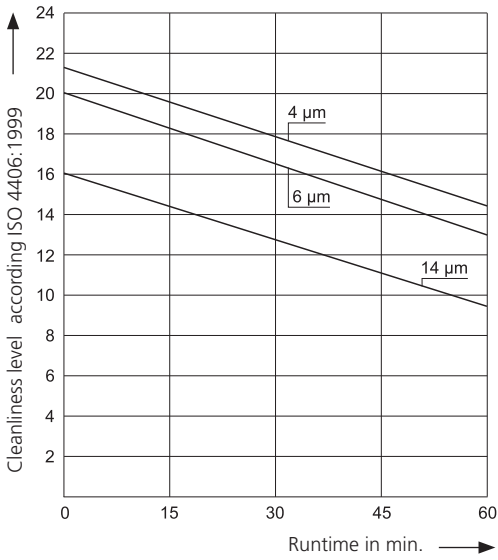

FA 016 with 10EX2 EXAPOR®MAX2 filter element

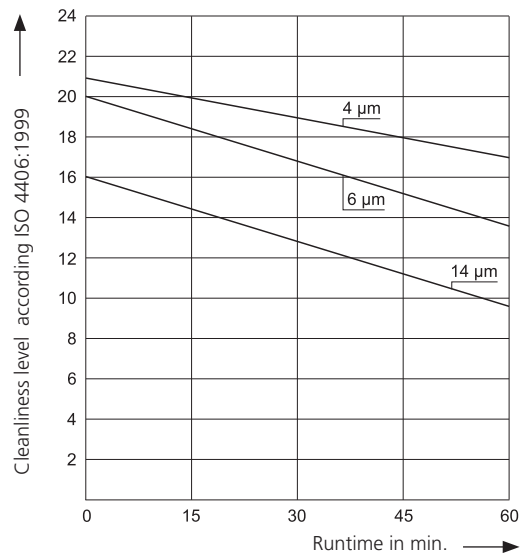

Filter fineness curves in Selection Chart

Dx Filtration ratio β as a function of particle size x obtained by the Multi-Pass Test according to ISO 16889

The abbreviations represent the following β -values resp. finenesses:

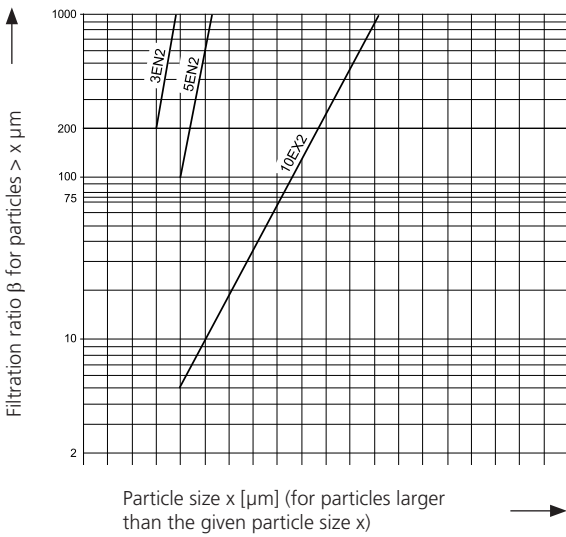

With EXAPOR®MAX2 elements:
 3EN2 = $\bar{\beta}_{3(c)} = 200$ EXAPOR®MAX 2
 5EN2 = $\bar{\beta}_{5(c)} = 200$ EXAPOR®MAX 2
 10EX2 = $\bar{\beta}_{10(c)} = 200$ EXAPOR®MAX 2

Selection Chart

	Order No.	Order No.	Order No.	Order No.	Order No.	Order No.
	FA 016-11100	FA 016-11300	FA 016-11600	FA 016-11110	FAPC 016-12105	FAPC 016-12175
Nominal flow rate	16 l/min* 4.2 gpm*	16 l/min* 4.2 gpm*	16 l/min* 4.2 gpm*	19 l/min* 5.0 gpm*	16 l/min* 4.2 gpm*	16 l/min* 4.2 gpm*
Filter fineness see Diagram Dx	3EN2	5EN2	10EX2	3EN2	3EN2	3EN2
Dirt capacity Mi at Q	280 g	270 g	210 g	280 g	280 g	280 g
E-Motor operating voltage	1 ~ 230 V	1 ~ 230 V	1 ~ 230 V	1 ~ 110 V	1 ~ 230 V	1 ~ 110 V
E-Motor operating frequency	50/60 Hz	50/60 Hz	50/60 Hz	50/60 Hz	50/60 Hz	50/60 Hz
E-Motor power	0.45 kW*	0.45 kW*	0.45 kW*	0.45 kW*	0.45 kW*	0.45 kW*
Length suction hose	1.8 m / 5.9 ft	1.8 m / 5.9 ft	1.8 m / 5.9 ft	1.8 m / 5.9 ft	1.8 m / 5.9 ft	1.8 m / 5.9 ft
Length pressure hose	2 m / 6.6 ft	2 m / 6.6 ft	2 m / 6.6 ft	2 m / 6.6 ft	2 m / 6.6 ft	2 m / 6.6 ft
Viscosity max.	400 mm ² /s 1860 SUS	400 mm ² /s 1860 SUS	400 mm ² /s 1860 SUS	400 mm ² /s 1860 SUS	150 mm ² /s 695 SUS	150 mm ² /s 695 SUS
Suction height max.	1.5 m / 4.9 ft	1.5 m / 4.9 ft	1.5 m / 4.9 ft	1.5 m / 4.9 ft	1.5 m / 4.9 ft	1.5 m / 4.9 ft
Operating pressure PRV max.	4 bar / 58 psi	4 bar / 58 psi	4 bar / 58 psi	4 bar / 58 psi	4 bar / 58 psi	4 bar / 58 psi
Symbol	1	1	1	1	2	2
Replacement element Order No.	V7.1220-113	V7.1220-13	V7.1220-06	V7.1220-113	V7.1220-113	V7.1220-113
Weight	18,9 kg 41.7 lbs	18,9 kg 41.7 lbs	18,9 kg 41.7 lbs	18,9 kg 41.7 lbs	24 kg 52.9 lbs	24 kg 52.9 lbs
Clogging indicator	Manometer	Manometer	Manometer	Manometer	Manometer	Manometer
Particle monitor	-	-	-	-	OPCom	OPCom

* Indications at 50 Hz. At 60 Hz the value increases by approx. 20 %.

Other versions on request.

Filter elements:

See selection chart.

Water-absorbing filter elements EXAPOR®AQUA - on request.

Coarse screen element S7.1220, 100 µm, cleanable and re-usable - on request.

Accessories:

- › Hose extensions on request.
- › For appropriate clogging indicators, please refer to datasheet 60.20.
- › Trolley for FA 016 and FAPC 016 Order No. FA 016-1760.
- › Suction strainer set FA 016.1775 for tank openings on request, in case the existing suction strainer cannot be used.
- › Mounting set FA 008.1700 for tank openings with ventilating filter, e.g. as service connection on request.

Oil Service Units
UM 045 · UMPC 045

Oil service - simple, quick and compact · with integrated particle monitor



UM 045



UMPC 045

 OPCOM Particle Monitor
 (integrated in UMPC)

- › Easy filling, cleaning and pumping over
- › Unbeatable ergonomics, comfortable handling
- › High filtration efficiency
- › Optionally with integrated particle monitor
- › With integrated humidity sensor
- › With automatic switch-off function

Description
Oil service units

Easy, compact and ergonomic

With the oil service unit UM 045 · UMPC 045, hydraulic or lubrication systems can simply be filled, cleaned or fluid can be transferred without using the filter function. The compact size and ergonomic design allows for easy handling in minimal work spaces.

Protection of components through ultra-fine filtration

The EXAPOR®MAX 2 ultra-fine element is the heart of the ARGO-HYTOS oil service unit. A high separation efficiency guarantees excellent cleanliness levels and thereby maximum protection of components. The high dirt holding capacity of the EXAPOR®MAX 2 ultra-fine elements makes the oil service units an economical choice for our customers.

UM 045

The UM 045 comes ready to connect, equipped with hoses. For easy transport, the electrical cables, as well as the suction and return hose, are fixed with support fixtures onto the carrier device. Additional tools can be stowed in the basket of the carrier device.

UMPC 045

The UMPC may be switched off, based on the cleanliness class. Once the desired value has been reached or fallen below for three consecutive times, the device switches off.

In versions -*5735, a particle monitor and a humidity sensor are integrated. Here, the particle classes as well as %rH and temperature are output.

In versions -*5835, a particle monitor and an oil condition sensor are installed. Here, the particle classes %rH, temperature, permittivity and conductivity are issued.

During measurement, data are stored on the SD card and can be transmitted to a computer.

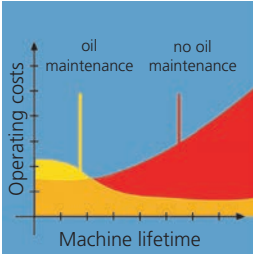

Economical

The UM 045 Oil Service Units offer protection that can extend the lifetime of machinery. This protection gives a direct return on investment through extended service intervals and increased machine availability.



User-friendly filter element change

The filter element can be removed from the housing together with the cover. The dirt retention valve ensures that solid particle sediment is completely removed with the filter element.



Switching functions

The selector valve is used to switch between the basic modes of operation: "filtering" and "pumping over without filtering".



Keeping hoses in place

The retainers attached to the sides of the frame secure the hoses in any transport position.



Compact design

Among the numerous advanced features, listed in the specification of the UM units, compact design was a basic requirement to be met by our team of design engineers. Transporting the UM in horizontal position, e.g. in the cargo area of a service vehicle, is facilitated by the wheels and the curved design of the frame.



Unbeatable ergonomics

Superior technology and excellent design are of no use if the operator can only move the service equipment with great physical effort. Therefore, ergonomics were of primary importance when designing the UM units.

Owing to its optimized weight distribution, the UM can be tilted from the standing position with minimum effort. In the tilted position, the UM can be moved walking upright, removing strain from the back.

Cleaning speed

The cleaning speed depends on the efficiency of the filter elements ($\beta_{x(c)}$), the nominal volume flow (Q_{nominal}) and the oil volume (V_{actual}).

In graph D1-D2, the cleaning time is shown in relation to the filter fineness (indication of cleanliness classes according to ISO 4406:1999). The values are recorded by laboratory methods and may be influenced by environmental conditions (e.g. compared to the laboratory test dust ISO MTD considerably deviating particle constellations, continuous additional introduction of dirt on running systems, high water content, etc.).

All characteristic curves (see graphs D1-D2) relate to a **reference oil volume of 180 l / 47.5 gal** and a **nominal volume flow of 15 l/min / 4 gpm**.

The following formula should be used to convert to the actual oil volume:

$$t_{\text{actual}} = \frac{V_{\text{actual}} \cdot \Delta t}{12 \cdot Q_{\text{nominal}}}$$

- t_{actual} = actual cleaning speed
- Δt = cleaning speed for oil volume of 180 l / 47.5 gal
- V_{actual} = volume of oil to be cleaned
- Q_{nominal} = nominal volume flow, see Selection Chart

For monitoring purposes, we recommend the OPCOM from ARGO-HYTOS, integrated in the version FAPC 016 or the OPCOUNT Particle Counter.

Determining the cleaning time

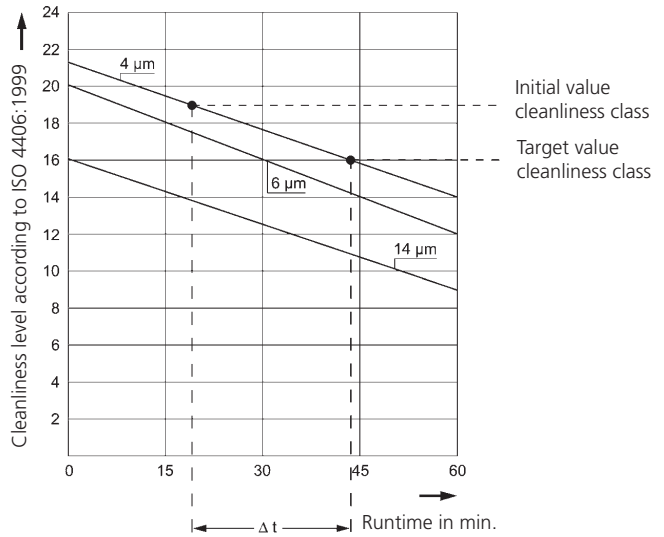

- ▶ Determine the initial cleanliness class and enter it on the graph, e. g. 19/17/14 according to ISO 4406:1999
- ▶ Enter the target cleanliness class on the graph, e.g. 16/14/11 according to ISO 4406:1999
- ▶ Determine Δt , in this case $\Delta t = 25$ min
- ▶ Insert the value in the formula, where $V_{\text{actual}} = 350$ l / 92.5 gal and $Q_{\text{nominal}} = 16$ l/min / 4.2 gpm

$$t_{\text{actual}} = \frac{V_{\text{actual}} \cdot \Delta t}{12 \cdot Q_{\text{nominal}}} = \frac{350 (92.5) \cdot 25}{12 \cdot 16 (4.2)} \approx 46 \text{ min}$$

Curves for the cleaning time as a function of the filter fineness

D1 3EN2 and 5EN2 EXAPOR®MAX 2 filter element
Reference oil volume with $Q_{\text{Off-line filter}} = 15$ l/min / 4 gpm.

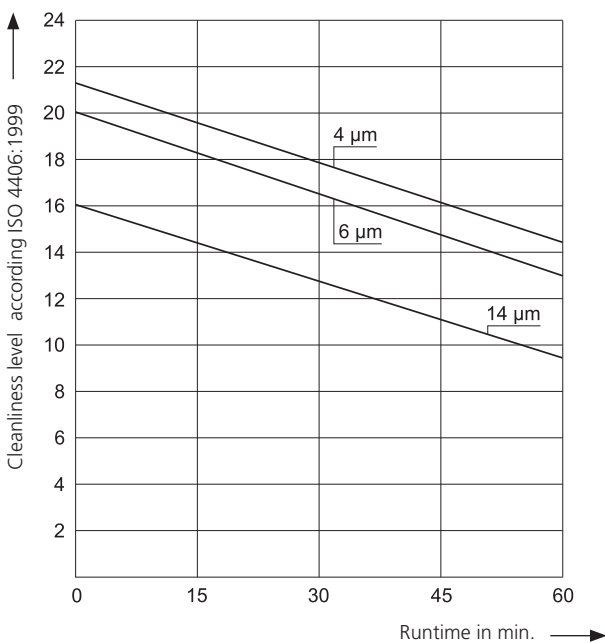

D2 10EX2 EXAPOR®MAX 2 filter element
Reference oil volume with $Q_{\text{Off-line filter}} = 15$ l/min / 4 gpm.

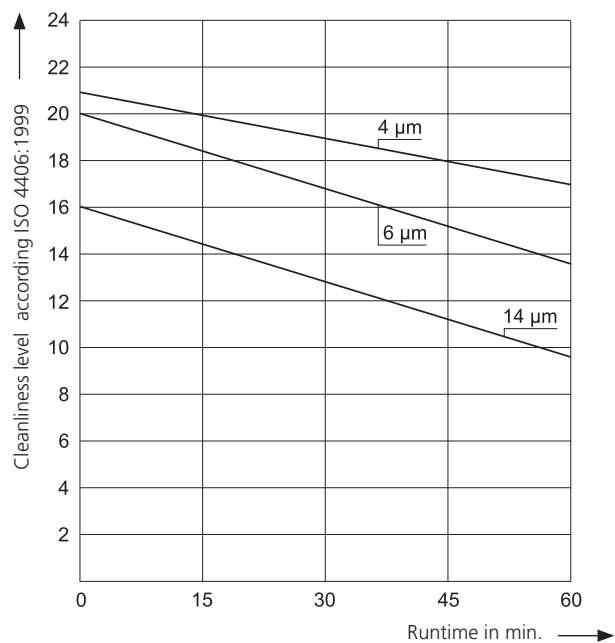

Filter fineness curves in the selection chart

Dx Filtration ratio β as a function of particle size x obtained by the Multi-Pass-Test according to ISO 16889

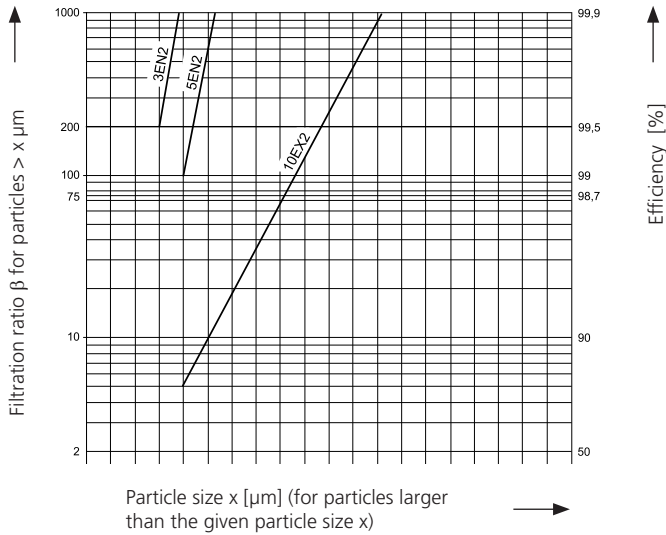

The abbreviations represent the following β -values resp. finenesses:

For EXAPOR[®]MAX2 elements:

3EN2 = $\bar{\beta}_{3(c)} = 200$ EXAPOR[®]MAX2
 5EN2 = $\bar{\beta}_{5(c)} = 200$ EXAPOR[®]MAX2
 10EX2 = $\bar{\beta}_{10(c)} = 200$ EXAPOR[®]MAX2

Characteristics

Hydraulic connection

Hoses:

Suction hose NG 32, length 2.7 m / 8.9 ft,
 with suction strainer 280 μ m,
 pressure hose NG 25, length 2.7 m / 8.9 ft.

Electrical connection / electric motor

Electric motor, air cooled fan type

Cable: length 6 m / 19.7 ft
 Electro motor types: 1 ~ 230 V / 50 Hz
 3 ~ 400 V / 50 Hz
 (3 ~ 460 V / 60 Hz)

Protection type: IP 54
 (see Selection Chart)

Tank volume

Approx. 13 l / 3.4 gal

Pump design

Internal gear pump

Operating and transport position

Operating position: upright
 Transport position: upright or horizontal

Hydraulic fluids

Mineral oil and biodegradable fluids
 (HEES and HETG, see info service sheet 00.20).
 Other fluids on request.

Temperature range of fluids

0 °C ... +65 °C / +32 °F ... +149 °F
 (also see table Viscosity Range)

Ambient temperature range

0 °C ... +50 °C / +32 °F ... +122 °F

Accessories

Water-absorbing filter elements EXAPOR[®]AQUA.
 These can be used for short-term water absorption in all
 standard units (on request).

Viscosity range

Type	Continuous operation min.	Continuous operation max.	Short-term operation max.
UM 045	15 mm ² /s / 70 SUS	600 mm ² /s / 2790 SUS	800 mm ² /s / 3720 SUS
UMPC 045	15 mm ² /s / 70 SUS	250 mm ² /s* / 1160 SUS* 600 mm ² /s* / 2790 SUS*	800 mm ² /s / 3720 SUS

* An exact measurement of the oil cleanliness class is only possible within a viscosity range from 15 mm²/s to 250 mm²/s / 70 SUS to 1160 SUS.

Dimensions

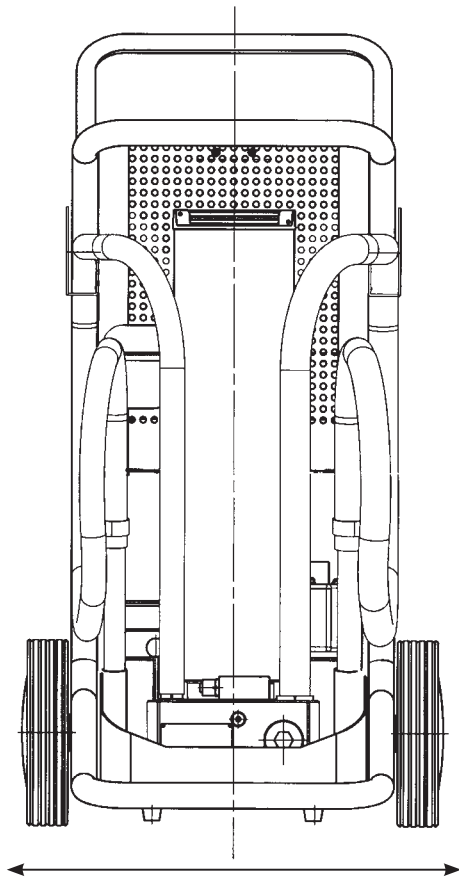

approx. 565 mm / 22.2 inch

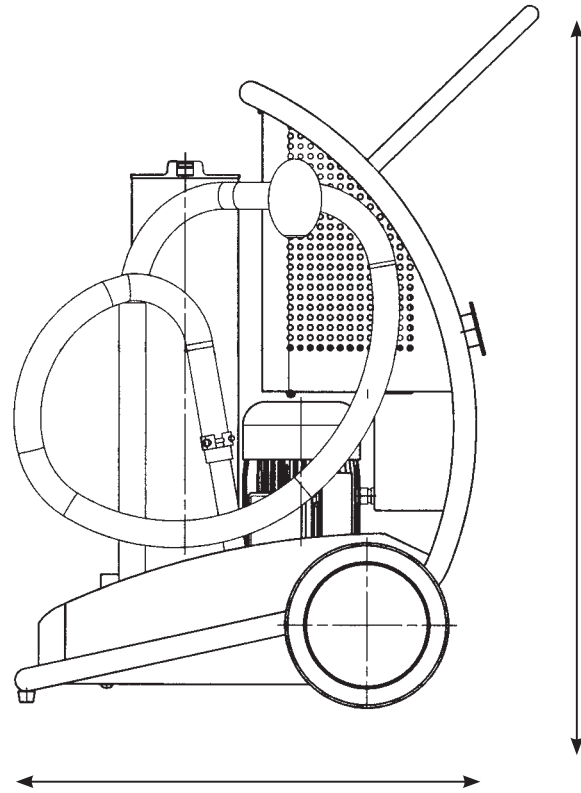

approx. 785 mm / 30.9 inch

approx. 1050 mm / 41.3 inch

Hydraulic symbol - UM 045

1

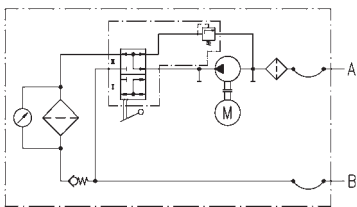

Hydraulic symbol - UMPC 045

2

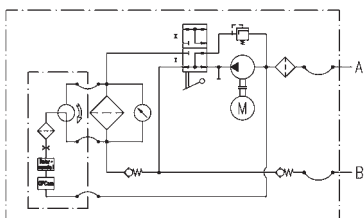

Selection Chart

Order No.	Nominal flow rate	Filter fineness see diagram Dx	Dirt holding capacity	E-Motor operating voltage	E-Motor max. operating frequency	E-Motor power	Length suction hose (lance incl.)	Length pressure hose (lance incl.)	Viscosity	Suction height max.	Hydraulic symbol	Replacement element order no.	Clogging indicator	Weight
Basic model – UM 045														
UM 045-1553	45 l/min** 11.9 gpm**	3EN2	1950 g	1~230 V	50/60Hz	1.1 kW**	2.7 m / 8.9 ft	15 ... 600 mm ² /s 70 ... 2790 SUS	2.0 m 6.6 ft	1	V7.1560-103	optical	76.5 kg 169 lbs	
UM 045-4553	45 l/min** 11.9 gpm**	3EN2	1950 g	3~400V 50Hz 3~460V 60Hz	50/60Hz	1.1 kW**	2.7 m / 8.9 ft	15 ... 600 mm ² /s 70 ... 2790 SUS	2.0 m 6.6 ft	1	V7.1560-103	optical	76.5 kg 169 lbs	
UM 045-1153	45 l/min** 11.9 gpm**	5EN2	1980 g	1~230 V	50/60Hz	1.1 kW**	2.7 m / 8.9 ft	15 ... 600 mm ² /s 70 ... 2790 SUS	2.0 m 6.6 ft	1	V7.1560-03	optical	76.5 kg 169 lbs	
UM 045-4153	45 l/min** 11.9 gpm**	5EN2	1980 g	3~400V 50Hz 3~460V 60Hz	50/60Hz	1.1 kW**	2.7 m / 8.9 ft	15 ... 600 mm ² /s 70 ... 2790 SUS	2.0 m 6.6 ft	1	V7.1560-03	optical	76.5 kg 169 lbs	

UM with integrated Particle Monitor OPCom – UMPC 045														
UMPC 045-15735 ***	45 l/min** 11.9 gpm**	3EN2	1950 g	1~230 V	50/60Hz	1.1 kW**	2.7 m / 8.9 ft	15 ... 600 mm ² /s 70 ... 2790 SUS	2.0 m 6.6 ft	2	V7.1560-103	electr.	97 kg 214 lbs	
UMPC 045-15835 ****	45 l/min** 11.9 gpm**	3EN2	1950 g	1~230 V	50/60Hz	1.1 kW**	2.7 m / 8.9 ft	15 ... 600 mm ² /s 70 ... 2790 SUS	2.0 m 6.6 ft	2	V7.1560-103	electr.	97 kg 214 lbs	
UMPC 045-45735 ***	45 l/min** 11.9 gpm**	3EN2	1950 g	3~400V 50Hz 3~460V 60Hz	50/60Hz	1.1 kW**	2.7 m / 8.9 ft	15 ... 600 mm ² /s 70 ... 2790 SUS	2.0 m 6.6 ft	2	V7.1560-103	electr.	97 kg 214 lbs	
UMPC 045-45835 ****	45 l/min** 11.9 gpm**	3EN2	1950 g	3~400V 50Hz 3~460V 60Hz	50/60Hz	1.1 kW**	2.7 m / 8.9 ft	15 ... 600 mm ² /s 70 ... 2790 SUS	2.0 m 6.6 ft	2	V7.1560-103	electr.	97 kg 214 lbs	

Please request our data sheet no. 100.10 for more detailed information on the OPCom Particle Monitor.

- * The exact determination of the cleanliness class is possible in a viscosity range from 15 mm²/s to 250 mm²/s / 70 SUS to 1160 SUS.
- ** Indications at 50 Hz. At 60 Hz the value increases by 20%.
- *** H₂O + OPCom Particle Monitor, function see description
- **** H₂O+ II + OPCom Particle Monitor, function see description

Other versions on request.

Filter elements:

see Selection Chart.

Water-absorbing filter elements EXAPOR®AQUA on request.

Accessories:

Hose extensions on request.

For appropriate clogging indicators, please refer to datasheet 60.20.

Oil Service Units

UMPCL 045 Lightline

With integrated particle monitor · Optionally with adjustable flow range 20 - 70 l/min / 5.3 - 18.5 gpm



UMPCL 045 Lightline

Description

The UMPCL 045 Lightline is an oil service unit designed for filling and cleaning of hydraulic or lubrication systems and for transferring of fluids. Its compact size and ergonomic design allow easy handling in minimal work spaces.

Protection of systems through ultra-fine filtration

The EXAPOR®MAX 2 ultra-fine filter element is the heart of the UMPCL 045. A high separation efficiency and a large dirt-holding capacity of the filter elements (up to 1980 g) make the UMPCL 045 an economical choice for our customers.

Monitored filtration

The unit is equipped with an oil cleanliness monitor. The OPCOM particle sensor permanently monitors the current cleanliness class during the cleaning or filling process. The data stored in the internal memory can be transmitted to a computer.

Flexible and universal device

Optionally, the unit can be equipped with frequency converter and potentiometer for adjusting the flow rate in the range of 20 - 70 l/min / 5.3 - 18.5 gpm. This additional feature makes the UMPCL 045 even more universal and extends its use to smaller and larger systems. The flow rate can be adapted to the actual need depending on the tank size and / or required speed of the filtration / oil transfer.

Switching valve 1 for changing operating modes

Installed in the pump block - to switch between two modes: "filtering" and "pumping without filtering".

Switching valve 2 for selecting the sampling point

Installed in the front panel - for cleanliness measurement: "behind filter" (e.g. when filling systems) or "before filter" (e.g. for tank cleaning).



Switching valve 1



Switching valve 2



Front panel of the UMPCL 045 Lightline with adjustable flow range

Characteristics

Nominal flow rate

up to 70 l/min / 18.5 gpm - see Ordering Code

Operating pressure

max. 7 bar / 101 psi

Viscosity range*

15 - 1100 mm²/s - continuous operation, flow 20 l/min / 5.3 gpm
 15 - 600 mm²/s - continuous operation, flow 45 l/min / 11.9 gpm
 15 - 400 mm²/s - continuous operation, flow 70 l/min / 18.5 gpm

Temperature range of fluids

0 °C ... +65 °C / +32 °F ... +149 °F
 (also see table Viscosity Range)

Ambient temperature range

0 °C ... +50 °C / +32 °F ... +122 °F

Pump design

Internal gear pump

Electrical motor

3 ~ 400/460 V / 50/60 Hz, 1.1kW
 Protection type: IP 54

Electrical connection**

Cable length 6 m / 19.7 ft with the following electric plug:

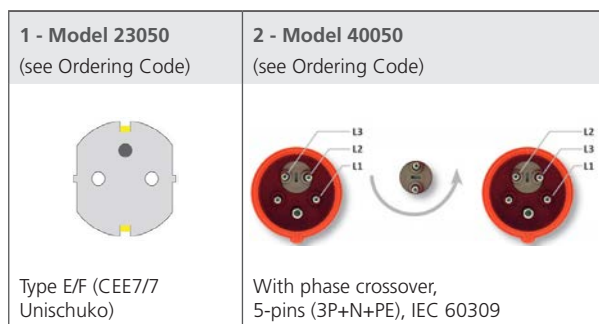

Clogging indicator

optical clogging indication DG 042-04
 (all types) $\Delta p = 3,5 \pm 0.5$ bar

Hydraulic connection

Suction side:

Hose DN 32, length 2.7 m / 8.9 ft with suction pipe

Suction strainer:

Screen element 280 μ m, ordering code S9.0417-13

*Pressure side***:*

Hose DN 25, length 2.7 m / 8.9 ft with pressure pipe

Permitted suction heights

max. 2 m (unfilled)
 max. 6 m (in operating condition)

Hydraulic fluids

Mineral oil and biodegradable fluids
 (HEES and HETG, see info service sheet 00.20).
 Other fluids on request.

Weight

approx. 85 kg / 187.4 lbs

Operating and transport position

Operating position: upright
 Transport position: upright or horizontal

Accessories

Quick connection adapters for suction and pressure hose
 available on request

* An exact measurement of the oil cleanliness class is only possible within
 a viscosity range from 15 mm²/s to 300 mm²/s / 70 SUS to 1160 SUS

** For electric cable extension - see Ordering Code.
 Model 12050 is delivered without electric plug or the plug version should
 be defined individually

*** For pressure hose extension - see Ordering Code

Dimensions

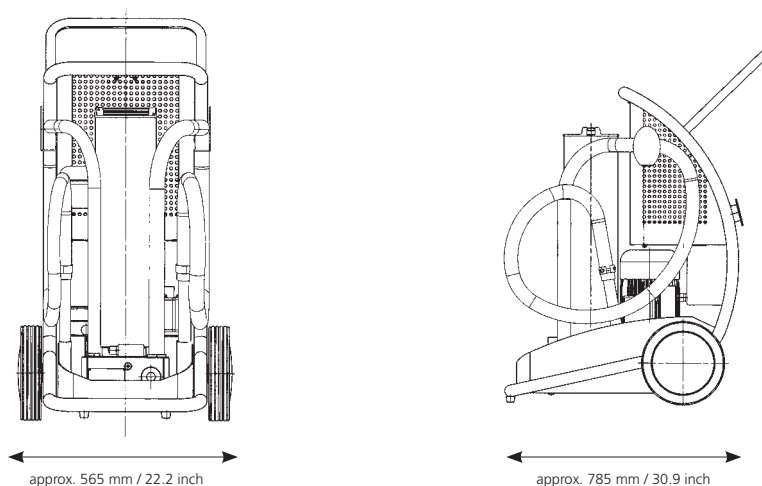

Ordering code

UMPCL 045

Type of unit	Code
Oil service unit with integrated particle monitor	UMPCL 045

Nominal flow	Hydraulic symbol	Code
Fixed nominal flow 45 l/min / 11.9 gpm	1	F
Adjustable flow range 20-70 l/min / 5.3-18.5 gpm	2	A

Filter element					Code
	Fineness ($\beta=200$) Dirt-holding capacity according to ISO 16889 and nominal flow 45 l/min / 11.9 gpm		Water capacity	Spare filter element	
EXAPOR®MAX 2	3 μm	1980 g	-	V7.1560-103	V003
EXAPOR®MAX 2	5 μm	1950 g	-	V7.1560-03	V005
EXAPOR®MAX 2	10 μm	1890 g	-	V7.1560-06	V010
EXAPOR®AQUA	7 μm	590 g	1520 ml	Y7.1560-05	Y007

Input voltage			Code
Connection	Motor power	Plug	
1~230 VAC	1.1 kW	1	23050
3~400 VAC	1.1 kW	2	40050

Pressure hose extension	
Customized length of the pressure hose (max. 5 m / 16.4 ft). Example of order P4.5 - pressure hose length 4.5 m / 14.8 ft	Px.x

Electric cable extension	
Customized length of the electric cable Example of order C8.5 - electric cable length 8.5 m / 27.8 ft equipped with electric plug	Cx.x

Order example:

UMPCL 045A-V003/23050C9.5 - oil service unit with integrated particle monitor, version with adjustable flow range 20 - 70 l/min / 5.3 - 18.5 gpm, filter element 3 μm , input voltage 1~230 VAC, standard suction and pressure hose, and customized length of electric cable 9.5 m / 31 ft

Hydraulic symbol

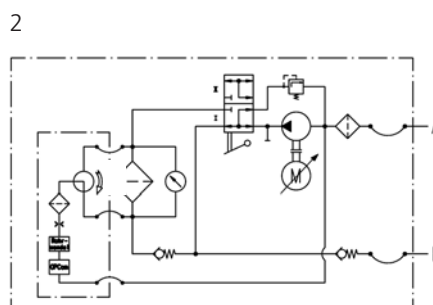
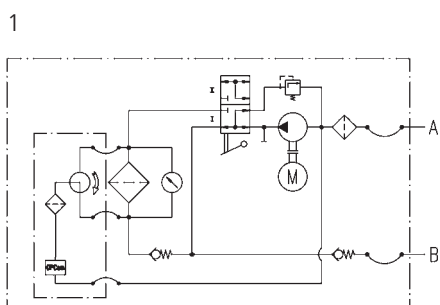

Oil Service Unit for Gear Applications
FA 003-2341

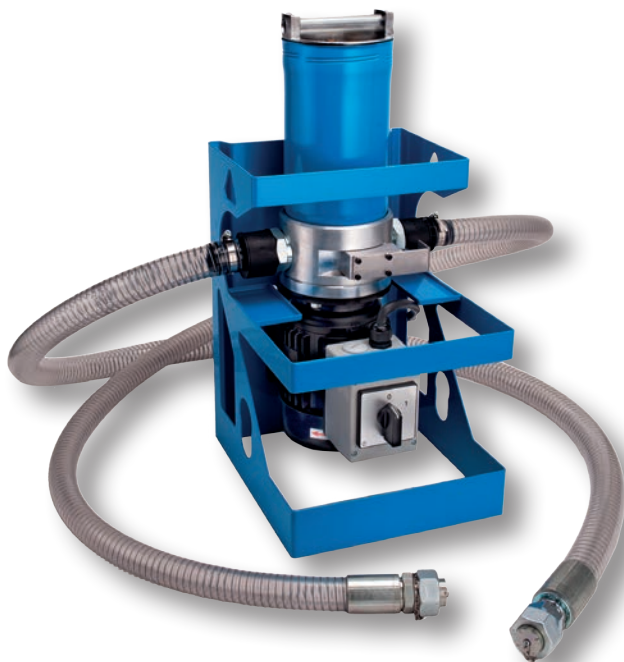
 Easy filling and cleaning · Nominal flow rate up to 3 l/min / 0.8 gpm · Viscosity up to 5.000 mm²/s / 23,000 SUS

Oil Service Unit FA 003-2341

Description
FA 003-2341

The FA 003-2341 Oil Service Unit allows easy filling and cleaning of hydraulic and lubricating systems.

Suitable for up to 5000 mm²/s / 23,000 SUS

The unit is designed to operate with viscosities between 15 and 5,000 mm²/s / 70 and 23,000 SUS. This allows, for example, transmission fluids to be cleaned or filtered while filling, even at low temperatures.

Hydraulic connection

Suction hose DN 32 mm x 1.5 m / 4.9 ft length CEL28 (connection M36 x 2, external thread with sealing cone 24°)
 Pressure hose DN 25 mm x 1.5 m / 4.9 ft length CEL28 (connection M36 x 2, external thread with sealing cone 24°)
 Suction and pressure hoses can be removed or mounted on quickly with special ARGO-HYTOS fast locking couplings.

Hydraulic fluids

Mineral oil and biodegradable fluids (HEES and HETG, see info sheet 00.20).
 Other fluids on request.

Technical data	
Nominal flow rate	3 l/min / 0.8 gpm
Filter fineness	$\beta_{5(\epsilon)} = 200^*$
Dirt-holding capacity	460 g*
Electric drive	3 ~ 400 V, 50 Hz; 0.25 kW
Weight	approx. 22 kg / 48.5 lbs
Temperature range of fluids / viscosity range	0 °C ... +60 °C +32 °F ... +140 °F
Continuous operation min.	15 mm ² /s / 70 SUS
Continuous operation max.	5,000 mm ² /s / 23,000 SUS
Ambient temperature range	0 °C ... +50 °C +32 °F ... +122 °F
Operating pressure	Maximum 6 bar / 87 psi
Clogging indicator	optical

*according to ISO 16889 at 8 l/min and Δp 3 bar / 2.1 gpm and Δp 43.5 psi

Order No.

FA 003-2341

Replacement filter element Order No.

V7.1220-13



Compact and ready to connect

The FA 003-2341 comes ready to connect, with hose packages and filter element.

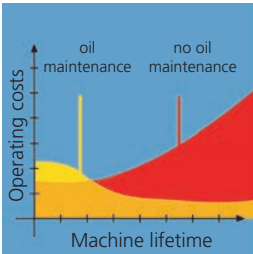

Economical

The FA 003-2341 oil service unit offers protection that can extend the lifetime of machinery. This protection gives a direct return on investment through extended service intervals and increased machine availability.



User-friendly filter element change

The filter element can be removed from the housing together with the cover. The dirt retention valve ensures that solid particle sediment is completely removed with the filter element.

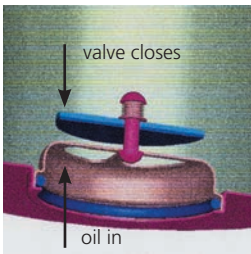

Maintenance-free filter housing thanks to a unique filter element technique

Fluid flows through the element from the inside to the outside. The built-in dirt retention valve closes automatically when the element is removed, ensuring that all dirt is removed from the housing together with the element.

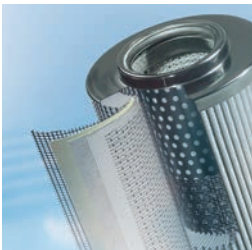

Quality in detail

The EXAPOR®MAX 2 ultra-fine element is the heart of the FA 003. High cleanliness levels protect the system from contamination when filling with oil.



For high oil viscosity

Specifically designed for high viscosity fluids, the FA 003 is highly suited for cleaning and filling oil in gear applications, even at low temperatures- for example: transmission fluid in azimuth gears of wind turbines.

Dimensions

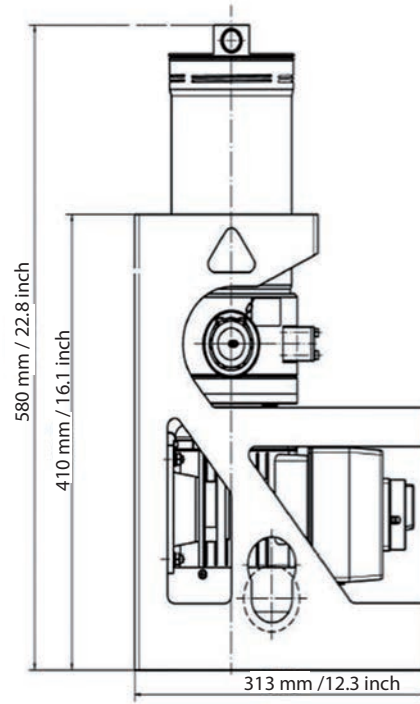
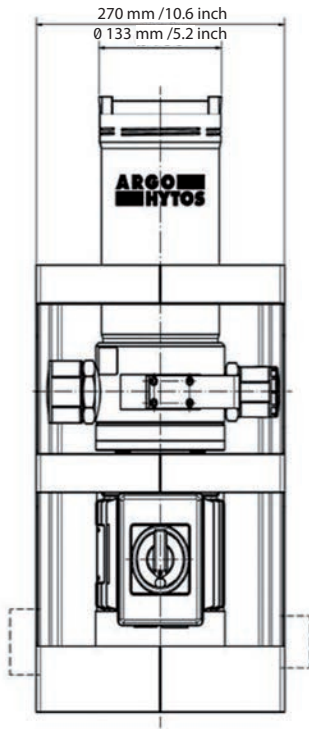

Hydraulic symbol

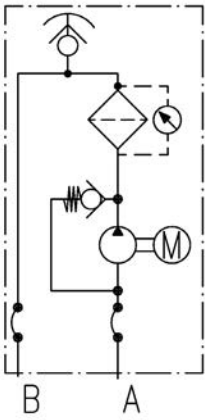

Oil Service Unit
FA 016-1160

Easy filling and cleaning · Nominal flow rate up to 16 l/min / 4.2 gpm · Operating pressure up to 30 bar / 435 psi



Oil Service Unit FA 016-1160

Description
FA 016-1160

With the oil service unit FA 016-1160, hydraulic or lubricating systems can be easily filled or cleaned.

Suitable for up to 30 bar / 435 psi

The unit is designed to operate up to 30 bar / 435 psi filling or system pressure. This allows e.g. filling and filtering of transmission fluids over valve blocks.

Dirt-holding capacity

The dirt-holding capacity values in grams from the ISO MTD test dust are in accordance with the ISO 16889 requirements.

Hydraulic fluids

Mineral oil and biodegradable fluids (HEES and HETG, see info sheet 00.20). Other fluids on request.

Technical data	
Nominal flow rate	16 l/min** / 4.2 gpm**
Filter fineness	$\bar{\beta}_{3(c)} = 200^*$
Dirt-holding capacity	280 g*
Electric drive	1 ~ 230 V / 50 Hz; 1.5 kW, n = 3,000 min ⁻¹
Weight	approx. 30 kg / 66 lbs
Temperature range of fluids / viscosity range	0 °C ... +60 °C +32 °F ... +140 °F
Continuous operation min.	15 mm ² /s / 70 SUS
Continuous operation max.	400 mm ² /s / 1,860 SUS
Ambient temperature range	0 °C ... +50 °C +32 °F ... +122 °F
Operating pressure	Max. 30 bar / 435 psi
Clogging indicator	Optical differential pressure indicator

* with test dust ISO MTD according to ISO 16889

** Indications at 50 Hz. At 60 Hz, the value increases by approx. 20%.

Order No.

FA 016-1160

Replacement filter element Order No.

V7.1220-163



Compact and ready to connect

The FA 016-1160 comes ready to connect, with hose packages and filter element.

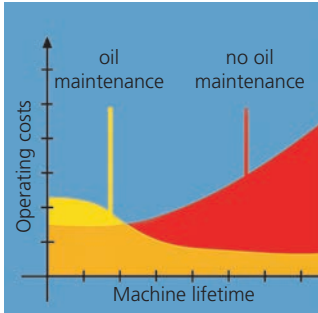

Economical

Das FA 016-1160 oil service unit offers protection that can extend the lifetime of machinery. This protection gives a direct return on investment through extended service intervals and increased machine availability.



User-friendly filter element change

The filter element can be removed from the housing together with the cover. The dirt retention valve ensures that solid particle sediment is completely removed with the filter element.

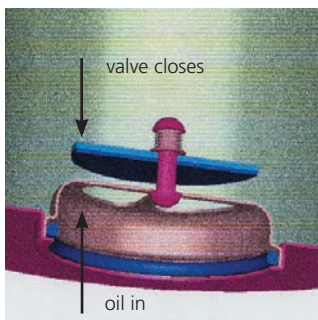

Maintenance-free filter housing thanks to a unique filter element technique

Fluid flows through the element from the inside to the outside. The built-in dirt retention valve closes automatically when the element is removed, ensuring that all dirt is removed from the housing together with the element.

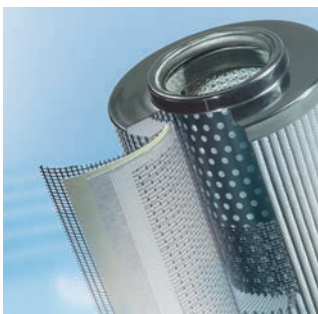

Quality in detail

The EXAPOR®MAX 2 ultra-fine element is the heart of the FA 016-1160. High cleanliness levels protect the system from contamination when filling with oil.

Dimensions

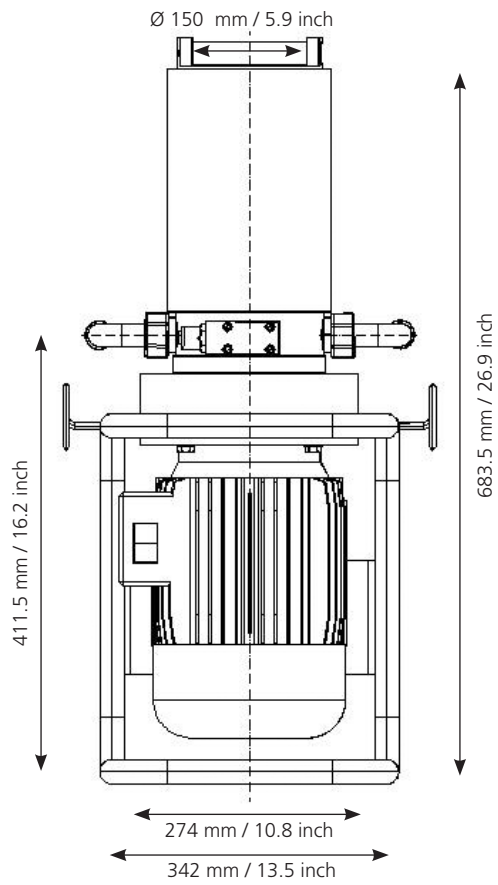

Hydraulic symbol

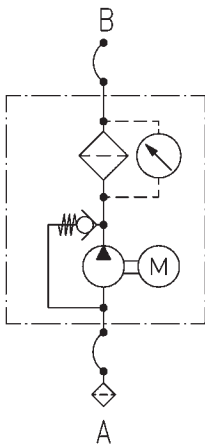

Suction Strainer Set FA 016.1775

FA 014 · FA 016 · FAPC 016 · FNA 008 · FNA 016



FA 016 with screwed-in suction strainer set FA 016.1775

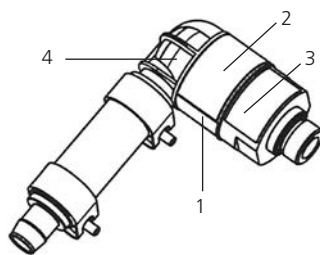
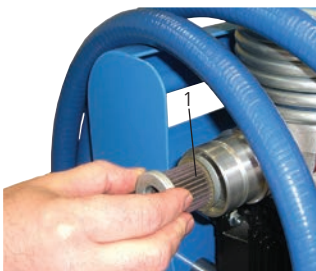

Suction strainer set FA 016.1775

Description

The suction strainer set FA 016.1775 guarantees pump protection, when the existing suction strainer at the suction pipe of the oil service units FA 014, FA 016 and FAPC 016 cannot be used. This is the case, when the oil service units have to be mounted to the hydraulic unit by quick fitting coupling or ball valve, or the opening of the tank is not sufficiently dimensioned. The suction strainer set FA 016.1775 also serves as an alternative for the off-line filter units FNA 008 or FNA 016, if they are mounted to hydraulic units afterwards and installation of a suction strainer within the tank is impossible.

The suction strainer set FA 016.1775 consists of a suction strainer element 200 µm (1), a clip (2), a connection part with O-ring (3) and a connection piece (4).

Installation of the suction strainer set

- › The suction pipe with suction strainer, mounted to the ARGO-HYTOS oil service unit, has to be removed.
- › The suction strainer set FA 016.1775 is directly screwed into the filter housing.
- › A suction pipe with DN 25 is connected (can be locked by hose clip).

The suction strainer set FA 016.1775 is designed in a way, so that the DN 25 hose connection can be rotated by 360° and thus be adapted to the position of the pipe inlet.

Caution:

With application of the FA 016.1775 strainer set in the version of FA 016-1160, an additional male end fitting has to be used!

Maintenance

The suction strainer (1) should be checked once a month with oil service units and every 12 months with off-line filter units.

- › Remove the clip (2) and pull the connection piece (4) from the housing (3).
- › Remove the suction strainer element from the connection piece and clean it with cleaning solvent.
- › Replace the suction strainer element (1), if damaged, by a new one S3.0405-02.
- › Mount cleaned or new suction strainer element (1) S3.0405-02 onto the housing and secure it with the plastic clip (2).

Order-No.:

Suction strainer set complete:	FA 016.1775
Suction strainer element	
filter fineness 200 µm (1):	S3.0405-02

Mounting Set FNA 008.1700

FNA 008 · FNA 016 · (FA 014 · FA 016 · FAPC 016)



Mounting set attached to the tank

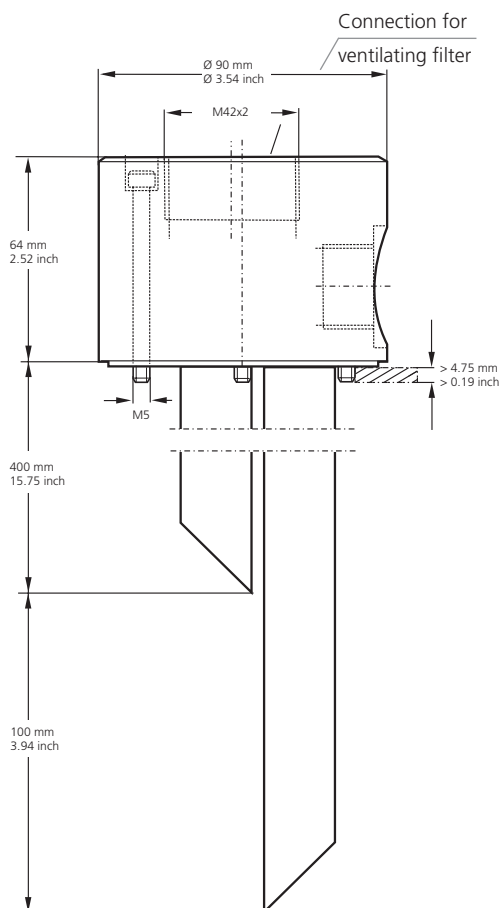

Description

Operating mode and mounting

The mounting set FNA 008.1700 allows easy connection of the supply and discharge pipe to the tank of the ARGO-HYTOS off-line filter units, provided that there is a connection for a ventilating filter at the tank according to the displayed connection scheme (e. g. for ARGO-HYTOS filling and ventilating filter LE.0716 and LE.0817... 0827).

The mounting set can also be used as service connection for ARGO-HYTOS oil service units, e. g. if hydraulic systems require regular oil cleaning. For this purpose, the mounting set is additionally equipped with adequate hose nipples so that the ARGO-HYTOS oil service units can be easily and quickly connected (in this case we recommend to use the suction strainer set FA 016.1775 for pump protection).

Installation of the mounting set

- › Instead of the filling filter, the mounting set FNA 008.1700 is attached to the tank.
- › The off-line filter unit is tubed or piped to the mounting set.
- › The ventilating filter is directly screwed onto the mounting set.

Order No:

Mounting set

FNA 008.1700

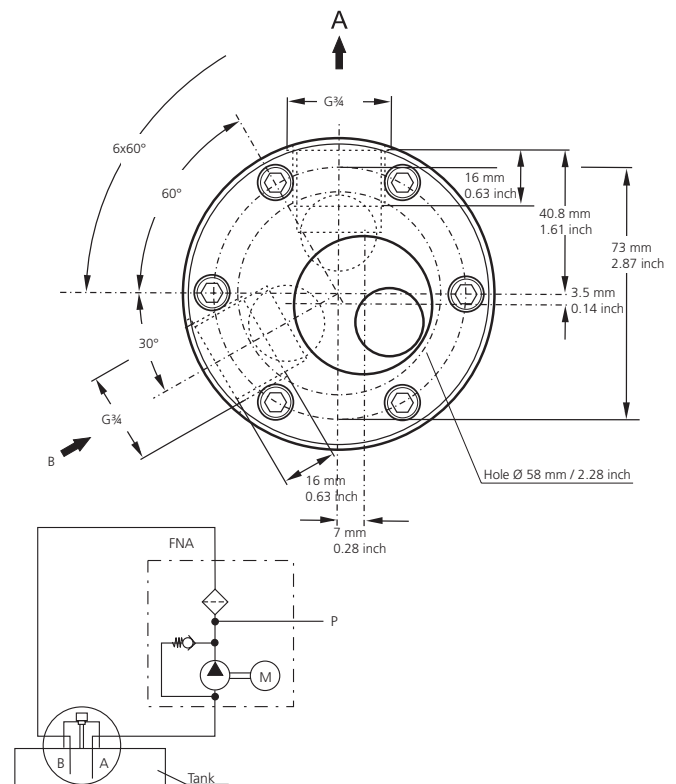

Dewatering Units**OPS 010 · OPS 550**

Dewatering Unit OPS 010



Dewatering Unit OPS 550

Why OPS?

Due to increased demands placed on hydraulic and lubrication systems with respect to lifetime and availability, the importance of the fluid being used, is constantly growing.

Even the smallest amount of free water in oil can cause acidification and thus lead to corrosion of component surfaces.

An increased water content can dramatically alter the characteristics of the oil. The consequences include: reduced load capacity, lower temperature resistance and, ultimately, rapid oil oxidation (aging), which all results in equipment damage and costly repairs.

Some of the causes of water in hydraulic and lubricating oil are: Ambient moisture, splash water and cooler breakage.

With the new OPS mobile dewatering unit, large quantities of free water can be removed efficiently. The oil is heated, if necessary, and channeled into a vacuum chamber.

The water is removed, long before the saturation limit is reached, thanks to the reduced steam pressure.

A fine filter is installed downstream from the drying process to ensure that the oil is dry and filtered when it flows back into the machine or tank.

The water content is constantly monitored with the ARGO-HYTOS LubCos H₂O water sensor. Thus, the user is always up-to-date.

Thanks to the available combinations of the device, the OPS is always perfectly equipped.

Functionality

The unit separates free and dissolved water from hydraulic and lubricating oils. By means of a vacuum pump, low pressure is produced within the reactor and oil is sucked in via the oil inlet. A heater warms up the oil to the adjusted temperature.

Inside the reactor, the water evaporates far below the saturation limit. The steam is cooled down and condensed. The condensed water conglomerates in a collection tray. The dried oil conglomerates within the reactor. Herein, level switches are found for switching on and off the outlet pump. As soon as the filling level has been reached, the outlet pump will operate and deliver the dewatered oil to the oil outlet.

On site, the cooled oil sample can be inspected visually. As long as the cooled oil is clouded, the water content is inadmissible high. If the cooled oil sample appears to be clear, the water content lies within the permitted range. An exact examination of the water content is carried out by an oil sample analysis in the laboratory (e.g. determination of the water using the Karl-Fischer-Method according to DIN 51777).

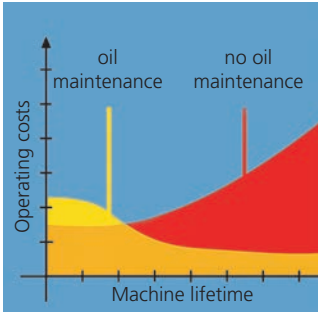

Economical

The OPS 10 · OPS 550 Dewatering Units offer protection that can extend the lifetime of machinery. This protection gives a direct return on investment through extended service intervals and increased machine availability.



Easy handling

The operating panel is clearly and easily arranged. All operating elements and indications can be realized at a glance.



User-friendly filter element change

The filter element can be removed from the housing together with the cover. The dirt retention valve ensures that solid particle sediment is completely removed with the filter element.



Efficient dewatering

The vacuum chamber and tempering of the oil allow dewatering far below the saturation limit.



Monitored dewatering

With the humidity sensor LubCos H₂O, the relative humidity is monitored during the dewatering process.

Diagrams

OPS 010

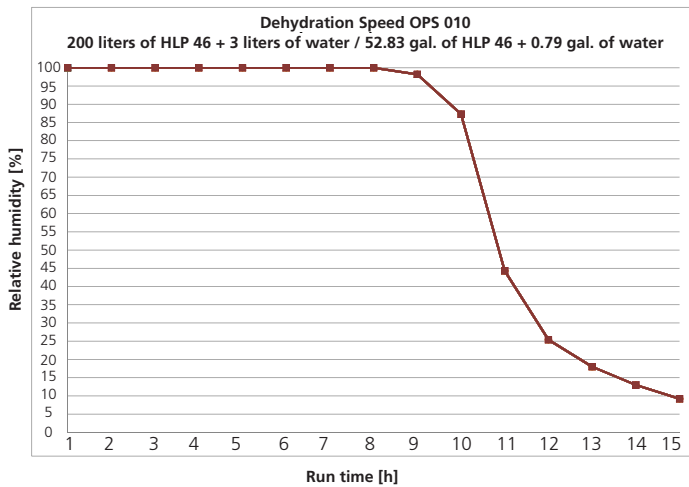

Technical data

	OPS 010
Nominal flow rate	10 l/min / 2.6 gpm
Filter fineness	5 µm
Operating voltage	3 ~ 400 V
Operating frequency	50 / 60 HZ
Nominal current	16 A
Power	max. 7.4 kW
Viscosity min.	10 mm ² /s / 46 SUS
Viscosity max.	700 mm ² /s / 3244 SUS
Dewatering rate	0.9 l/h* / 0.2 gal/h*
Connection A	¾" BSP
Connection B	1" BSP
Replacement filter element	V7.1230-53
Dirt-holding capacity	220 g
Weight	160 kg / 353 lbs (without accessories)
Dimensions (length x width x height)	600 x 565 x 1200 mm / 23.6 x 22.2 x 47.2 inch

* typical dewatering rate with 200 liters / 52.83 gallons of oil at > 10,000 ppm water content

Dimensions

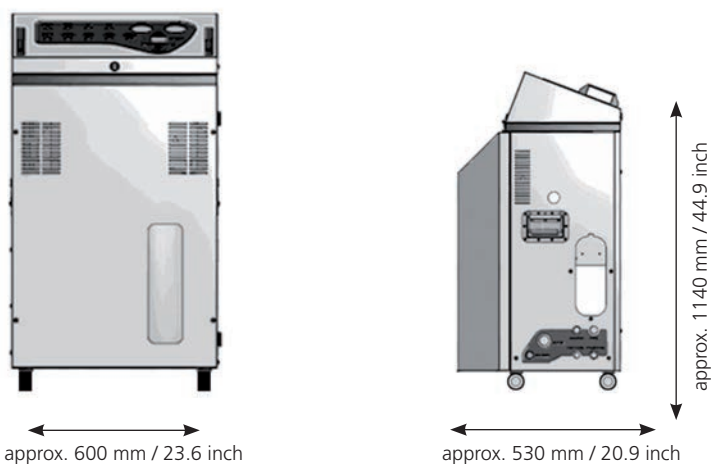

Diagrams

OPS 550

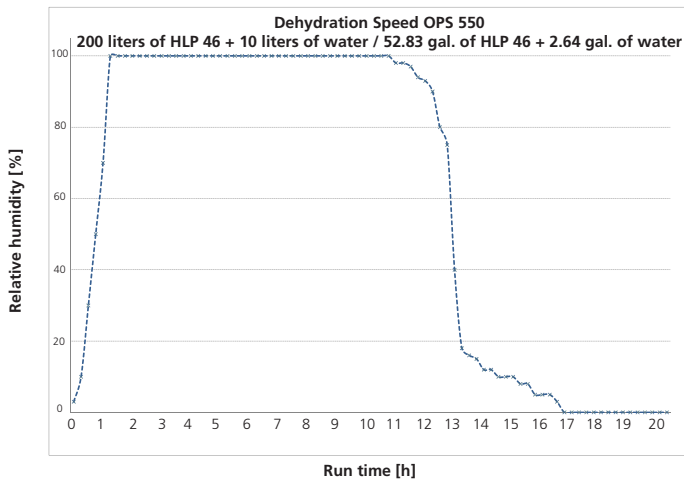

Technical data

	OPS 550
Nominal flow rate	50 l/min / 13.2 gpm
Filter fineness	5 µm
Operating voltage	3 ~ 400 V
Operating frequency	50 / 60 HZ
Nominal current	32 A
Power	max. 13 kW
Viscosity min.	15 mm ² /s / 69 SUS
Viscosity max.	500 mm ² /s / 2317 SUS
Dewatering rate	1.65 l/h* / 0.4 gal/h*
Connection A	1¼" BSP
Connection B	1" BSP
Replacement filter element	V7.1560-03
Dirt-holding capacity	600 g
Weight	730 kg / 1609 lbs (without accessories)
Dimensions (length x width x height)	1500 x 1000 x 1780 mm / 59.1 x 39.4 x 70.1 inch

* typical dewatering rate with 200 liters / 52.83 gallons of oil at > 10,000 ppm water content

Dimensions

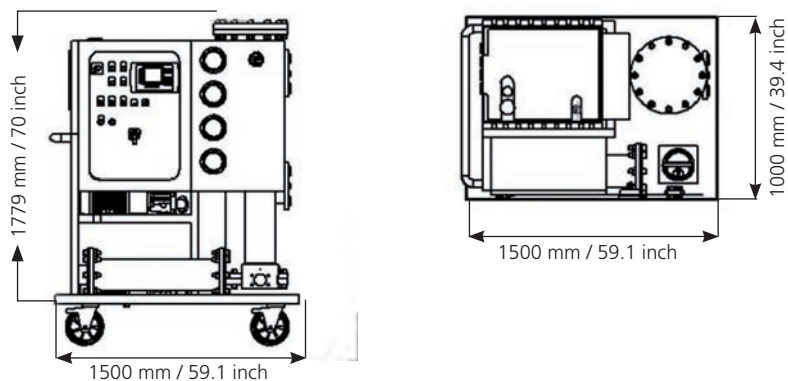

Filter Elements

EXAPOR®AQUA

For water separation



EXAPOR®AQUA Filter Elements



Oil Service Unit FAPC 016



Off-line Filter Unit FNA 008/016

Description

Application

Quick and efficient dewatering of hydraulic and lubrication oils.

Water in hydraulic and lubrication oils may have the following causes:

- › Cooler breakage
- › Environment humidity
- › Spray-water
- › Fresh oil

Already small quantities of free water in oil can lead to acidification. Corrosion of surfaces at components can be the result. Due to free water, the oil characteristics change, e.g. decreased load-carrying capacity, reduced temperature resistance. In order to avoid economic damage, the oil must be protected against free water or existing water must be withdrawn as fast as possible.

Large water quantities can be withdrawn by oil change, flushing of the system or with dewatering units. At systems with hygroscopic oils (materials that absorb water are described as hygroscopic) or with permanent water entry through seals (e.g. hydraulic excavator used in water constructions), ARGO-HYTOS off-line filters and filter units with EXAPOR®AQUA filter elements can be permanently installed in the system, in order to withdraw water. To withdraw remaining water quantities, e.g. after new filling, the ARGO-HYTOS EXAPOR®AQUA elements in portable off-line filter units also can be used during operation of the system.

EXAPOR®AQUA filter elements are applicable in different ARGO-HYTOS filter units. Depending on the operating situation, the water absorption amounts to approx. 350 ml / element. The combination of water absorbing filter layers with micro-filter material also allows the use of EXAPOR®AQUA in hydraulic and lubrication systems with high requirements to the oil cleanliness.

The efficiency of the EXAPOR®AQUA filter elements can be analyzed on-site. As long as a turbidity is visible in the cooled down oil, the water content is, in most cases, unacceptably high. If the cooled down oil sample appears clear, the water content usually lies in the permissible range. An exact measurement of the water content is made by an oil sample analysis in the laboratory (e.g. water content regulation with the Karl Fischer method in accordance to DIN 51777).

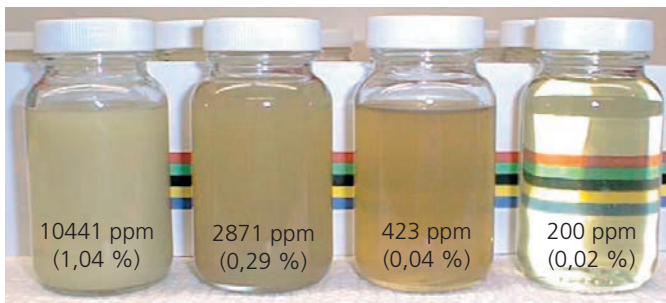

Oil samples with varying water content

Selection chart

EXAPOR®AQUA Filter element designation	Water capacity per element at $v = 30 \text{ mm}^2/\text{s}$ / 140 SUS		Filter fineness	Dirt-holding capacity (values in g test dust ISO MTD according to ISO 16889)			Applicable in ARGO-HYTOS filter units
	ml	gal			l/min	gpm	
Y7.1560-05	1520	0.40	7 μm	590 g at	45	11.9	FNA 045, UM 045, UMPC 045
Y7.1220-113	340	0.09	3 μm	64 g at	60	15.9	FA 008, FA 016, FAPC 016, FNA 008, FNA 016 (with filter element size V7.1220)
Y7.1220-05	370	0.10	7 μm	44 g at	60	15.9	FA 008, FA 016, FAPC 016, FNA 008, FNA 016 (with filter element size V7.1220)
Y7.1230-153	520	0.14	3 μm	130 g at	60	15.9	FN 060, FNS 060, FNA 040

International

ARGO-HYTOS worldwide

Benelux	ARGO-HYTOS B.V.	info.benelux@argo-hytos.com
Brazil	ARGO-HYTOS AT Fluid Power Systems LTDA.	info.br@argo-hytos.com
China	ARGO-HYTOS Fluid Power Systems	info.cn@argo-hytos.com
Czech Republic	ARGO-HYTOS s.r.o ARGO-HYTOS Protech s.r.o	info.cz@argo-hytos.com info.protech@argo-hytos.com
France	ARGO-HYTOS SARL	info.fr@argo-hytos.com
Germany	ARGO-HYTOS GMBH	info.de@argo-hytos.com
Great Britain	ARGO-HYTOS Ltd.	info.uk@argo-hytos.com
Hong Kong	ARGO-HYTOS Hong Kong Ltd.	info.hk@argo-hytos.com
India	ARGO-HYTOS PVT. LTD.	info.in@argo-hytos.com
Italy	ARGO-HYTOS S.r.l.	info.it@argo-hytos.com
Poland	ARGO-HYTOS Polska spz o.o.	info.pl@argo-hytos.com
Russia	ARGO-HYTOS LLC	info.ru@argo-hytos.com
Sweden	ARGO-HYTOS Nordic AB	info.se@argo-hytos.com
Turkey	ARGO-HYTOS Hid Ekip. San. ve Tic Ltd. Sti.	info.tr@argo-hytos.com
USA	ARGO-HYTOS Inc.	info.us@argo-hytos.com

