

SIEMENS

Ingenuity for life

Project6 > Control device_1 [SIMOCODE pro V] > Traces > Trace

Status: Recording completed



Take a step into the future
with SIMOCODE pro

The motor management system for safety,
transparency and efficiency. Connected to the Cloud.

[siemens.com/simocode](https://www.siemens.com/simocode)



SIMOCODE pro. A long-established synonym for motor management.

People today use the word SIMOCODE to mean “motor management and control devices” because, among specialists, SIMOCODE has long since become a generic term for this technology. Because SIMOCODE pro is uncomplicated and easy to use. Because you can rely on SIMOCODE pro over many, many years. And because SIMOCODE pro always leads the field from a technological viewpoint.

As it is doing now with its interface to the Cloud.

Flexible, modular, integrated.

The way modern motor management should be.

For 30 years now, SIMOCODE pro has been controlling and monitoring low-voltage, constant-speed motors all over the world. Wherever motors keep things running in the process industry, SIMOCODE is there. Many thousands of times over. Now even more powerful thanks to connection to the Cloud.

The highlights of SIMOCODE pro

- Extensive protection, monitoring and control functions, independent of the automation system
- Detailed operational, service and diagnostics data – at any time or place
- Safe shutdown of motors
- Scalable, flexible solutions for all plant configurations
- Versatile, open communication via various bus systems and protocols
- Integration in process control systems such as SIMATIC PCS 7

SIMOCODE pro offers multifunctional, solid-state full motor protection. The motor management system monitors, protects and controls constant-speed motors and enables the implementation of predictive maintenance. It does not wait for a problem to occur before shutting down the motor, but establishes a level of transparency in advance. This avoids plant standstills and improves economic efficiency.

SIMOCODE pro delivers detailed operating, service and diagnostic data from across the entire process. The engineering is simple and likewise the integration into process control systems. SIMOCODE pro communicates via PROFIBUS and PROFINET, Modbus, EtherNet/IP and OPC UA. It implements simple and economical motor management.

With both the SIMOCODE pro General Performance and SIMOCODE pro High Performance device classes, we offer scalable, flexible solutions for industrial controls and plant optimization in the context of Industrie 4.0.

SIMOCODE pro. A really strong family.

Two functionally graded device series form the core of the multifunctional SIMOCODE pro motor management system: General Performance and High Performance. The devices in both series incorporate all essential motor protection, monitoring and control functions – including data transparency through the Cloud connection. SIMOCODE pro General Performance is your entry into modern motor management and addresses standard motor applications. SIMOCODE pro High Performance features up to five expansion modules and offers additional measured variables. Find out how you can take advantage of the two SIMOCODE pro device series in all areas of the process industry.



SIMOCODE pro – General Performance: Ideal for the entry level

The smart and compact motor management system for direct-on-line, reversing, and star-delta (wye-delta) starters or for controlling a motor starter protector or soft starter. The basic system includes a current measuring module and the basic unit for overload or thermistor motor protection, for example. Communication with the automation level takes place via PROFIBUS/PROFINET. Optional additions include an operator panel and an expansion module that allows additional inputs/outputs, ground-fault detection and temperature measurement to be realized.

SIMOCODE pro – High Performance: The fully professional solution for every motor

The SIMOCODE pro High Performance motor management system is variable, intelligent and can be adapted individually to suit every requirement. The basic system includes a module for measuring current (and optionally also voltage), as well as a basic unit, and is suitable for removing pump blockages, for example. Communication with the automation level takes place via PROFIBUS or Modbus RTU, via Ethernet with the PROFINET or EtherNet/IP protocols, and also via OPC UA. The optional expansions available include separate current/voltage measuring modules for dry-running protection, an operator panel with display, a ground-fault module, a temperature module, standard digital modules, fail-safe digital modules and an analog module.

SIMOCODE pro Safety:
Fail-safe expansion modules

Various modules are available for SIMOCODE pro for the extended protection of personnel, machines and the environment. These guarantee the safety-related shutdown of motors and meet all the requirements of the standards.

The advantages:

- Functional switching and fail-safe shutdown without manual wiring or additional effort
- Safety function parameters can be flexibly configured
- Transfer of meaningful diagnostic data to the control system
- Logging of errors for detailed evaluation
- Fail-safe shutdown via PROFIsafe



	PROFINET IO/OPC UA	ETHERNET/IP	PROFIBUS	MODBUS RTU	
High Performance	SIMOCODE pro V PN	SIMOCODE pro V EIP	SIMOCODE pro V PB	SIMOCODE pro V MR	Current/voltage measuring module
					Operator panel with display
					max. 5/7 expansion modules
					Safety
					Extended control functions (e.g. positioner, pole-changing starter)
General Performance	SIMOCODE pro V PN GP		SIMOCODE pro S		Current measuring module
					Operator panel
					1 expansion module
					Basic control functions (e.g. direct-on-line/reversing start)

Remove pump blockages and increase availability.

Say goodbye to blocked pumps with SIMOCODE pro – the modular, compact motor management system that tackles the challenge by automatically reversing the pump. Another benefit: SIMOCODE pro can be retrofitted in existing plants.

Every water utility is familiar with the problems of a blocked pump – and the possible consequences: environmental harm, damage due to flooding, and dangers to health as a result of lifting and cleaning pumps. This is compounded by the financial impact of plant downtimes. SIMOCODE pro monitors the current and active power of the pump motor – and derives the pump status from them. If a defined

threshold value is exceeded, SIMOCODE pro autonomously reverses the rotational direction of the pump in order to dislodge deposits on the impeller blades, for example.

SIMOCODE pro – The advantages at a glance

- Minimized downtimes – with less maintenance work
- Energy and cost savings over the entire plant life cycle
- Simple use
- Scalable solution
- A choice of networked or autonomous configuration



Reliable monitoring. Dry-running protection reconceptualized.

Reliable dry-running protection is a must in many applications in the chemical industry. SIMOCODE pro reliably prevents the dry running of centrifugal pumps in order to preclude hazardous situations – and completely redefines dry-running protection for pumps in hazardous areas with an innovative solution.

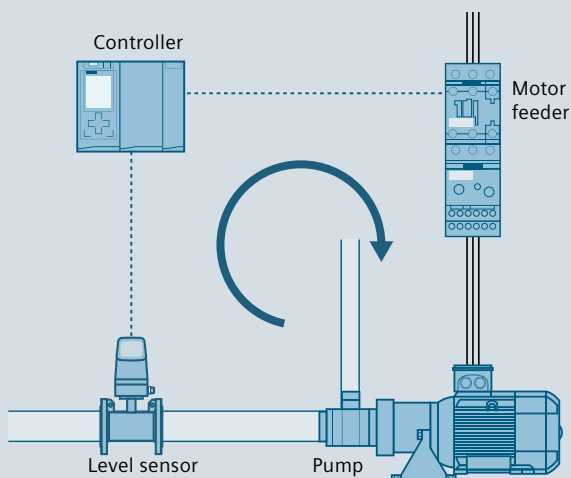

Conventional dry-running monitoring with a sensor

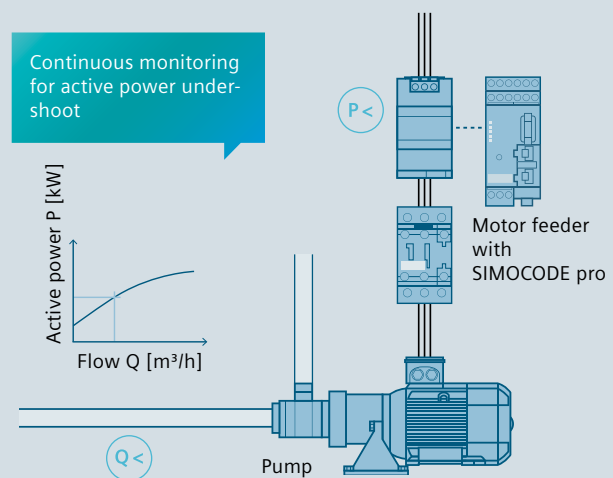

Active power-based dry-running protection

Sensors on centrifugal pumps in hazardous areas are often prone to fault and are thus high-maintenance. The solution: Using active power-based dry-running detection, SIMOCODE pro monitors the active electrical power consumption of the pump motor and thus the status of the pump – without the need for additional monitoring devices or sensors to be installed. The new technology ensures reliable explosion protection in accordance with ATEX and IECEx criteria and saves costs and time for commissioning and maintenance.

Your benefits through active power-based dry-running protection

Earlier fault detection

- Direct conclusions concerning the flow rate can be drawn from the active power consumption of the pump motor
- Reliable prevention of dry running of the pump and therefore less damage to the pump

Cost and time savings

- No maintenance effort due to the elimination of mechanical wear of the sensors
- No additional sensor required

Reduction of hardware

- No need for additional sensors and mechanical components
- Simplified engineering

Reliable monitoring of the system

- Compliance with ATEX and IECEx criteria
- Reliable and automatic pump shutdown in the event of inadmissible operating conditions

SIMOCODE pro speaks to everyone. Including the Cloud.

With the OPC UA industrial M2M communication protocol, SIMOCODE pro provides an additional communication interface that is independent of the automation system.

Digitalization for more economical operation: SIMOCODE pro with OPC UA

The open and supplier-independent communication via OPC UA guarantees the direct exchange of data with HMI panels or SCADA systems. Motor, process and plant data is therefore available without any losses, wherever it is needed: At the switchboard, but also in the control room for diagnostic purposes. As part of the digital revolution and the efforts to evaluate vast quantities of data even more quickly, all feeder data from SIMOCODE pro can be transmitted by the most direct route to the Cloud using OPC UA.

The data can then be used more intensively and in a targeted fashion – without the need for any intervention in the control.

The result: Plant availability and economy are increased, because you can run analyses, improve energy consumption, or even optimize the entire process.



Benefits

Thanks to OPC UA, SIMOCODE facilitates simple and convenient integration into Cloud-based solutions, e.g. Siemens MindSphere – with so many advantages:

- Data provision in the Cloud for cross-plant, reliable diagnostics
- Convenient and reliable process optimization
- Plant-wide access to control data, process values and readings without complex engineering effort
- Predictive maintenance, energy data management and resource optimization
- Effective protection against manipulation (security)



SIMOCODE ES:
For diagnostics and simple configuration, including in the TIA Portal

SIMOCODE ES provides you with the software for the configuration, startup, operation and diagnosis of SIMOCODE pro. The software is based on the central Totally Integrated Automation Portal (TIA Portal) engineering framework, providing an integrated, efficient and intuitive solution for all automation tasks. SIMOCODE ES offers you a host of advantages, including convenient configuration in the device view, graphical commissioning using drag and drop functions, presentation of signal states online, or clear measurement curves for diagnostic purposes.

The convenient way to optimum process guidance: The integration of SIMOCODE pro into SIMATIC PCS 7

Using standardized blocks and faceplates, SIMOCODE pro can very easily be integrated into the SIMATIC PCS 7 process control system. This makes it extremely easy to integrate service and diagnostic data from the motor management system into higher-level process control systems, for example.

The result: A high level of transparency throughout the plant, enabling faults to be detected at an early stage or prevented from occurring altogether. In general, the greater density of information in the control system enables you to achieve not only greater transparency, but also higher process quality.



Benefits

SIMOCODE pro is your reliable data supplier for maximum process quality. The motor management system offers:

- Data analysis and simulation
- Secure data storage and transmission
- Visualization and recommendation(s)
- Increased availability of components
- Optimization of energy consumption
- Maximization of process efficiency

SIMOCODE pro system overview – General Performance

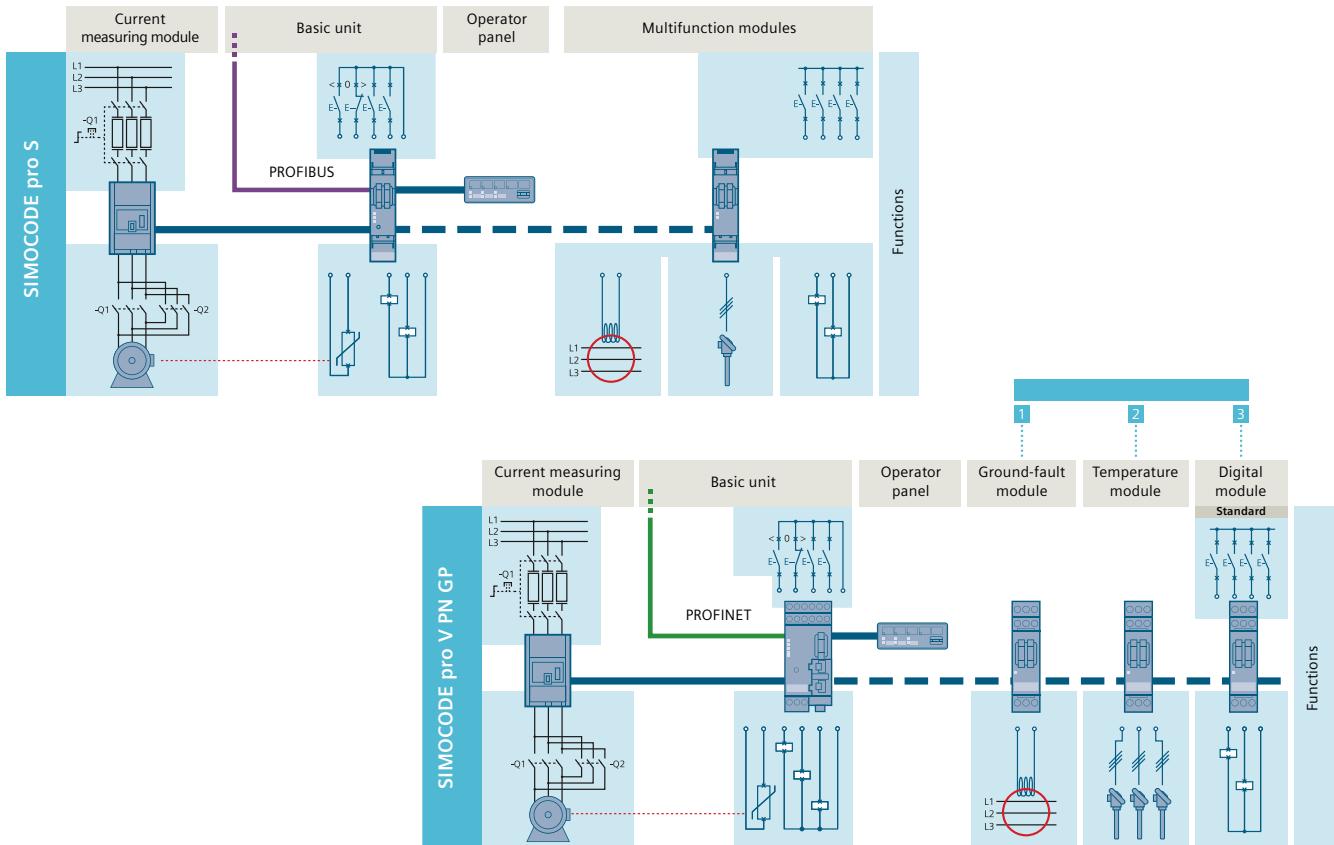

Basic units

SIMOCODE pro S

- 24 V DC
- 110 ... 240 V AC/DC

3UF7020-1AB01-0
3UF7020-1AU01-0

SIMOCODE pro V PN GP

- 24 V DC, 2 ports
- 110 ... 240 V AC/DC, 2 ports
- 24 V DC, 1 port
- 110 ... 240 V AC/DC, 1 port

3UF7011-1AB00-1
3UF7011-1AU00-1
3UF7011-1AB00-2
3UF7011-1AU00-2

Expansion modules

SIMOCODE pro S multifunction modules

Monostable relay outputs,
input voltage

- 24 V DC
- 110 ... 240 V AC/DC

3UF7600-1AB01-0
3UF7600-1AU01-0

Connection cables

3UF793x-0AA00-0 connection cables available in various versions from 0.025 m – 0.5 m

Current measuring modules

Straight-through transformers	0.3 ... 3 A	45 mm	3UF7100-1AA00-0
	2.4 ... 25 A	45 mm	3UF7101-1AA00-0
Busbar connections	10 ... 100 A	55 mm	3UF7102-1AA00-0
	20 ... 200 A	120 mm	3UF7103-1AA00-0
Busbar connections	20 ... 200 A	120 mm	3UF7103-1BA00-0
	63 ... 630 A	145 mm	3UF7104-1BA00-0

Expansion modules

Digital modules

Relay outputs	Input voltage	
	24 V DC	
• Monostable	110 ... 240 V AC/DC	3UF7300-1AB00-0 3UF7300-1AU00-0
Ground-fault module		3UF7510-1AA00-0
Temperature module		3UF7700-1AA00-0

Operator panel

- Titanium gray
- 3UF7200-1AA01-0

SIMOCODE pro system overview – High Performance

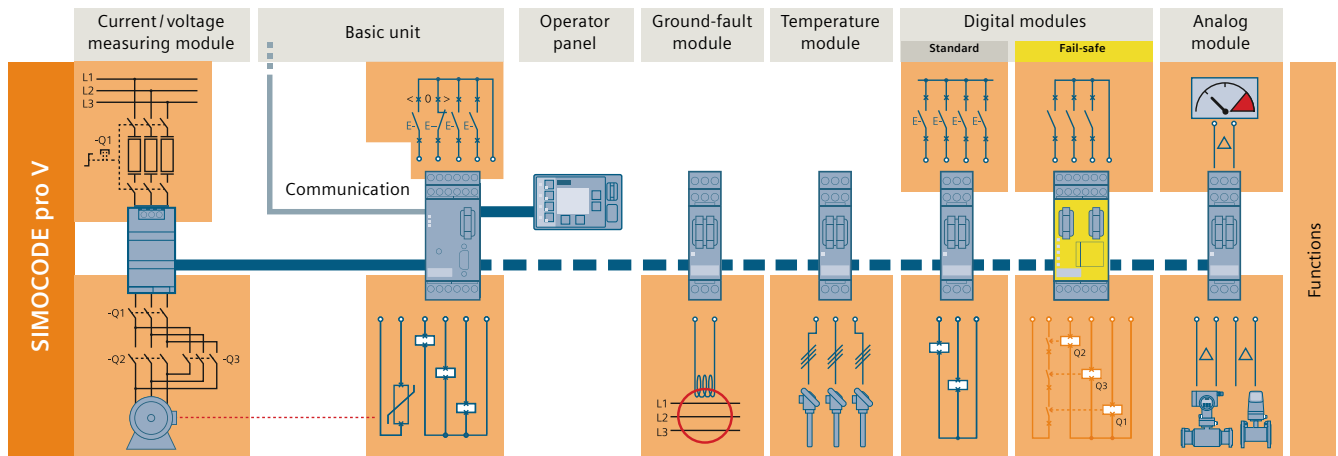

Basic units			
SIMOCODE pro V PROFIBUS			
• 24 V DC			3UF7010-1AB00-0
• 110 ... 240 V AC/DC			3UF7010-1AU00-0
SIMOCODE pro V PROFINET			
• 24 V DC			3UF7011-1AB00-0
• 110 ... 240 V AC/DC			3UF7011-1AU00-0
SIMOCODE pro V Modbus RTU			
• 24 V DC			3UF7012-1AB00-0
• 110 ... 240 V AC/DC			3UF7012-1AU00-0
SIMOCODE pro V EtherNet/IP			
• 24 V DC			3UF7013-1AB00-0
• 110 ... 240 V AC/DC			3UF7013-1AU00-0
Current/voltage measuring modules			
Straight-through transformers	0.3 ... 4 A	45 mm	3UF71□0-1AA01-0
	3 ... 40 A	45 mm	3UF71□1-1AA01-0
	10 ... 115 A	55 mm	3UF71□2-1AA01-0
	20 ... 200 A	120 mm	3UF71□3-1AA01-0
Busbar connection	20 ... 200 A	120 mm	3UF71□3-1BA01-0
	63 ... 630 A	145 mm	3UF71□4-1BA01-0

1 Standard version 2 Dry-running protection

Expansion modules		
Digital modules		
Relay outputs	Input voltage	
• Bistable	24 V DC 110 ... 240 V AC/DC	3UF7310-1AB00-0 3UF7310-1AU00-0
Analog module		3UF7400-1AA00-0

Fail-safe expansion modules	
DM-F Local fail-safe digital module Rated control supply voltage	
• 24 V DC	3UF7320-1AB00-0
• 110 ... 240 V AC/DC	3UF7320-1AU00-0
DM-F PROFIsafe fail-safe digital module ¹⁾ Rated control supply voltage	
• 24 V DC	3UF7330-1AB00-0
• 110 ... 240 V AC/DC	3UF7330-1AU00-0
¹⁾ Possible with SIMOCODE pro V PROFIBUS / PROFINET basic unit	

Operator panels with display	
Languages: English / German / French / Spanish / Portuguese / Italian / Polish / Finnish	3UF7210-1AA01-0
Languages: English / Chinese / Russian / Korean	3UF7210-1BA01-0

Software

SIMOCODE ES (TIA Portal) V15 Basic

Basic functional scope including Premium Trial License	3ZS1322-6CE13-0YG8
--	--------------------

SIMOCODE ES (TIA Portal) V15 Standard

Floating license for one user <ul style="list-style-type: none">License key on USB flash drive, Class ALicense key and software download, Class A	3ZS1322-5CC13-0YA5 3ZS1322-5CE13-0YB5
Upgrade for SIMOCODE ES 2007 Standard	3ZS1322-5CC13-0YE5
Software Update Service	3ZS1322-5CC00-0YL5

SIMOCODE ES (TIA Portal) V15 Premium

Floating license for one user <ul style="list-style-type: none">License key on USB flash drive, Class ALicense key and software download, Class A	3ZS1322-6CC13-0YA5 3ZS1322-6CE13-0YB5
Upgrade for SIMOCODE ES 2007 Premium	3ZS1322-6CC13-0YE5
Software Update Service	3ZS1322-6CC00-0YL5

SIMOCODE pro block library for SIMATIC PCS 7 Version V9 with Advanced Process Library (APL)

Engineering software V9	3ZS1632-1XX03-0YA0
Runtime license V9	3ZS1632-2XX03-0YB0
Upgrade for PCS 7 block library SIMOCODE pro V8	3ZS1632-1XX03-0YE0

SIMOCODE pro block library for SIMATIC PCS 7 Version V8 with Advanced Process Library (APL)

Engineering software V8	3ZS1632-1XX02-0YA0
Runtime license V8	3ZS1632-2XX02-0YB0

SIMOCODE pro block library for SIMATIC PCS 7 Version V7 without Advanced Process Library (APL)

Engineering software V7	3UF7982-0AA10-0
Runtime license V7	3UF7982-0AA11-0
Engineering software for V7–V9 migration	3UF7982-0AA20-0

Published by
Siemens AG 2018

Digital Factory
Control Products
P.O. Box 23 55
90713 Fürth
Germany

Article No. DFCP-B10220-00-7600
Printed in Germany
Dispo 27601
HL 17012670 WS 11182.

Subject to changes and errors. The information given in this document only contains general descriptions and/or performance features which may not always specifically reflect those described, or which may undergo modification in the course of further development of the products.

The requested performance features are binding only when they are expressly agreed upon in the concluded contract

SIMOCODE is a registered trademark of Siemens AG. Any unauthorized use is prohibited. All other designations in this document may represent trademarks whose use by third parties for their own purposes may violate the proprietary rights of the owner.